



# **SNOW PLOW SET UP AND INSTALLATION INSTRUCTIONS**

**28 SERIES SNOW PLOW**  
**FOR PLOW SERIAL NUMBERS AFTER**  
**28D101329**

# TABLE OF CONTENTS

	Page
INTRODUCTION .....	2
TOOL LIST .....	2
SAFETY .....	3
INSTALLATION INSTRUCTIONS .....	4
General .....	4
Electrical Installation .....	4
Mechanical Installation.....	7
Disk Shoe Assembly.....	7
Wing Assembly .....	8
Mounting Snow Plow To Vehicle.....	10
Installing The Cylinder Lock Clamp .....	12
Operation Check and Inspection.....	13
Disk Shoe Adjustment.....	13
Trip Spring Adjustment .....	15
Float Limiter Adjustment .....	15
HYDRAULIC SCHEMATIC.....	16
WIRING SCHEMATICS	
WIRING SCHEMATIC .....	18
W1 Wire Harness - Vehicle .....	19
W2 Wire Harness - Control Box "B" .....	19
W3 Wire Harness - Control Box "A" .....	20
W4 Wire Harness - Vehicle End Control .....	20
W5 Wire Harness - Vehicle End .....	21
W6 Wire Harness - Pump End Control.....	21
W7 Wire Harness - Pump End Main .....	22
W9 Wire Harness - Battery Power .....	23
W8 Wire Harness (No Longer Used) .....	23
W10 Wire Harness - Battery Ground.....	23
W11 Wire Harness - Solenoid Switch Power .....	23
W12 Wire Harness - Jackstand Switch Jumper .....	24
W13 Wire Harness - Jackstand Switch Jumper .....	24
W14 Wire Harness - Control Box Jumper (2 Req.).....	24
TORQUE SPECIFICATIONS.....	25
PRE-DELIVERY & DELIVERY CHECKLIST .....	Outside Back Cover

# INTRODUCTION

This manual was written for the assembly, installation and set up of your new Sno-Way Plow. Most importantly, this manual provides an operating plan for safe use. Refer to the Table of Contents for an outline of this manual.

Please keep this manual with your machine at all times as reference material and so it can be passed on to the next owner if the machine is sold.

We require that you read and understand the contents of this manual COMPLETELY, especially the chapter on SAFETY, before attempting any procedure contained in this manual.



The Society of Automotive Engineers has adopted this SAFETY ALERT SYMBOL to pinpoint characteristics that, if NOT carefully followed, can create a safety hazard. When you see this symbol in this manual or on the machine itself, BE ALERT!, your personal safety and the safety of others, is involved.

- Defined in the next column, are the SAFETY ALERT messages and how they will appear in this manual.



## WARNING

**FAILURE TO HEED CAN RESULT IN SERIOUS INJURY OR DEATH.**



## CAUTION

**Information, that if not carefully followed, can cause minor injury or damage to equipment!**

*NOTE: Additional information concerning the equipment or the procedure that may or may not be contained elsewhere in this manual.*

**BE AWARE!** It is illegal to remove, deface or otherwise alter the safety decals mounted on this equipment.

We reserve the right to make changes or improve the design or construction of any part(s) without incurring the obligation to install such parts or make any changes on any unit previously delivered.

**REMEMBER** after the Snow Plow is installed on the vehicle, the Pre-Delivery Check List and Delivery Check List (on the outside back cover of this manual) must be completed

## TOOL LIST

Safety Goggles

Wrenches 3/8" - 15/16"

Impact Wrench

Wire Crimp Tool

Torque Wrench 0-300 inch lbs.

Utility knife

Drill Bit 9/32"

12 Volt Test Light

Impact Sockets 3/8" - 15/16"

6" C-Clamps

Drill

Hole Saw 1 3/8"

Rubbing Alcohol

Clean, Dry Cloth



## SAFETY



**BEFORE ATTEMPTING ANY PROCEDURE IN THIS BOOK, READ AND UNDERSTAND ALL THE SAFETY INFORMATION CONTAINED IN THIS SECTION. IN ADDITION, ENSURE ALL INDIVIDUALS WORKING WITH YOU ARE ALSO FAMILIAR WITH THESE SAFETY PRECAUTIONS.**

**For your safety Warning and Information Decals have been placed on this product to remind the operator to take safety precautions. It is important that these decals are in place and are legible before operation begins. New decals can be obtained from Sno-Way or your local dealer.**

**REMEMBER** The careful operator is the best operator. Most accidents are caused by human error. Certain precautions must be observed to prevent the possibility of injury to operator or bystanders and/or damage to equipment.

**NEVER** operate Plow when under the influence of alcohol, drugs or other medications that could hamper your judgement and reactions. An accident may result in serious injury or death to other persons or yourself.

**ALWAYS** operate vehicle in a well-ventilated area. The carbon monoxide in exhaust gas is highly toxic and can cause serious injury or death.

**NEVER** allow hands, hair or clothing to get near any moving parts such as fan blades, belts and pulleys. Never wear neckties or loose clothing when working on the vehicle.

**NEVER** wear wrist watches, rings or other jewelry when working on the vehicle or individual equipment. These things can catch on moving parts or cause an electrical short circuit that could result in serious personal injury.

**ALWAYS** wear safety goggles when working on the vehicle to protect your eyes from battery acid, gasoline, and dust or dirt from flying off of moving engine parts.

**ALWAYS** be aware of and avoid contact with hot surfaces such as engine, radiator, and hoses.

**ALWAYS** wear safety glasses with side shields when striking metal against metal! In addition, it is recommended that a softer (non-chipable) metal material be used to cushion the blow. Failure to heed could result in serious injury to the eye(s) or other parts of the body.

**NEVER** allow children or unauthorized person to operate this unit.

**NEVER** exceed 45 m.p.h. when snow plow is attached to vehicle. Braking distances may be reduced and handling characteristics may be impaired at speeds above 45 m.p.h.

**ALWAYS** lock the vehicle when unattended to prevent unauthorized operation of the plow.

**ALWAYS** check the job site for terrain hazards, obstructions and people.

**NEVER** exceed 10 m.p.h. when plowing. Excessive speed may cause serious injury and damage of equipment and property if an unseen obstacle is encountered while plowing.

**ALWAYS** position blade so it does not block path of headlamps beam. Do not change blade positions while traveling. An incorrect plow position blocking headlamp beam may result in an accident.

**ALWAYS** check surrounding area for hazardous obstacles before operating this unit.

**ALWAYS** inspect the unit periodically for defects. Parts that are broken, missing or plainly worn must be replaced immediately. The unit, or any part of it should not be altered without prior written approval of the manufacturer.

**ALWAYS** insert the cylinder lock when plow is not in use. If the cylinder lock is not installed, the plow blade could inadvertently drop and cause serious injury.

**ALWAYS** shut off the vehicle engine, place the transmission in Neutral or Park, turn the ignition switch to the "OFF" position and firmly apply the parking brake of the vehicle before attaching or detaching the blade from the vehicle or when making adjustments to the blade.

**ALWAYS** inspect lift system bolts and pins whenever attaching or detaching the plow, and before traveling. Worn or damaged components could result in the plow dropping to the pavement while driving, causing an accident.

**ALWAYS** keep hands and feet clear of blade and A-Frame when attaching or detaching plow.

**NEVER** place fingers in A-frame or mount lug holes to check alignment when attaching snow plow. Sudden motion of the plow could severely injure a finger.

**NEVER** stand between the vehicle and blade or directly in front of blade when it is being raised, lowered or angled. Clearance between vehicle and blade decreases as blade is operated and serious injury or death can result from blade striking a body or dropping on hands or feet.

**NEVER** work on the vehicle without having a fully serviced fire extinguisher available. A 5 lb or larger CO<sup>2</sup> or dry chemical unit specified for gasoline, chemical or electrical fires, is recommended.

**NEVER** smoke while working on the vehicle. Gasoline and battery acid vapors are extremely flammable and explosive.

**NEVER** use your hands to search for hydraulic fluid leaks; escaping fluid under pressure can be invisible and can penetrate the skin and cause a serious injury! If any fluid is injected into the skin, see a doctor at once! Injected fluid **MUST BE** surgically removed by a doctor familiar with this type of injury or gangrene may result.

**REMEMBER** it is the owner's responsibility for communicating information on the safe use and proper maintenance of this machine.

# INSTALLATION INSTRUCTIONS

## General

Install the Sub-Frame on the vehicle using the instructions supplied with the Sub-Frame package.

**IMPORTANT:** The Lobo™ Snow Plow Shipping Package includes a Heavy-Duty Nosepiece (#96102896) which **MUST** be used with the 28 Series Snowplow. This Nosepiece installs with the Sub-Frame the same as a standard nosepiece and General Installation instructions with the Sub-Frame will cover installation of the Heavy-Duty Nosepiece. Disregard information in the Sub-Frame Manual regarding the Sub-Frame Part Number.



## WARNING

### VEHICLES EQUIPPED WITH AIR BAGS!

Certain Vehicles equipped with Air Bags cannot be equipped with Snow Plows because of the possibility of the Air Bag being deployed if the Snow Plow hits an obstruction. Before attempting to install a Snow Plow on a vehicle equipped with Air Bags, consult with the vehicle manufacturer to be sure that Snow Plow operation will not result in inadvertent deployment of the vehicle air bag.

**FAILURE TO HEED CAN RESULT IN SERIOUS INJURY OR DEATH.**

## Electrical Installation



## WARNING

Ensure Engine is OFF and set parking brake before mounting equipment on to vehicle. Vehicle movement, equipment failure or inadvertent operation of the control switches during installation could result in serious injury.

**FAILURE TO HEED CAN RESULT IN SERIOUS INJURY OR DEATH.**

1. Park vehicle in a flat clear safe work area. Set park brake. Remove key from ignition switch.

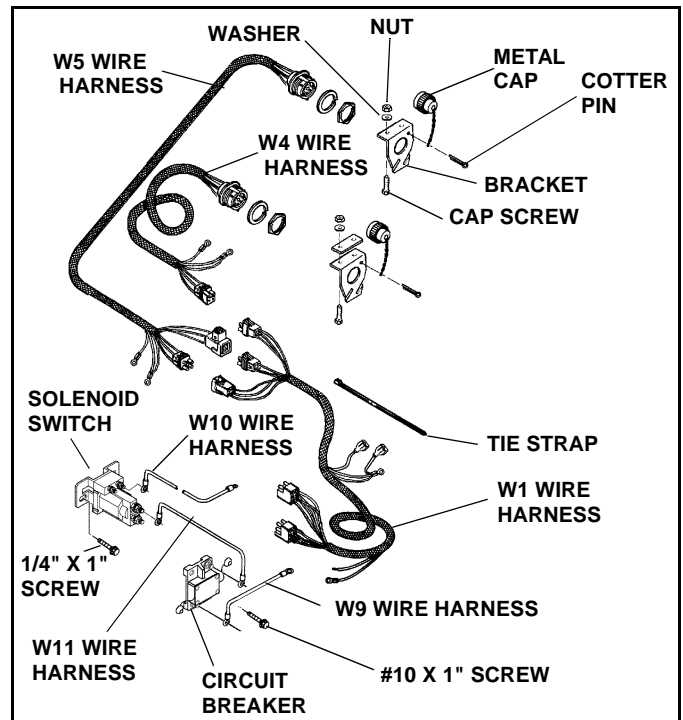

Figure 1-1

2. Remove the Wiring Harness from the carton and locate the following parts (See Figure 1-1):

- W1 Wire Harness - Vehicle (#96103237), 1 req.
- W4 Wire Harness - Vehicle End Control (#96103236), 1 req.
- W5 Wire Harness - Vehicle End (#96100097), 1 req.
- W9 Wire Harness, - Battery Power (#96102891), 1 req.
- W10 Wire Harness, - Battery Ground(#96002100), 1 req.
- W11 Wire Harness, - Solenoid Switch Power (#96102891), 1 req.
- Mounting Bracket, (#96002130), 2 req.
- Circuit Breaker (#96101210), 1req.
- Start Solenoid Switch (#96002086), 1req.
- Self Tapping Screws, 1/4" x 1" (#98009092), 2 req.
- Self Tapping Screws, #10 x 1" (#98100037), 2 req.
- Nut, Hex (#98009033), 1/4" 4 req.
- Washer, Lock (#98009031), 1/4" 4 req.
- Cap Screw, Hex (#98009027), 1/4" x 1" 4 req.
- Metal Cap (#96002107), 2 req.
- Pin, Cotter, 3/16" x 1" (#98009233), 2 req.

*NOTE: Take the extra time needed to plan the routing of the Wiring Harness before drilling any holes or fastening the Harness, Circuit Breaker or Solenoid Switch in place. Read all the instructions carefully to ensure all the required conditions are met for a safe and professional installation.*

**NOTE:** On some vehicles, especially some vehicles with the battery located on the passenger side of the engine compartment, the standard underhood wiring harness may be somewhat short. If additional harness length is desirable to properly route the underhood harness, a 3 foot harness extensions (#96103886) is available as a service part.

3. Determine a convenient location for the Mounting Brackets (#96002130) that will satisfy the following conditions;

- A flat, smooth mounting surface at least the size of the bracket mounting surface.
- Allows the Wiring Harness to extend at least 3" from behind the bracket before making any bends. (See Figure 1-2)

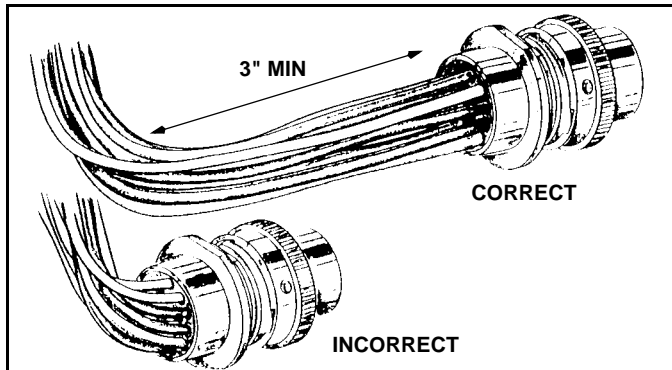

**Figure 1-2**

- Make sure there is enough slack in the plow Wiring Harnesses to insure that Harness will not pull when plow moves to full up or down positions.
- Brackets should be located on the same side of the vehicle (left or right) as the battery.
- Make sure that Bracket is located so that Plow Harness will not rub or get pinched between nose piece and A-Frame when plow is raised or lowered.



## CAUTION

**Always follow solvent manufacturer's precautionary warnings and handling procedures when using solvents.**

4. Scrub the mounting surface with a mild abrasive pad soaked in a solution of 50/50 Isopropyl Alcohol (rubbing alcohol) and water or heptane. Wipe the surface dry with a clean, dry cloth to remove the solvent and contaminants.

5. Peel the protective backing from the adhesive strip on the Mounting Bracket and carefully position the bracket on the mounting surface. Clamp the bracket in place with C-Clamps and allow it to stay clamped for at least 20 minutes. For permanent mounting, drill two (2) 9/32" holes into the mounting surface using the holes in the bracket as a template, and secure with two (2) 1/4" bolts and nuts. (See Figure 1-3)

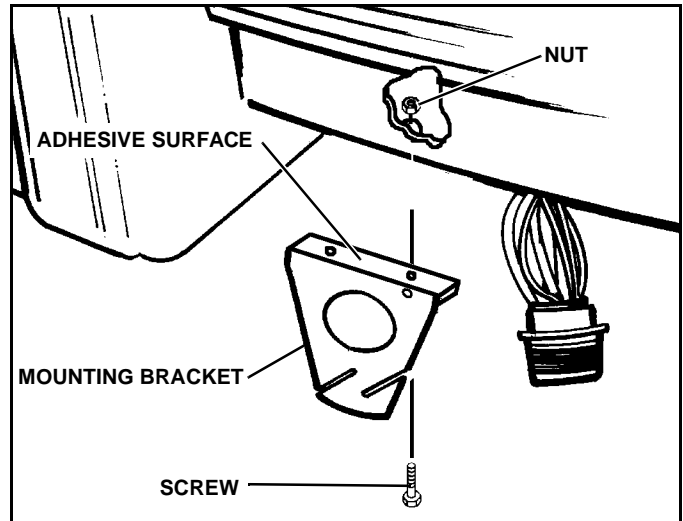

**Figure 1-3**

**IMPORTANT:** The Circuit Breaker and Start Solenoid Switch must be placed in a location that will avoid excessive heat. **DO NOT** locate these parts near the engine exhaust manifold. A preferred location is one that will receive good air flow from the radiator fan but protected from excessive engine heat.

6. Locate a place to mount the Solenoid Switch and Circuit Breaker where they can be firmly attached using the Mounting Screws provided. The Solenoid Switch should be within 18 inches of the battery negative post and the Circuit Breaker should be within 18 inches of the battery positive post and the Solenoid Switch.

7. Mount the Solenoid Switch with two (2) 1/4" x 1" Self-Tapping Screws.

8. Mount the circuit breaker with two (2) #10 x 1" Self-Tapping Screws.

9. Attach the Small Ring Terminal of the Solenoid Ground Wire to one of the Small Terminals of the Start Solenoid Switch. (See Figure 1-4)



## WARNING

**Disconnect vehicle NEG. (-) battery cable while performing Steps 10-16 to avoid serious bodily injury from fire or explosion.**

**FAILURE TO HEED CAN RESULT IN SERIOUS INJURY OR DEATH.**

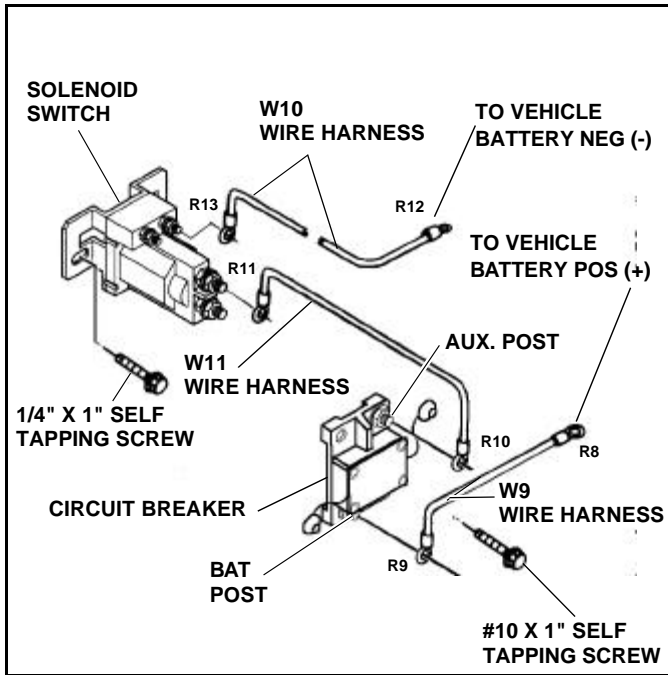

Figure 1-4

10. From W9 Wire Harness attach:

- Terminal R9 to the Bat. Post of the Circuit Breaker.
- Terminal R8 to the positive (+) side of the vehicle battery. (See Figure 1-7)

11. From W10 Wire Harness attach:

- Terminal R13 to the NEG. (-) terminal of the Solenoid Switch. (See Figure 1-4)
- Terminal R12 to the negative (-) side of the vehicle battery. (See Figure 1-7)

12. From W11 Wire Harness attach:

- Terminal R10 to the AUX terminal of the Circuit Breaker. (See Figure 1-4)
- Terminal R11 to one of the larger terminals on the Solenoid Switch. (See Figure 1-4)

13. From W1 Wire Harness attach:

- R1 Terminal (14Gr, 13Tan, 10Brn Wires) to the POS. (+) terminal on the Solenoid Switch.

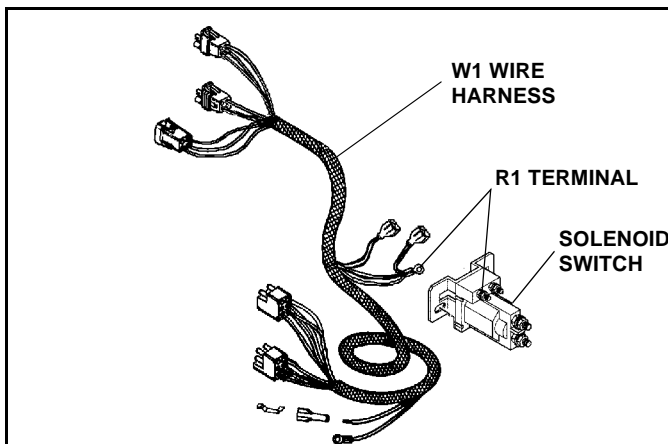

Figure 1-5

14. From the W5 Wire Harness attach:

- R4 Terminal to the second large terminal on the Solenoid Switch. (See Figure 1-6)
- R5 Terminal to the negative (-) side of the vehicle battery (See Figure 1-7)
- C5 Connector to W1 Wire Harness C5 Connector
- C4 Connector to W1 Wire Harness C4 Connector

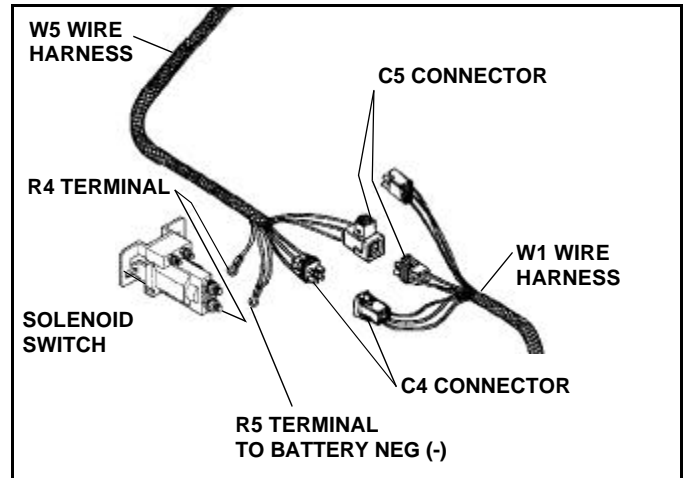

Figure 1-6

*NOTE: If the vehicle has a "side post" battery, it is recommended that adaptors be purchased to make connections at the vehicle battery easier. (See Figure 1-7) Adaptors can be purchased locally or are available from your Sno-Way Dealer, Part #96100773.*

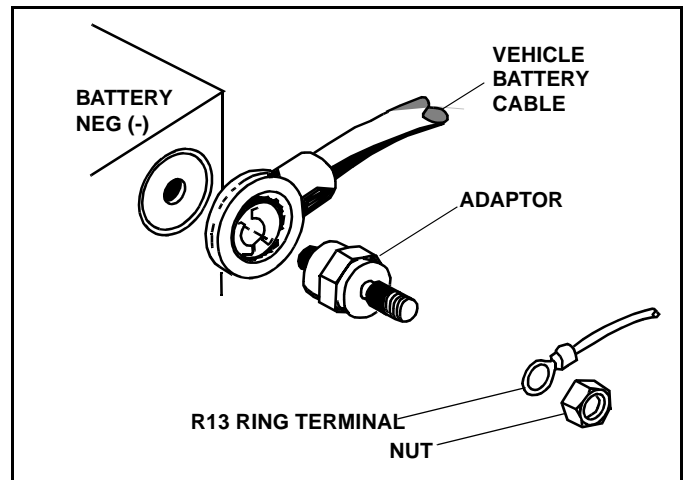

Figure 1-7

15. From the W4 Wire Harness attach:

- R14 Terminal to the negative (-) side of the vehicle battery. (See Figure 1-7) and (See Figure 1-8)
- R3 Terminal to the second large terminal on the Solenoid Switch, same terminal as R4 Terminal of W5 Wire Harness. (See Figure 1-6) and (See Figure 1-8)
- C1 Connector to W1 Wire Harness C1 Connector (See Figure 1-8)

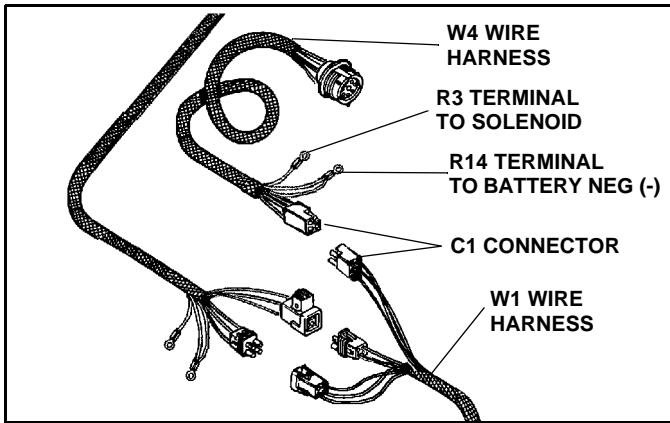

Figure 1-8

**IMPORTANT:** After all wiring connectors have been made to the vehicle battery spray the battery terminals and connections with battery terminal protectant.

16. Fasten each Wiring Harness with a tie strap behind the plug as shown in Figure 1-6 so that the Wiring Harness does not make any bend for at least 3" from the plug end.

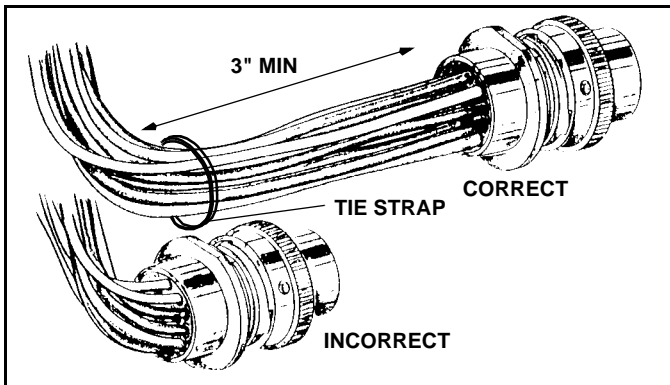

Figure 1-9

17. Mount each plug in the mounting bracket from the vehicle back side. Position the plug with the milled end to the top. Place the washer over the end of the plug and secure with the large nut. (See Figure 1-10)

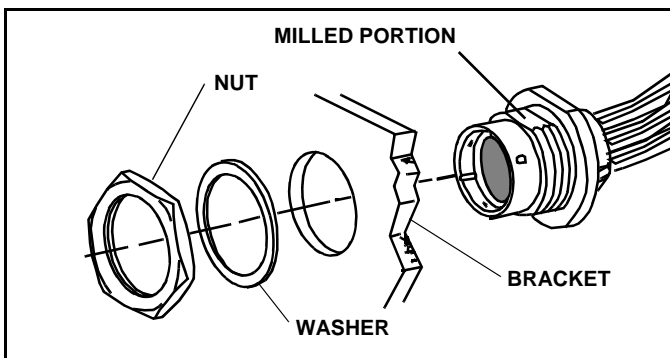

Figure 1-10

*NOTE: If the mounting plug bracket is on the left (drivers) side of the vehicle, position the plug so that the milled portion is facing down, this will allow the Harness to face inward or toward the plow.*

18. Attach each protective Metal Cap to the Mounting Bracket by spreading the Cotter Pin, placing one side of the pin through the end of the chain, closing the pin, inserting it through the small hole in the Bracket and spreading both ends of the Cotter Pin. (See Figure 1-11)

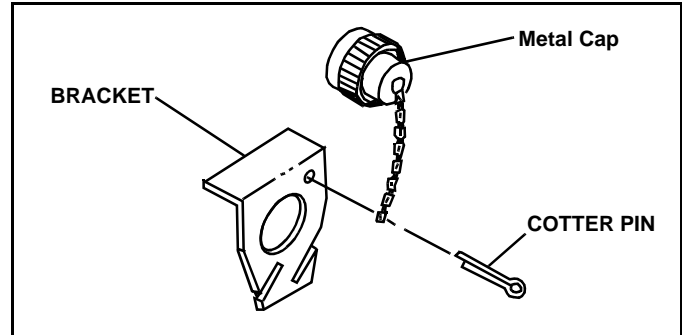

Figure 1-11

*NOTE: If desired, the Metal Cap may be kept in the vehicle when not in use rather than attached to the Plug Mounting Brackets. If kept in the vehicle when not in use remember that the Metal Caps must be installed over the plugs when the Harnesses are disconnected to prevent corrosion of the electrical contacts.*

19. Attach the Harness assembly to the vehicle at different points in the cab and engine compartment that will not allow the Harness to come in contact with sharp edges, hot components and moving parts or mechanisms.

*NOTE: To complete vehicle wiring and controller installation see Assembly & Installation Instructions for particular Controller ordered with Plow.*

## Mechanical Installation

### Disk Shoe Assembly

1. Remove the Disk Shoe Mounting Brackets, hardware, and Disk Shoe Assemblies from the Power Pack Shipping Carton.

2. Locate Wings so the lower rails are accessible (lay flat with concave blade surface down).



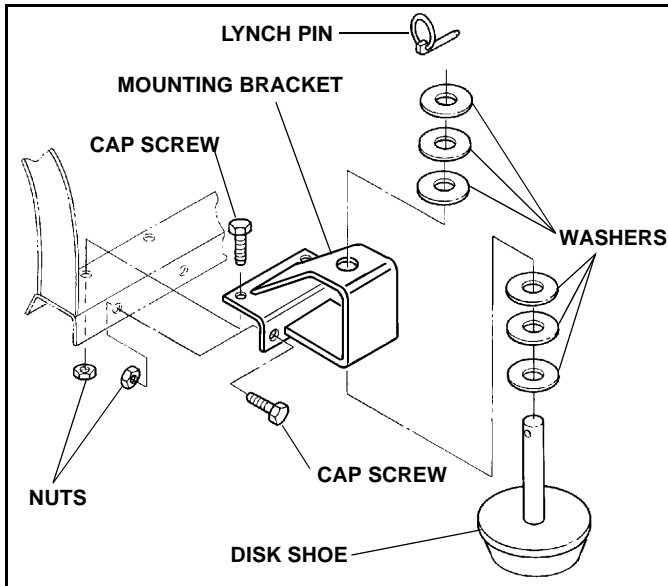

**Figure 1-12**

3. Install the two Disk Shoe Mounting Brackets (#96101401) onto the lower rail of the Blade Assembly utilizing four (4) holes in the Lower Rail near outer end of each rail and secure with four (4) 3/8" x 1-1/4" Cap Screws (#98009034) and Nylock Nuts (#98009009) through each Bracket and Blade Lower Rail. Torque to 35 lb. ft. (See Figure 1-12)

4. Remove the Lynch Pin from each Disk Shoe Assembly and as many Flat Washers as required to provide desired Disk Shoe position. Install stem of Disk Shoe upward from bottom of Disk Shoe Bracket and then install any previously removed Flat Washers and the Lynch Pin to the top of the Disk Shoe Stem.

*NOTE: Final Disk Shoe height adjustment must be made after the plow is mounted on the vehicle (See "Disk Shoe Adjustment" on page 13).*

### Wing Assembly

1. Remove the Center Blade Assembly from shipping container.

2. Remove the Cap Screws from the Hold Down Plates at the top of each of the two Wing Pivot Shafts and then remove the pivot shafts from the Center Blade Assembly. (See Figure 1-13)

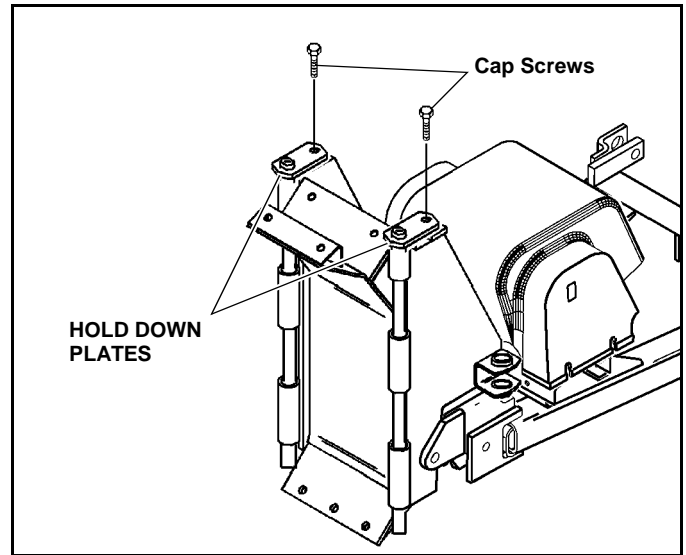

**Figure 1-13**

3. Swing the Wing Cylinders out to the side so they will be out of the way for installing the Wings. (See Figure 1-14)

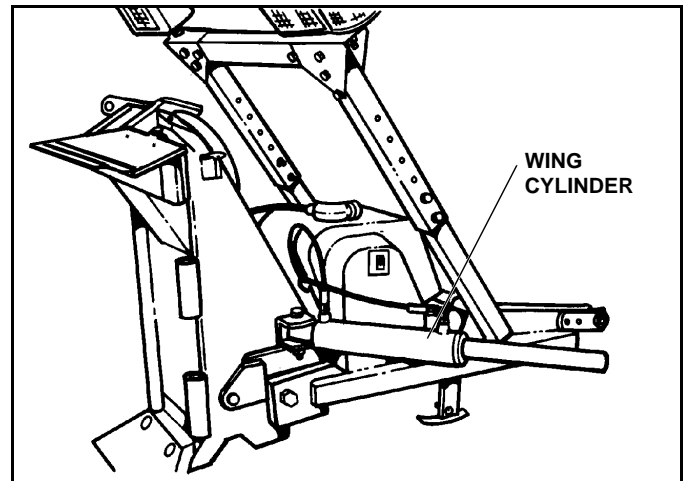

**Figure 1-14**



## CAUTION

**Wings weigh 125 lbs. Use proper lifting device and methods to lift and support wings during installation.**

4. Place the Right Wing next to the right side of the Center Blade Assembly and position it so that the Hinge Tubes on the Center Blade assembly and the Hinge Tubes on the Wing Assembly are lined up. Insert one Wing Pivot Shaft down through the Hinge Tubes on the Center Blade and Wing Assemblies.



## WARNING

Once Wing Pivot Shafts are installed Wings are free to rotate and may create pinch points between wings and Center Blade Assembly or floor. Remember, Wings are heavy and will be hard to stop once they start moving.

**FAILURE TO HEED CAN RESULT IN SERIOUS INJURY OR DEATH.**

*NOTE: Oiling the Pivot Shaft and Pivot Tubes will aid in shaft installation.*

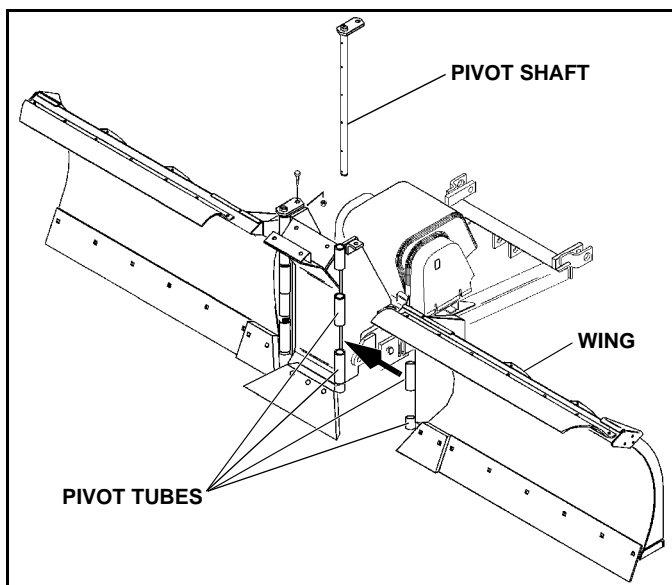

**Figure 1-15**

5. Repeat this procedure for the Left Wing Assembly.

6. Line up the hole in the Pivot Shaft Hold Down Plates and the Retainer Brackets on the Center Wing Assembly. Do Not re-install the Cap Screws and Nuts at this time. This Hardware will be re-installed after the Center Deflector is installed.

7. Lubricate Both Pivot Shafts with a good quality EP Lithium base grease.

*NOTE: For extremely cold weather plowing, continuous sub Zero operation, an alternative is to remove the grease fittings and fill the grease cavity with SAE 140 Gear Oil, and then replace the grease fitting.*

8. Remove the 5/8" x 4" Cap Screw and Locknut from the rod end of the two Wing Cylinders. Swing the rod end of the cylinders towards the Wings until the hole in the rod end of the cylinder lines up with the holes in the cylinder mounting brackets on each Wing. Secure with Cap Screw removed earlier and Torque to 25-30 Lb-ft.

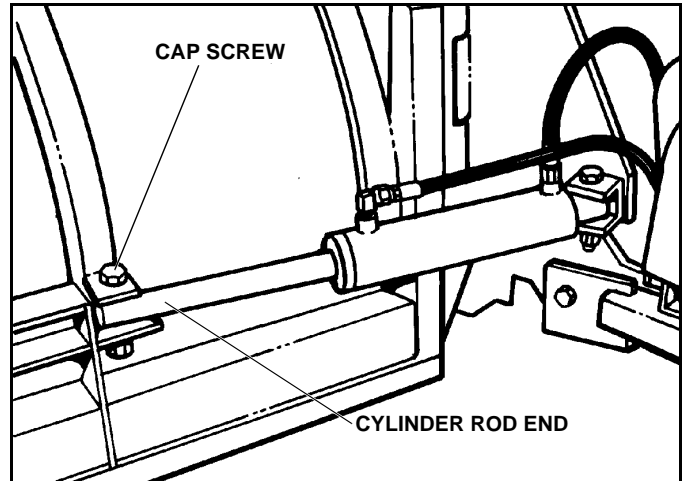

**Figure 1-16**

9. Center Deflector mounting holes on top of plow blade.

*NOTE: Install Deflectors with beveled end of Deflector at outer end of plow wing.*

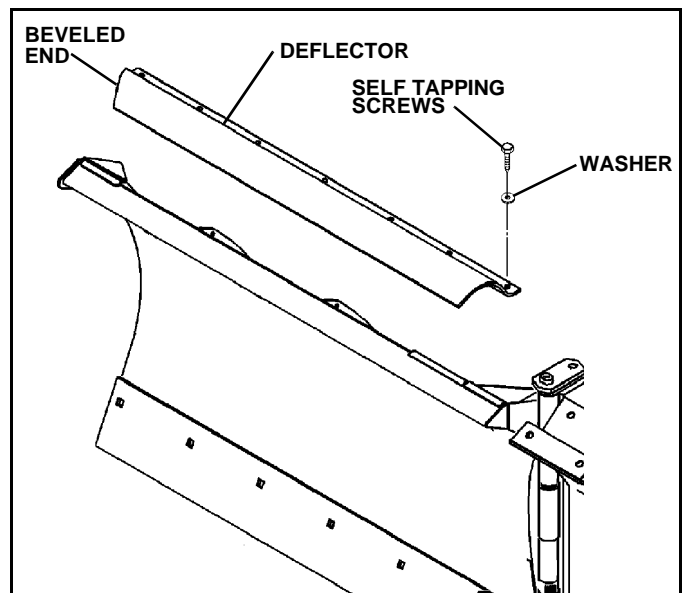

**Figure 1-17**

10. Use holes in Deflector as template to center punch and drill 9/32" holes for Self Tapping Screws.

*NOTE: It is recommended that LOCTITE® or similar thread lock be used on these Self Tapping Screws.*

11. Install 5/16" X 1" Self Tapping Screws (#98019176) and Flat Washers in every hole in Deflector. Do not tighten until all screws are installed.

12. After all screws are installed, torque to 15 lb.-ft.

13. Remove the two (2) 5/16 x2" Cap Screws, Flat Washers, and the two (2) Spacers (#96102938) from the Deflector Mounting Bracket on the top of the Center Blade Assembly. Install the Center Deflector (shipped

loose in the Power Pack Carton) using the two (2) Spacers, 5/16x2" Cap Screws and Flat Washers removed earlier. Torque to 15 lb.-ft.

14. Install the 1/2" Cap Screws and Nylock Nuts, removed in step #2, into the holes in the Pivot Shaft Hold Down Plates and the Retainer Brackets on the Center Wing Assembly with a flat washer on top of the Center Deflector, and torque the Nylock Nut to 25-30 lb.-ft.

15. If lighting system and light bar are used, install light wiring in the vehicle and install the light bar and lights at this time using the instructions included in the light and light mounting package.

16. Install Blade Guides (blade side markers) to holes in outside blade ribs, secure using hardware supplied with Blade Guide Kit. (See Figure 1-18)

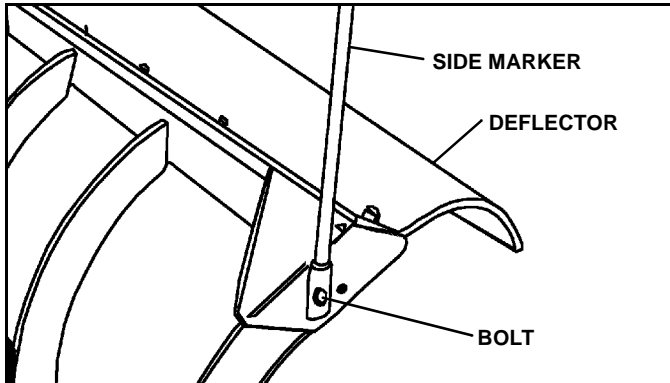

Figure 1-18

17. If the Snow Plow is in a location where it will not have to be moved before mounting on the vehicle, pull the Transport Storage Pin on the Jackstand Assembly and let the stand swing down. Lift the rear of the plow A-Frame assembly high enough to allow the Jackstand to swing down until the base (foot) of the Jackstand is flat on the ground.

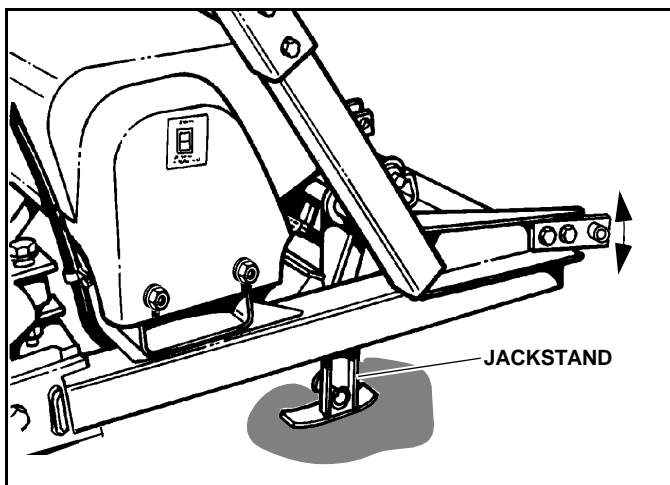

Figure 1-19

## Mounting Snow Plow To Vehicle



**WARNING**

### VEHICLES EQUIPPED WITH AIR BAGS!

**Certain Vehicles equipped with Air Bags cannot be equipped with Snow Plows because of the possibility of the Air Bag being deployed if the Snow Plow hits an obstruction. Before attempting to install a Snow Plow on a vehicle equipped with Air Bags, consult with the vehicle manufacturer to be sure that Snow Plow operation will not result in inadvertent deployment of the vehicle air bag.**

**FAILURE TO HEED CAN RESULT IN SERIOUS INJURY OR DEATH.**

1. Move the vehicle to the Snow Plow and position it so that the mounting points at the rear of the A-Frame are within 3-4 inches of the lower mounting points of the Subframe on the vehicle (It is much easier to move the vehicle instead of the plow).



**WARNING**

**Be sure all plow functions are OFF on ALL plow controls in the vehicle cab and the Raise/Lower Rocker Switch on the Pump Cover is in the OFF position before making ANY electrical connections.**

**FAILURE TO HEED CAN RESULT IN SERIOUS INJURY OR DEATH.**



**WARNING**

- Ensure Engine is OFF and set parking brake before mounting Snow Plow to vehicle, vehicle movement, equipment failure or inadvertent operation of the control switches during installation could result in serious injury.

- NEVER place fingers in A-Frame or mount lug holes to check alignment. Sudden motion of the Plow could severely injure a finger.

**FAILURE TO HEED CAN RESULT IN SERIOUS INJURY OR DEATH.**

2. Remove the protective Plastic Covers from the Snow Plow Wiring Harnesses and store them inside the vehicle for installation when the plow is removed.

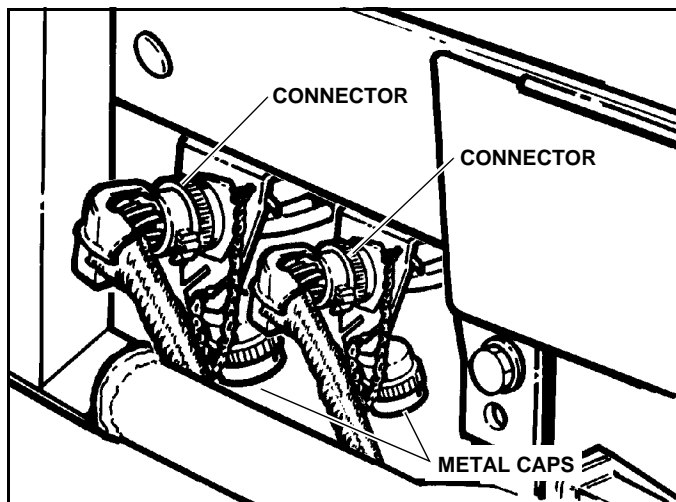

Figure 1-20

3. Remove the Metal Caps from the vehicle end of the Wiring Harnesses by rotating them counterclockwise and store them as shown in Figure 1-20, if Metal Caps are chained to the Harness Plug Bracket. If Metal Caps are not chained to the brackets store the Metal Caps in the vehicle for future use.



## CAUTION

**Information, that if not carefully followed, can cause minor injury or damage to equipment!**

4. Align the two Harness Connector halves, push the plow end Connector onto the vehicle Connector and rotate clockwise to lock. Connect all electrical connections between the Snow Plow and the vehicle, except for Light Harness, if the Snow Plow is equipped with lights.

5. Turn vehicle ignition switch to the accessory position.

6. Place the Up/down Switch on the Plow Controller, in the cab of the vehicle, in the down position and also activate the Down Pressure Switch on the Plow Controller.



## WARNING

When using the raise/lower Rocker Switch on the Pump Cover to raise or lower the Plow A-Frame be especially careful of the movement of the light bar, if equipped, which occurs during raising and lowering of the A-Frame on the Jackstand.

**FAILURE TO HEED CAN RESULT IN SERIOUS INJURY OR DEATH.**

7. Raise the rear of the A-Frame (using the Rocker Switch on the pump cover) to ensure that the A-Frame is higher than the Subframe mounting points. (See Figure 1-21) The plow can then be manually moved into position for connecting the lower Hitch Pins. Move the plow manually by grasping one end of the blade and moving one side and then the other side. Again, if the plow is more than 3-4 inches from proper alignment, move the vehicle - it's easier. But remember to disconnect the electrical connections BEFORE backing away from the plow to avoid stretching and damaging the electrical Wiring Harness.



## CAUTION

**NEVER use pliers or any other tool to force the Connector halves together.**

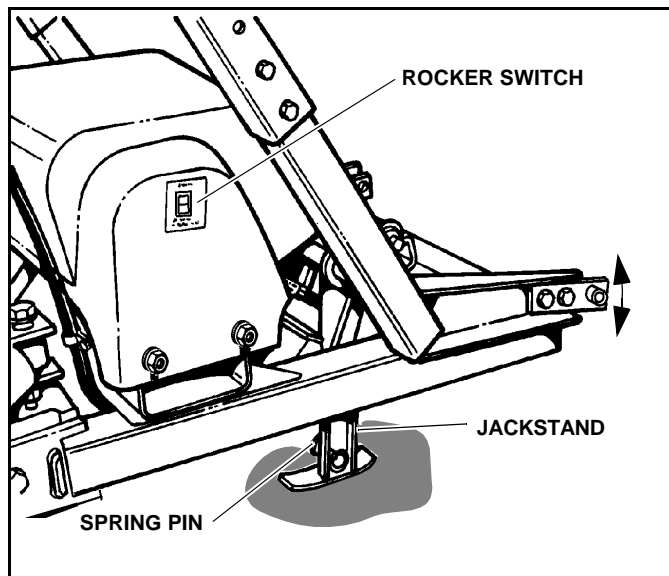

Figure 1-21

8. Lower the A-Frame into alignment with the lower Hitch Pin mounting holes of the vehicle Subframe and install the two lower Hitch Pins. Secure with Lynch Pins. (See Figure 1-22)

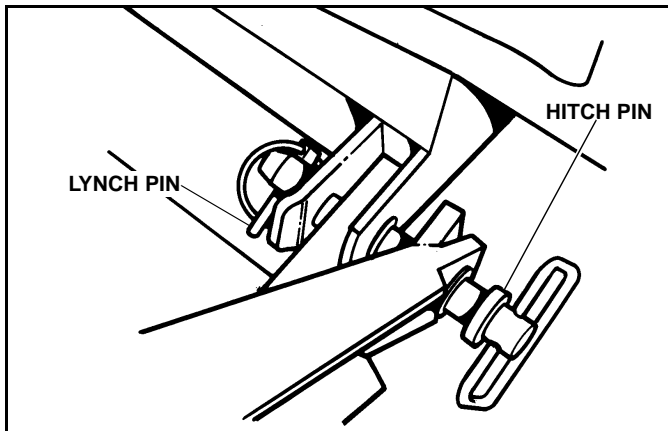

Figure 1-22

*NOTE: If the plow and vehicle are not level with each other, install one lower Hitch Pin and then, using the Rocker Switch on the pump cover, (See Figure 1-21) adjust the A-Frame height to allow installation of the second lower Hitch Pin.*

9. After the lower Hitch Pins and Lynch Pins have been installed, place the Rocker Switch in the lower position to allow the Jackstand to be raised off the ground. Then rotate the Jackstand forward and upward and latch it in the transport storage position with the Spring Pin. (See Figure 1-21)

**IMPORTANT:** The end of the Spring Pin fits into a short tube on the side of the Bellcrank assembly. If the Pin is not retained in this tube, the Jackstand may become loose and fall down during plowing or transport.

10. Raise the Lift Link and Light Bar manually to align the upper Hitch Pin mounting lugs and slide the upper Hitch Pin into place. Install the Lynch Pin to retain the Hitch Pin. (See Figure 1-23)

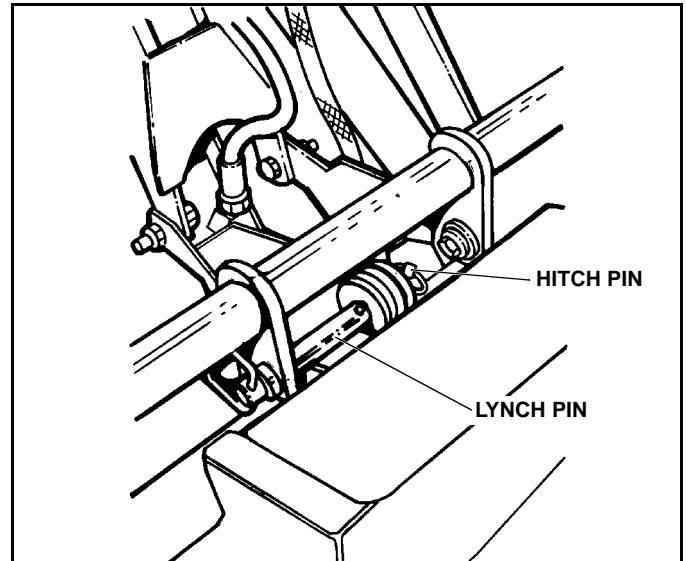

Figure 1-23

11. Connect the Snow Plow Light Harness to the vehicle light harness.

12. Move the Rocker Switch on the Pump Cover to the "lower" position to allow normal Snow Plow operation.

#### Installing The Cylinder Lock Clamp



## WARNING

- Always install the Cylinder Lock Clamp when the plow blade is raised and the operator is not engaged in plowing operations. Equipment failure or inadvertent operation of the control switches while driving could allow the plow blade to fall, resulting in serious injury.

- Ensure Engine is OFF and set parking brake before installing the Cylinder Lock Clamp, vehicle movement, equipment failure or inadvertent operation of the control switches during installation could allow the plow blade to fall, resulting in serious injury.

**FAILURE TO HEED CAN RESULT IN SERIOUS INJURY OR DEATH.**

1. Raise the plow to the full UP position.
2. Turn ignition switch OFF and apply the emergency brake.
3. Remove the Pins from the Cylinder Lock Clamp and spread it apart.

4. Position the Cylinder Lock Clamp around the exposed (chrome) portion of the Lift Cylinder and install the Pins. Install the Hairpin Cotter Into the Pins. (See Figure 1-24)

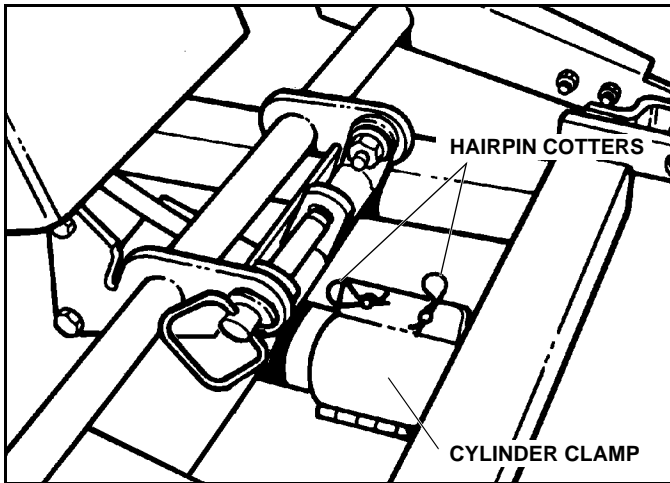

Figure 1-24

## Operation Check and Inspection

1. Raise plow to the full up position. Check to make sure snowplow headlamp beam is not being impaired by the top of the Blade assembly. If the headlamp beam is being impaired, adjust the light bar. (See instructions in Light Kit)

2. Raise and lower the plow while inspecting the routing of the Wiring Harness on the plow to insure that it does not come in contact with any sharp edges or moving parts. If necessary, revise the Harness routing to obtain clearance and tape or tie the Harness to maintain clearance.

3. Extend and retract each Wing assembly and inspect for proper clearances of all moving parts.

## Disk Shoe Adjustment

**IMPORTANT:** This Plow is equipped with three (3) Disk Shoes. Two Disk Shoes are located at the outboard end of each Wing. The third Disk Shoe is located under the Trip Springs on the Center Plow Assembly. All three Disk Shoes must be adjusted equally.

**IMPORTANT:** To ensure the best function of this Snow plow, it is a requirement that all three Disk Shoes be used at ALL times.

1. Drive the vehicle, with Snow Plow mounted, onto a smooth, level surface. Park the vehicle, move the Plow Wings until the Wings are straight out on each side and lower the Plow to the ground.

2. Turn ignition switch OFF and apply the emergency brake.

3. Inspect both Float Limiter Screws and be sure that the hex head of the screws are not contacting the wear plate underneath the hex head of the screw. If necessary, adjust each screw upward so that the screw head is not contacting the wear plate when the pivot tubes are vertical.

*NOTE: After Disk Shoe Adjustment is completed, the Float Limiter Adjustment must be made. (See "Float Limiter Adjustment" on page 15)*

4. Place a level against the front of the Wing Pivot Tubes and pull or push the top of the Center Section until the level indicates that the Pivot Tubes are vertical (Not tipped either forward or rearward).

5. Determine whether the Center Disk Shoe or the Center Wearstrip is off the ground and measure the amount that it is off the ground. (See Figure 2-1)

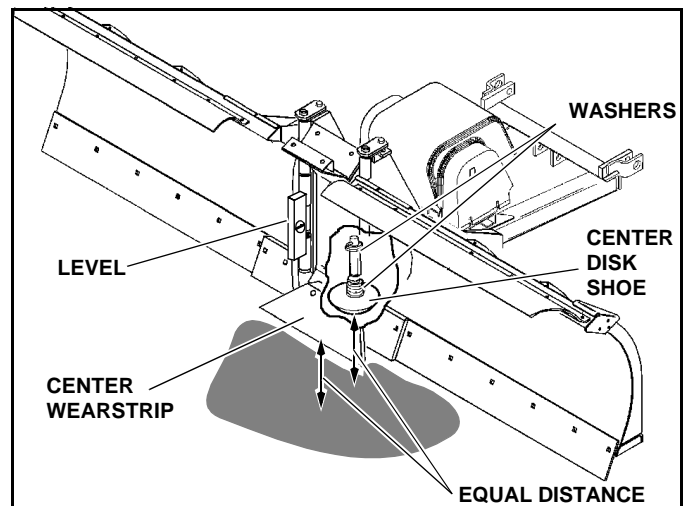

Figure 2-1

*NOTE: Gap may be measured by sliding shims or washers between the ground and/or the Center Disk Shoe or the Center Wearstrip, then measuring the shim/washer stack. The Center Disk Shoe will need to be adjusted until the Disk Shoe and Center Wearstrip both contact the ground at the same time.*

- If the Center Disk Shoe was off the ground - Washers must be ADDED below the Disk Shoe Mounting Tube. If the Center Wearstrip was off the ground - Washers must be REMOVED from below the Disk Shoe Mounting Tube.

**IMPORTANT: If Washers must be added, add one Washer LESS than the amount the Disk Shoe was off the ground. If Washers must be removed, remove one Washer MORE than the amount the Wearstrip was off the ground.**

6. Raise Plow and place suitable blocking under the Plow to allow at least eight inches (8") of clearance from the bottom of the Center Disk Shoe to the ground.

7. Lower Plow onto blocking.



## WARNING

**Keep hands and feet clear of Wings and Center Section when setting blocking and lowering Plow. Moving or falling assemblies could result in serious injury.**

**FAILURE TO HEED CAN RESULT IN SERIOUS INJURY OR DEATH.**

8. Adjust Center Disk Shoe assembly by removing the Disk Shoe Mounting Pin and adding or subtracting Washers on the top or bottom of the Disk Shoe Mounting Bracket as required according to measurements taken in step #4.

9. After the Center Disk Shoe position is properly adjusted, place washers on the Disk Shoe Stem - above the Disk Shoe Mounting Bracket, and below the Retaining Pin - to remove all up and down movement of the Disk Shoe in the Bracket. Failure to do this will result in excessive wear of the holes in the Disk Shoe Mounting Bracket and will also result in bending the Disk Shoe Stem.

10. After the Center Disk Shoe adjustment is completed, lower the Plow to the ground. If this Disk Shoe adjustment is correct, the Center Disk Shoe and the Center Wearstrip will both be on the ground and the Wing Tubes will be vertical (Recheck the Wing Tubes with a level). If Wing Tubes are not vertical, repeat steps #3 to #9 until Wing Tubes are vertical.

*NOTE: If assembling and mounting a Snow Plow for the first time, the adjustment of the Center Disk Shoe can be done with just the Center Section Mounted on the vehicle, prior to assembling the Wings onto the Center Section of the Plow.*

11. With each Wing extended straight out to each side, measure the amount the Wing Shoes are off the ground, or if they are on the ground, measure the amount that the Wearstrip is off the ground (measured in front of the Disk Shoe Bracket).

12. Raise Plow and place suitable blocking under the Plow to allow at least six inches (6") of clearance from the bottom of the Wing Disk Shoes to the ground.

13. Lower Plow onto blocking.



## WARNING

**Keep hands and feet clear of Wings and Center Section when setting blocking and lowering Plow. Moving or falling assemblies could result in serious injury.**

**FAILURE TO HEED CAN RESULT IN SERIOUS INJURY OR DEATH.**

14. Adjust each Disk Shoe assembly by removing Disk Shoe mounting Pin and adding or subtracting Washers on the top or bottom of the Disk Shoe Mounting Bracket as required according to measurements taken in step #11 (See Figure 2-2)

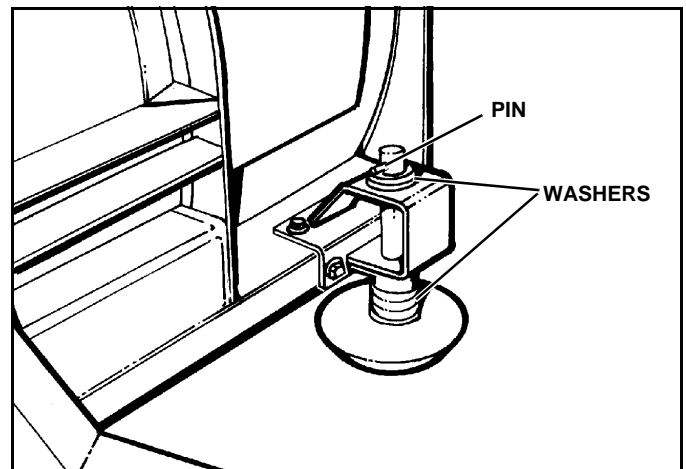

**Figure 2-2**

15. After the Disk Shoe position is properly adjusted, place washers on the Disk Shoe Stem - above the Disk Shoe Mounting Bracket, and below the Retaining Pin - to remove all up and down movement of the Disk Shoe in the Bracket. Failure to do this will result in excessive wear of the holes in the Disk Shoe Mounting Bracket and will also result in bending the stem of the Disk Shoe.

16. After the Wing Disk Shoe adjustment is complete, lower the Plow to the ground. If this Disk Shoe adjustment is correct, the Shoes and the Wearstrips will all be on the ground at the same time, if not, repeat steps #11 to #15.

17. Move the Wings forward and rearward, if the Wing Wearstrips and the Center Wearstrips are not on the ground at all times recheck the position of the Wing Pivot Tubes. The Tubes must be Vertical, if they are not vertical, the Center Disk Shoe will need to be adjusted.

## Trip Spring Adjustment

*NOTE: The Trip Springs are factory installed and adjusted, but adjustment should be checked during Plow Set-Up and installation.*

Springs are properly adjusted when two or more coils allow a 0.010" feeler gauge to just pass between the separated coils. (A 3 x 5 post card is approximately the same thickness.)

If readjustment is required:

1. Raise the plow to transport position and place blocking under the plow to prevent the plow from inadvertently dropping.
2. Turn off the vehicle ignition, apply the parking brake and remove the vehicle ignition key.
3. Check to make sure that the Spring is installed as illustrated with open end of top loop facing vehicle. (See Figure 2-3)
4. Using a 15/16" socket wrench through the holes in the Bottom Plate of the Main Frame, loosen the two (2) 5/8" Nuts on the Trip Spring Eyebolts. (See Figure 2-3)



### CAUTION

- Do not overtighten springs. If more than 0.015" (1/64") gap appears between coil with plow at rest damage could occur to equipment during plowing.
- Spring must be installed with open end of top loop facing vehicle. Bottom loop position will vary.

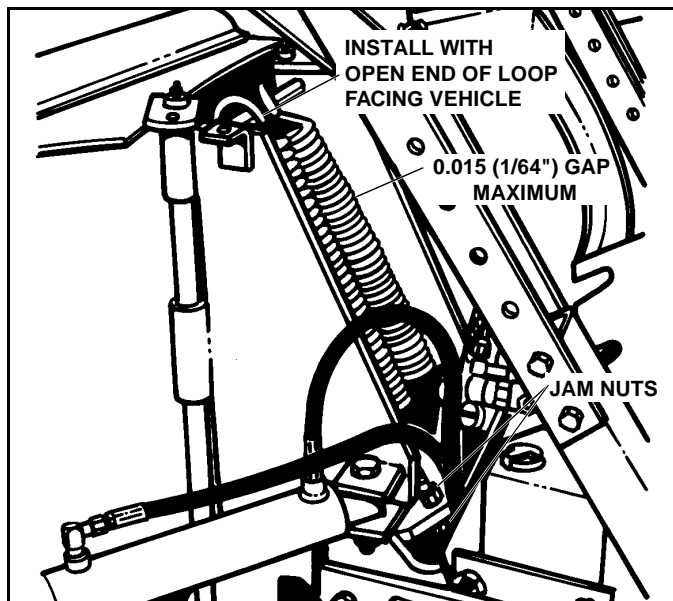

Figure 2-3

5. After the two lower nuts have been loosened, the two upper nuts can be rotated on the eye bolts to allow the Trip Springs to be shortened or lengthened.
6. While holding the two upper nuts, re-tighten the two lower nuts and then re-check the spring adjustment.

## Float Limiter Adjustment

**IMPORTANT:** The Disk Shoes must be properly adjusted prior to adjusting the Float Limiter. If the shoes are not properly adjusted, the Float Limiter Adjustment cannot be properly made.

1. With the vehicle and Snow Plow on a smooth, level surface move the Wings forward into the "Scoop" position and lower the Plow to the ground.

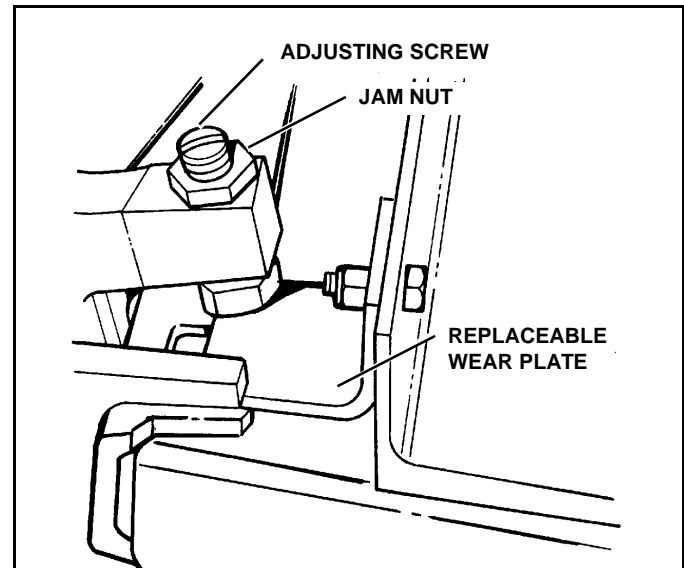
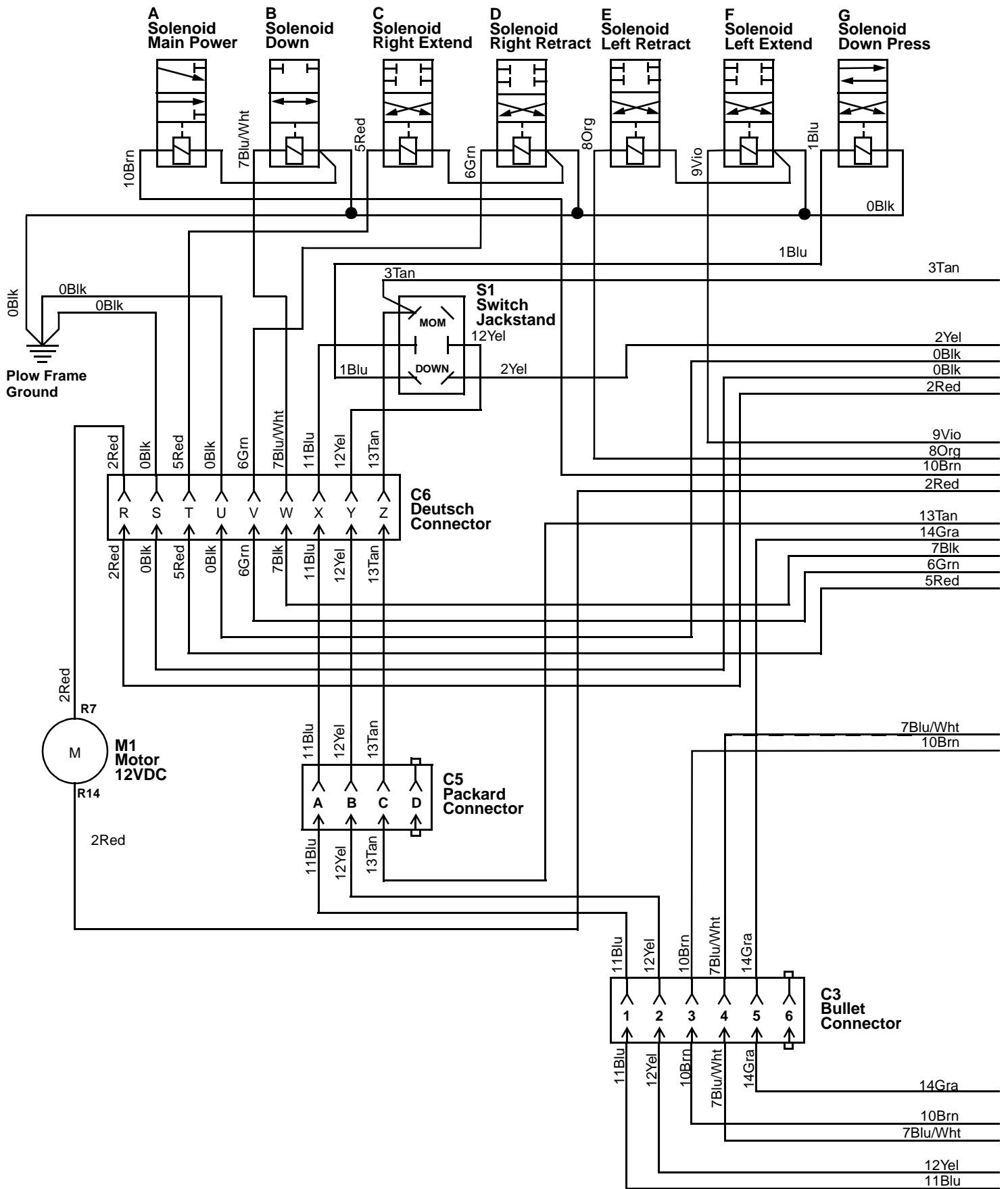

Figure 2-4

2. Loosen the 5/8" Jam Nut on the top of the float limiter Adjusting Screw.
3. Using the screwdriver slot in the top of the Float Limiter Adjusting Screw, turn the Adjusting Screw down until the hex head of the Adjusting Screw touches the surface of the replaceable Wear Plate.
4. Turn the Adjusting Screw up two turns to provide a gap between the wear plate and the head of the Adjusting Screw for proper float allowance.
5. While holding the Adjusting Screw driver slot, to prevent turning of the Adjusting Screw, tighten the 5/8" Jam Nut to lock the Adjusting Screw and prevent turning of the Adjusting Screw during operation.









# W1 Wire Harness - Vehicle

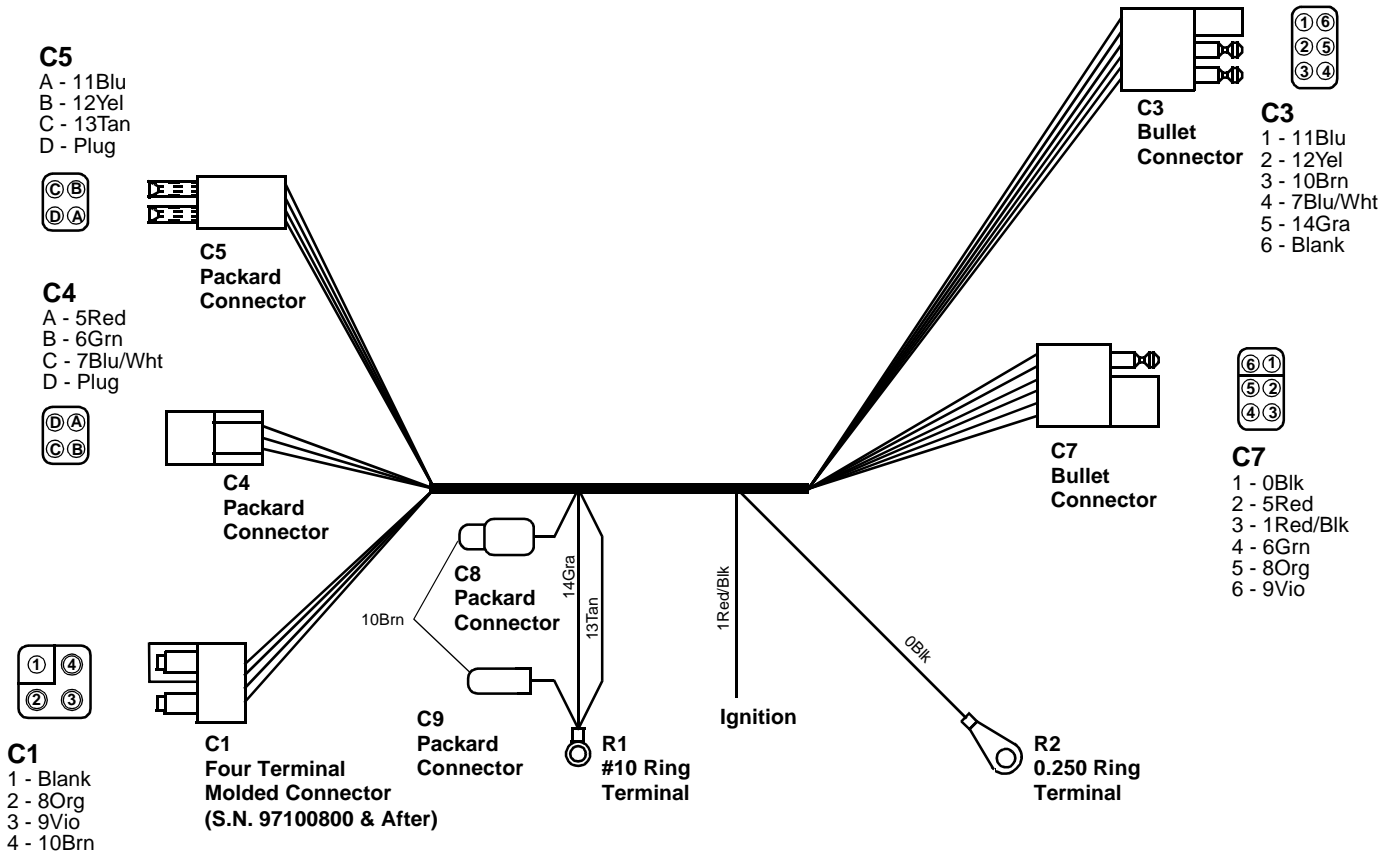

# W2 Wire Harness - Control Box "B"

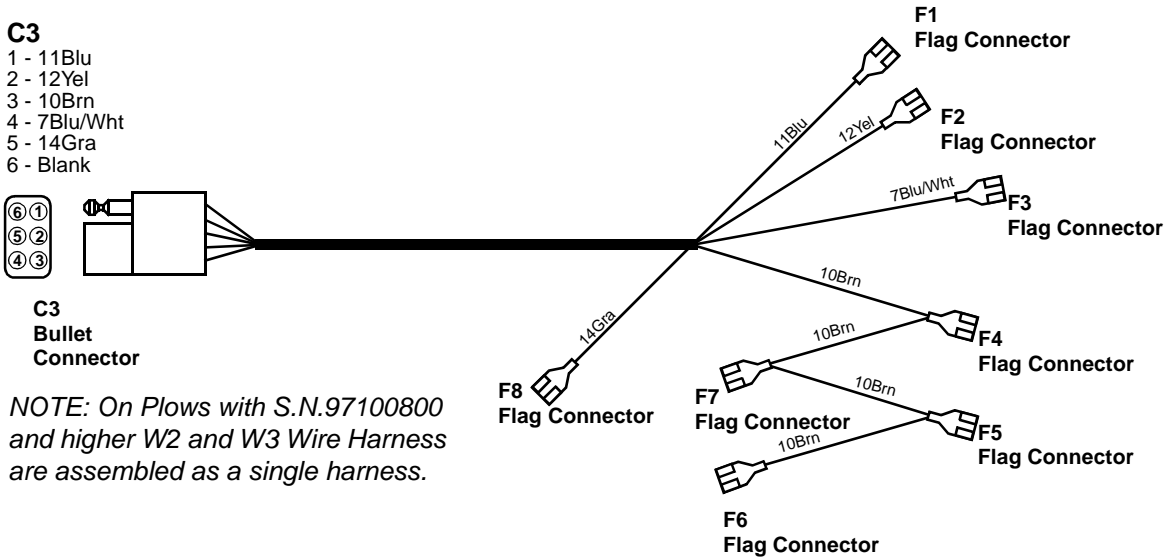

# W3 Wire Harness - Control Box "A"

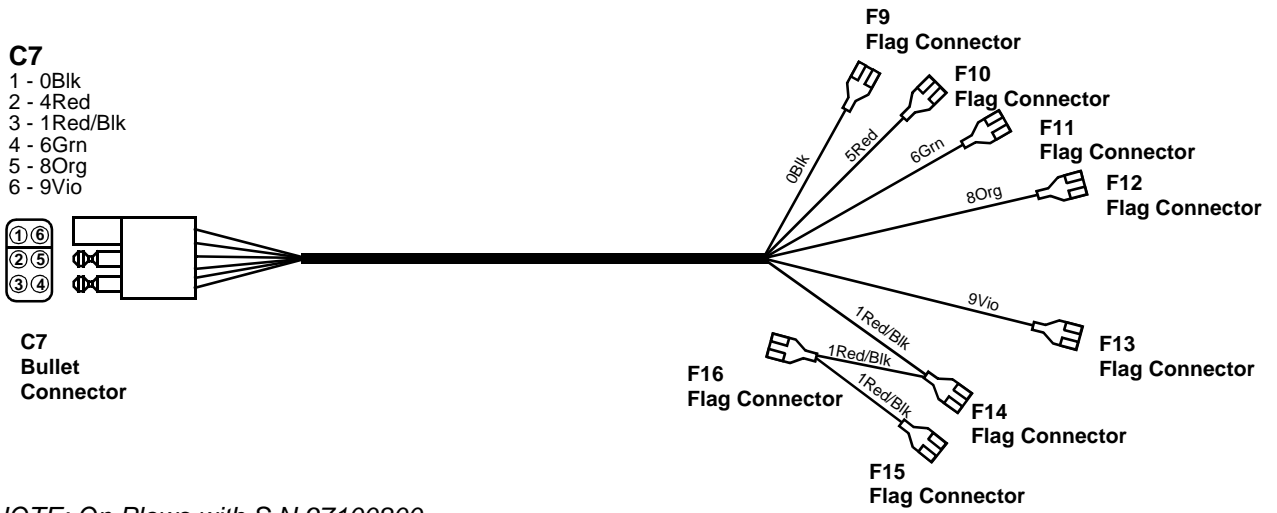

NOTE: On Plows with S.N.97100800 and higher W2 and W3 Wire Harness are assembled as a single harness.

# W4 Wire Harness - Vehicle End Control

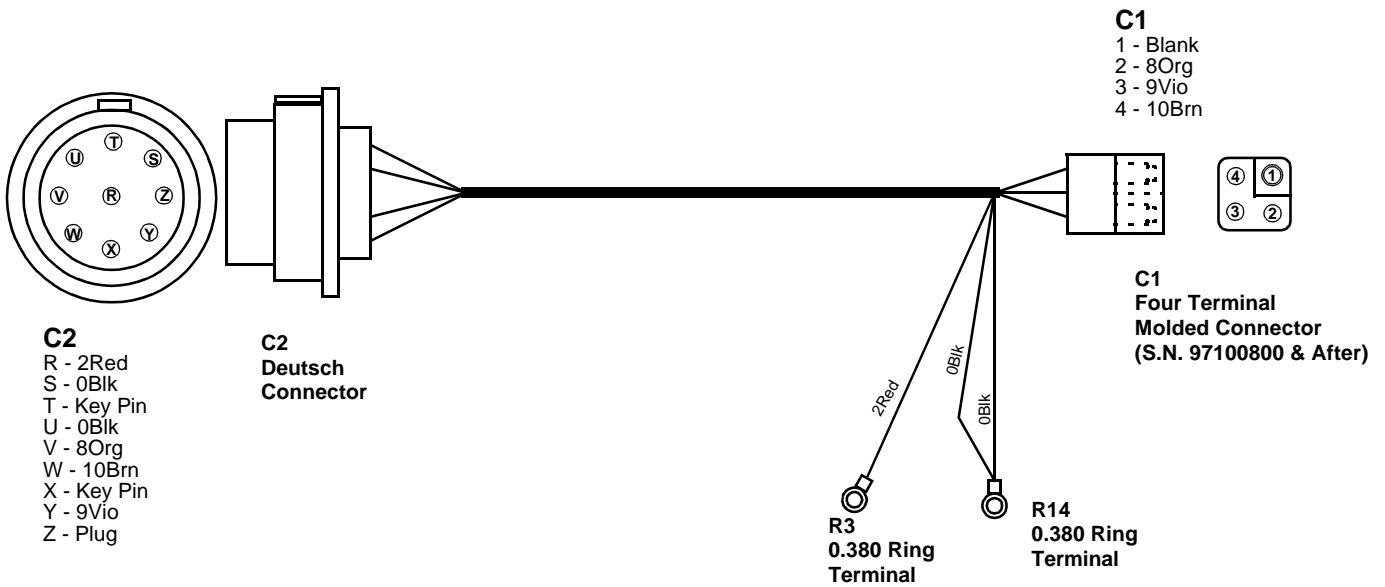

## W5 Wire Harness - Vehicle End

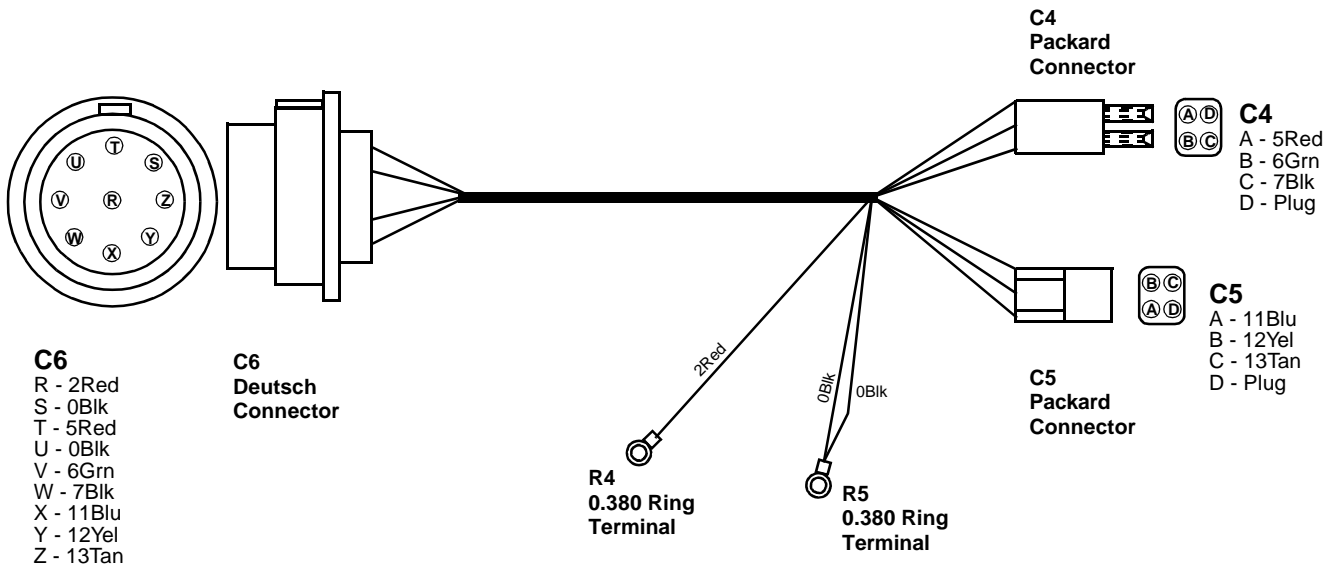

## W6 Wire Harness - Pump End Control

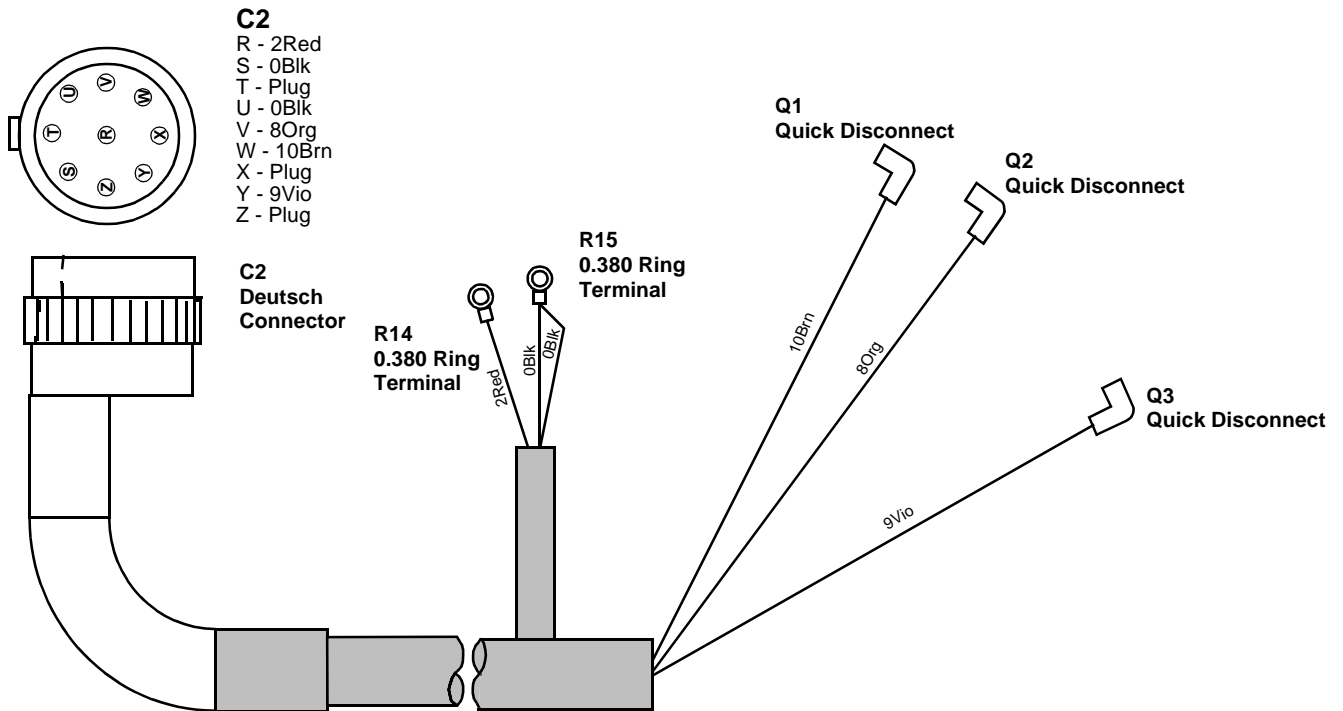

# W7 Wire Harness - Pump End Main

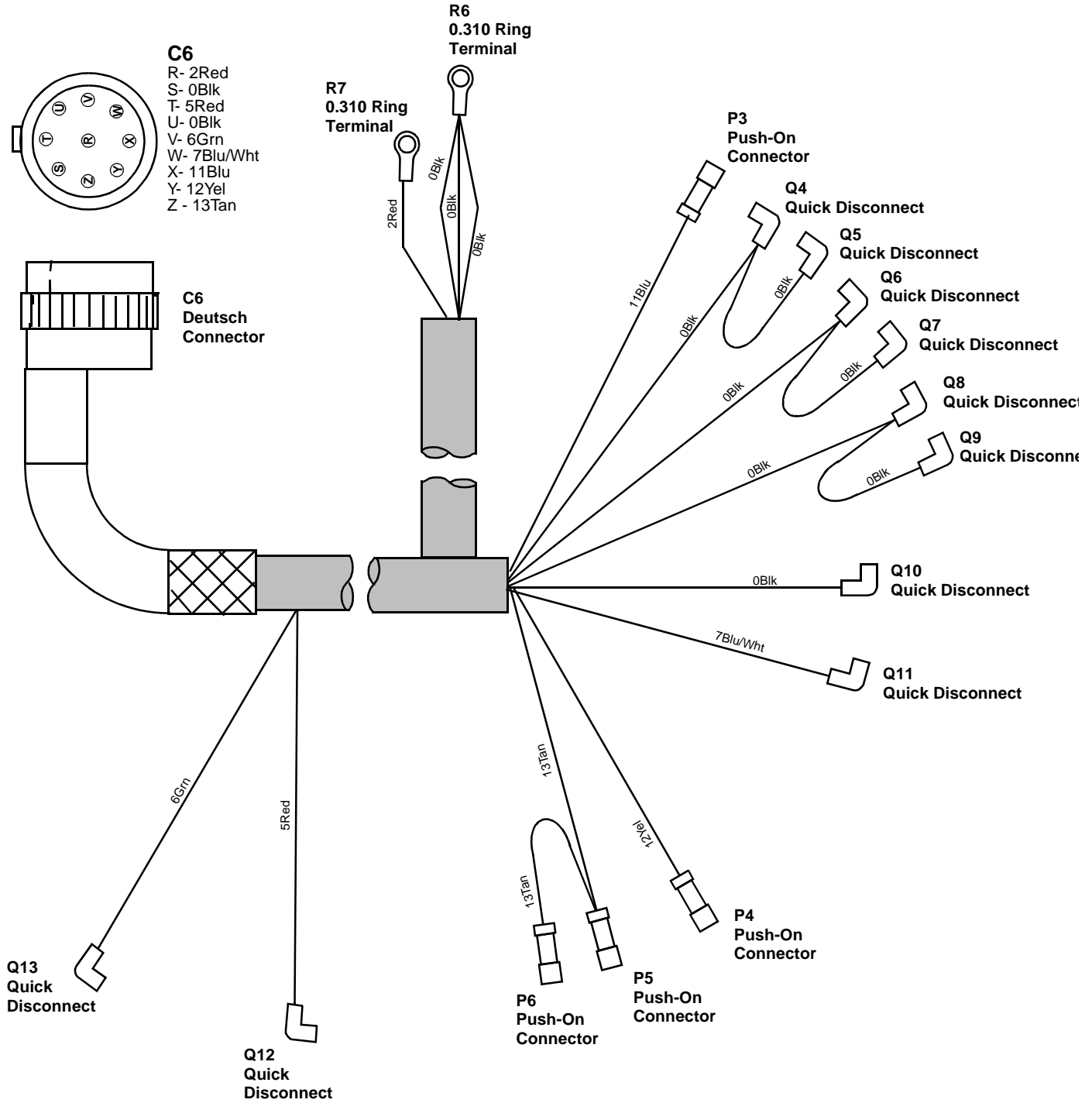

## W8 Wire Harness (No Longer Used)

## W9 Wire Harness - Battery Power



## W10 Wire Harness - Battery Ground

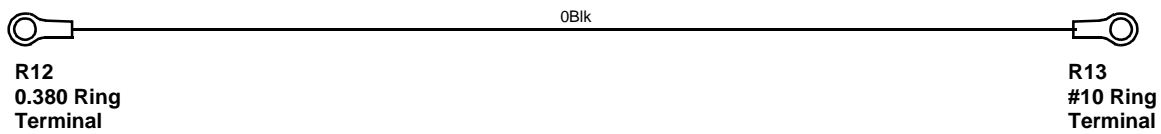

## W11 Wire Harness - Solenoid Switch Power





## W12 Wire Harness - Jackstand Switch Jumper

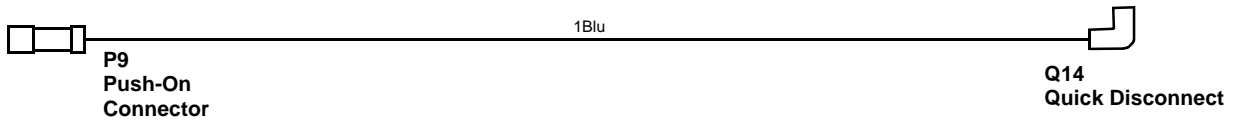





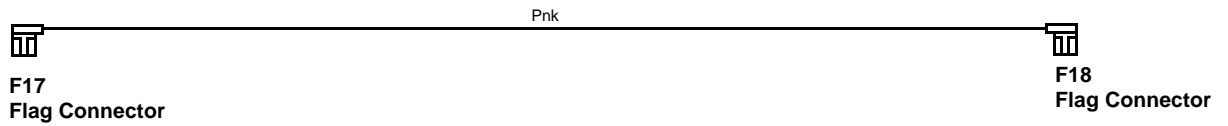

## W13 Wire Harness - Jackstand Switch Jumper



## W14 Wire Harness - Control Box Jumper (2 Req.)



# TORQUE SPECIFICATIONS

SAE Grade and Head Markings	1 or 2 No Marks 	5    5.1    5.2 	8    8.2 
SAE Grade and Nut Markings	2 No Marks 	5 	8 

	Grade 1		Grade 2		Grade 5, 5.1 or 5.2		Grade 8 or 8.2	
	Lubricated <sup>a</sup>	Dry <sup>b</sup>	Lubricated <sup>a</sup>	Dry <sup>b</sup>	Lubricated <sup>a</sup>	Dry <sup>b</sup>	Lubricated <sup>a</sup>	Dry <sup>b</sup>
SIZE	lb-ft	lb-ft	lb-ft	lb-ft	lb-ft	lb-ft	lb-ft	lb-ft
8-32			14*	19*	22*	30*	31*	42*
10-24			21*	27*	32*	43*	45*	60*
1/4	2.8	3.5	4.5	5.5	7	9	10	12.5
5/16	5.5	7	9	11	15	18	21	26
3/8	10	13	16	20	26	33	36	46
7/16	16	20	26	32	41	52	58	75
1/2	25	31	39	50	63	80	90	115
9/16	36	45	56	70	90	115	130	160
5/8	50	62	78	100	125	160	160	225
3/4	87	110	140	175	225	280	310	400
7/8	140	175	140	175	360	450	500	650
1	210	270	210	270	540	675	750	975

DO NOT use these values if a different torque value or tightening procedure is given for a specific application.

Fasteners should be replaced with the same or higher grade. If higher grade fasteners are used, these should only be tightened to the strength of the original.

<sup>a</sup> "Lubricated" means coated with a lubricant such as engine oil, or fasteners with phosphate and oil coatings.

<sup>b</sup> "Dry" means plain or zinc plated without any lubrication

\* Values with asterisk are in lb-in.

# DEALER PRE DELIVERY CHECKLIST

The following inspections **MUST** be accomplished prior to delivering the snowplow to the customer. Place an X  in the box after accomplishing each item on the checklist.

## CHECK THAT

- Parts have not been damaged in shipment. Repair or replace items that are loose, dented or missing.
- All covers, guards and decals are in place and attached securely.
- All pivot pins and cotters are installed and secure.
- Trip springs are adjusted.
- Disk Shoe assemblies are installed and adjusted.
- Float Limiters are properly adjusted.
- Snow plow headlamps are adjusted properly.
- Snow plow headlamps are functional.
  - High Beam                       Low Beam                       Park Lamps
  - Left Turn                       Right Turn                       Headlamp Beam Aimed Correctly
- Cylinder lock clamp is installed.

Start the vehicle engine and place an X  in the box after accomplishing each item on the checklist.

## CHECK THAT

- ALL** blade functions work properly.
- Cylinders, hoses and fittings **DO NOT** leak.
- Listen for abnormal noises or vibrations; Repair or replace as necessary.
- The Power Unit is properly filled.

# DELIVERY CHECKLIST

The following checklist is to be accomplished with the customer present, Place an X  in the box after accomplishing each item on the checklist.

- After giving the Customer his Owner's Manual, instruct him to read it **PRIOR** to operating the Snow Plow. If he has any questions or does not understand part(s) of the Manual, ask him to contact the Dealer for answers or explanations **BEFORE** operating the unit.
- Record the Serial Numbers, Date of Purchase, Purchaser's Name and Address, and the Dealers Name, Address and Phone Number in the space provided on Page 1 of the Owner's Manual.
- Explain connect and disconnect procedures.
- Explain the necessity of Disk Shoe usage at all times to ensure optimum plow performance.
- Explain the necessity of proper Float Limiter adjustment to ensure optimum plow performance.
- Demonstrate power Jackstand function and operation.
- Demonstrate cylinder Lock Clamp installation.
- Demonstrate Down Pressure hydraulic system function and operation.
- Fill out Warranty Registration Card and mail COPY 1 to the factory to validate Warranty. NO Warranty claims can be honored if the Warranty Card is not on file at the factory.**

**SNO-WAY INTERNATIONAL, INC.**

