



**Assembly
&
Installation Instructions**
FOR
SUBFRAME COMPONENTS PACKAGE 99100300
AND
SUBFRAME NOSE PIECE PACKAGE 96103002

TO FIT
1997 & LATER FORD F150 PICKUP
1997 & LATER FORD F250 LD PICKUP
1997 & LATER FORD EXPEDITION



1. **THINK SAFETY, ALWAYS WEAR SAFETY GLASSES WHEN PERFORMING THE OPERATIONS PRESCRIBED IN THESE INSTRUCTIONS**
2. **READ ALL INSTRUCTIONS CAREFULLY BEFORE ATTEMPTING INSTALLATION**
3. **BEFORE BEGINNING WORK MAKE SURE TO SET PARKING BRAKE AND CHOCK WHEELS**



MINIMUM VEHICLE RECOMMENDATIONS

Heavy Duty Alternator Heavy Duty Battery
 Manufacturers Snow Plow Package

ASSEMBLY TOOLS NEEDED

Drill Bits 1/4", 17/32"
 Impact Sockets 7/16" – 1-3/8"
 Wrenches 7/16" – 1-3/8"
 Torque Wrench
 Center Punch and Hammer
 Clamping Device ("C", Bar, type device...)
 Rat Tail Pry Bar
 Hacksaw

NOTE: On some vehicles it may be necessary to use a form of load booster to decrease the vehicle's front suspension sag with the snow plow in place. This can be accomplished with the use of supplementary air bags, booster springs, or similar load boosting devices. Since there are different load boosting devices available, it will up to the customer/end user to decide and purchase the product to suit the application, and not the responsibility of Sno-Way International, Inc.

INSTALLATION NOTES

1. **Unless otherwise specified, mount all Sub-Frame Components to vehicle before tightening any hardware.**
2. **It is recommended that LOCTITE®, or similar thread locking product, be used on ALL mounting hardware (i.e. Nuts, Cap Screws, Bolts, etc.).**
3. Vehicle should be parked on a level surface with a normal vehicle load on the FRONT suspension.
4. Items in parentheses () refer to quantity required for this step. Items in parentheses with a pound sign (#) indicate the part number as found in the parts list on the last page of this document.
 Example: (2) 5/8" x 1-1/2" Cap Screws (#7).
5. It maybe necessary to relocate license plate holder. Relocate under the driver's side headlight by drilling new holes in the bumper. Check state and local laws for placement, if needed.

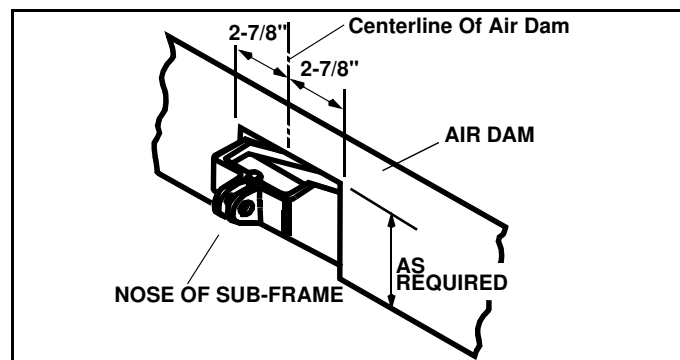

3. Place (2) Nut Plates (#6) inside vehicle frame and align holes with the tow hook mounting holes. Align (1) Front Crossmember (#2) with tow hook mounting holes and Nut Plate holes. Align (2) Spacer Plates (#15) with holes and secure parts to vehicle using (4) 1/2 x 2-1/2" Cap Screws (#11), 1/2" Lock Washers (#13) and 1/2" Flat Washers (#14). (See Installation Notes #1 and #2)

MOUNTING INSTRUCTIONS

F-250 (LD) ONLY:

1. Remove splash guard and all remaining hardware from the underside of the vehicle. Retain with hardware, for future reinstallation if Sub-Frame is removed.
2. Relocate licence plate if required. (See Installation Note #5)
3. Remove tow hooks and hardware. Retain for reinstallation if Sub-frame is removed.

F-150 & F-250 (LD):

1. Remove the vehicle front bumper assembly, retain hardware for later use.
2. Remove air dam from bumper, with hardware and retain for future use if Sub-Frame is removed.

NOTE: Front air dam can be modified to clear Sub-Frame by cutting dam to allow clearance for nose of Sub-Frame. Cut air dam as shown and remove cut section or fold back for when nose piece is removed.

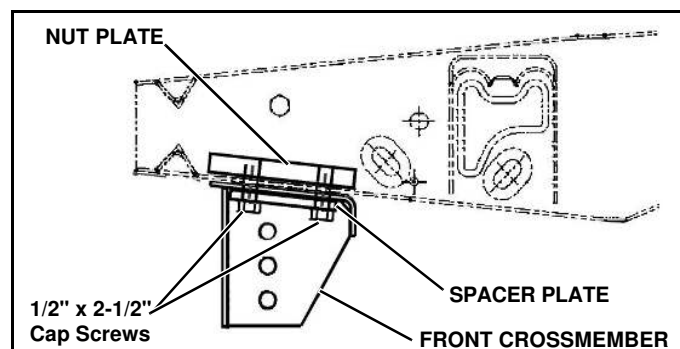

4. Place (1) Rear Crossmember (#3) over (1) Sub-Frame Nose Piece (#1) and secure as follows:
 - Rear Mounting - (2) 5/8" x 1-1/2" Cap Screws (#7), and 5/8" Nylock Nuts (#10). (See Installation Notes #1 and #2)
 - Front Mounting - (2) 5/8" x 3-1/2" Cap Screws (#8) and 5/8" Nylock Nuts (#10). (See Installation Notes #1 and #2)

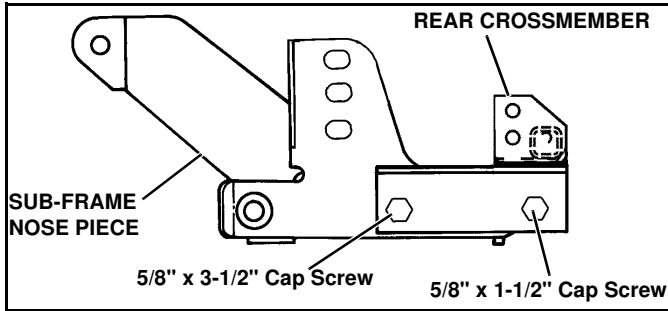

IMPORTANT: The Cap Screws securing the Sub-Frame to the Front Crossmember must be staggered with the front bolts being positioned in a lower set of holes than the side bolts. (Unless the holes are in the lowest possible position)

- Attach Sub-Frame assembly to Front Crossmember (#2) using (4) 5/8 x 1-1/2" Cap Screws (#7), 5/8" Flat Washers (#9) and 5/8" Nylock Nuts (#10). (See Installation Notes #1 and #2)

IMPORTANT: Height from the center of the lower Plow Mounting holes on the Sub-Frame into the ground should be between 9" and 11" to insure proper operation.

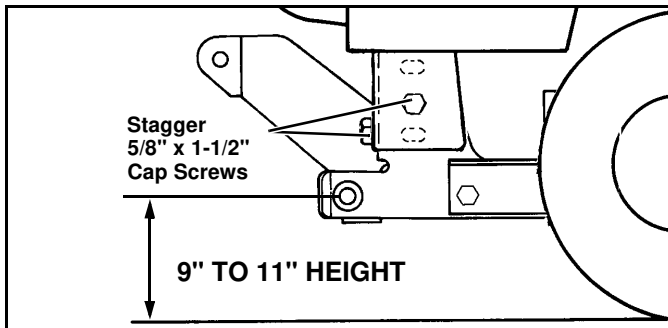

NOTE: Tighten Nuts to where the Rear Mounting Brackets and Rear Crossmember are snug to each other for proper alignment in Step 6 and 7.

- Align Rear Mounting Brackets (#4) LH & (#5) RH, with top rear mounting holes of the Rear Crossmember. Insert (4) 5/8 x 1-1/2" Cap Screws (#7) and hold in place with 5/8" Nylock Nuts (#10).
- Align Rear Mounting Brackets lowest hole with the existing slot in the vehicle frame, insure the Mounting Brackets are tight with the bottom of the vehicle frame and, keeping the Sub-Frame Assembly **parallel** to the ground, clamp in place.

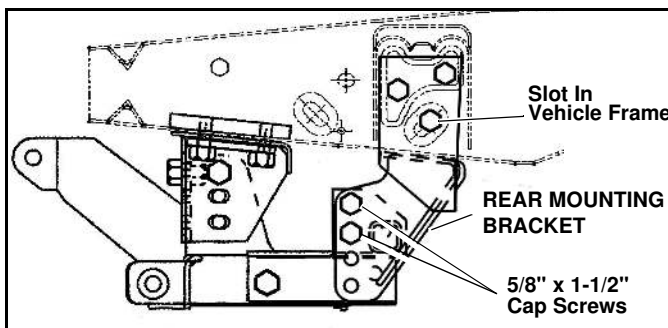

WARNING

Beware of brake and fuel lines secured to inside wall of frame rails when drilling holes in vehicle frame!

FAILURE TO HEED CAN RESULT IN SERIOUS INJURY OR DEATH.

- Using the (4) holes in the Rear Mounting Brackets (#4) LH, & (#5) RH as a template, center punch and drill (4) 1/4" pilot holes through the outside of the vehicle frame rail. Remove both Mounting Brackets from the Vehicle and Sub-Frame Assembly. Drill out the 1/4" holes with a 25/32" drill through outside frame walls of the vehicle frame rails using the 1/4" pilot holes for alignment.

- Secure the Mounting Brackets and the Sub-Frame Assembly as follows:

- Reattach Mounting Brackets to Sub-Frame Assembly with the hardware mentioned in Step #6.
- Insert the Nut Plate Assembly (#16) through the opening in the front of the driver's side vehicle frame and align with drilled holes. Secure with (3) 1/2" x 1-1/2" Cap Screws (#12) and (3) 1/2" Lock Washer (#13). Repeat this procedure for the passenger side.

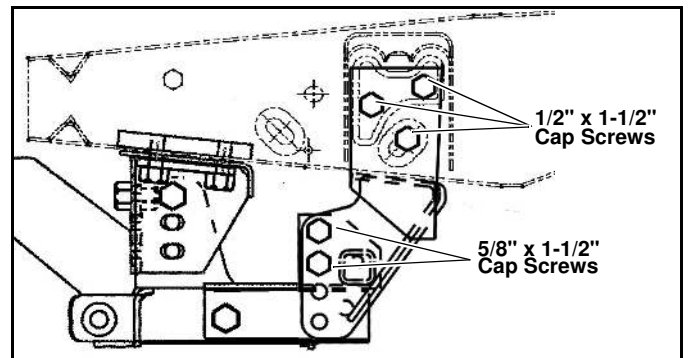

- Using the Torque Specification Chart provided, first torque the Nose Piece (#1) to the Front Crossmember (#2). Start by torquing the two front cap screws (#7) and then the two side cap screws (#7). Then torque the remaining cap screws **starting at the rear** and working forward.

TORQUE SPECIFICATIONS FOR STANDARD MACHINE HARDWARE

Bolt Size	GR.2 Dry	GR.5 Dry	GR.8 Dry	Metric Size	GR.8.8 Dry
1/4"	66*	9	12	M8	17
5/16"	11	17	25	M10	35
3/8"	20	30	45	M12	60
7/16"	32	50	70	M14	95
1/2"	50	75	110	M16	155
9/16"	70	110	150		
5/8"	100	150	220		
3/4"	175	260	380		
7/8"	170	430	600		
1"	250	640	900		

Note: These torque values are to be used for all hardware. Unless otherwise specified, all torque values must meet this specification.
Note: All torque values are in Ft.-Lbs unless otherwise stated
Note: *In-Lbs

REMEMBER After 5 to 10 hours of snowplow usage, re-torque all Cap Screw!

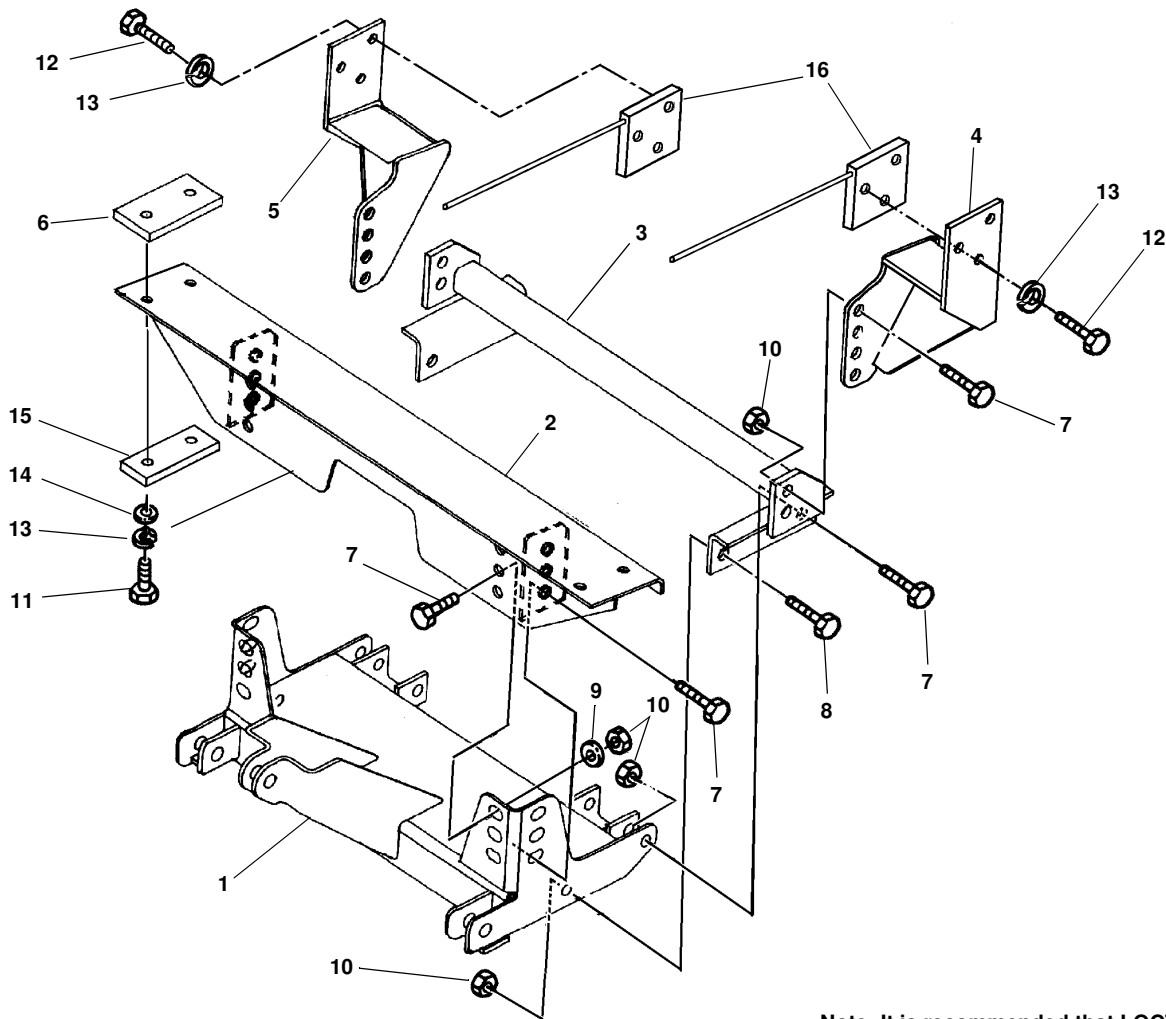

Note: It is recommended that LOCTITE®, or similar thread locking product, be used on ALL mounting hardware (i.e. Nuts, Cap Screws, Bolts, etc.).

ITEM	PART NO.	DESCRIPTION	QTY.
1	96103002	Sub-Frame, Nose Piece (96102896)	1
2	96102581	Crossmember, Front	1
3	96102722	Crossmember, Rear	1
4	96102589	Bracket, Rear, LH.....	1
5	96102593	Bracket, Rear, RH.....	1
6	96102726	Plate, Nut.....	2
7	98009115	Cap Screw, Hex Head, 5/8" -11NC x 1-1/2".....	10
8	98009042	Cap Screw, Hex Head, 5/8" -11NC x 3-1/2".....	2
9	98009039	Washer, Flat 5/8"	4
10	98009038	Nut, Hex, Nylock, 5/8" -11NC.....	12
11	98009015	Cap Screw, Hex Head, 1/2" -13NC x 2-1/2".....	4
12	98009010	Cap Screw, Hex Head, 1/2" -13NC x 1-1/2".....	6
13	98009012	Washer, Locking, 1/2"	10
14	98009011	Washer, Flat, 1/2"	4
15	96102787	Plate, Spacer	2
16	96104386	Assembly, Nut Plate.....	2

SNO-WAY® INTERNATIONAL, INC.

©2000 Sno-Way® International

