



**Assembly
&
Installation Instructions**

**FOR
SUBFRAME COMPONENTS PACKAGE 99100419
AND
SUBFRAME NOSE PIECE PACKAGE 96104413**

**TO FIT
1980 - 1991 Ford F150 / F250 / F350 & Bronco**



1. **THINK SAFETY, ALWAYS WEAR SAFETY GLASSES WHEN PERFORMING THE OPERATIONS PRESCRIBED IN THESE INSTRUCTIONS**
2. **READ ALL INSTRUCTIONS CAREFULLY BEFORE ATTEMPTING INSTALLATION**
3. **BEFORE BEGINNING WORK MAKE SURE TO SET PARKING BRAKE AND CHOCK WHEELS**



MINIMUM VEHICLE RECOMMENDATIONS

Heavy Duty Front Springs
 Heavy Duty Battery
 Heavy Duty Alternator
 Manufacturer's Snow Plow Package

NOTE: On some vehicles it may be necessary to use a form of load booster to decrease the vehicle's front suspension sag with snow plow in place. This can be accomplished with the use of supplementary air bags, booster springs, or similar load boosting devices. Since there are different load boosting devices available, it will be up to the customer/end user to decide and purchase the product to suit the application, and not the responsibility of Sno-Way International, Inc.

ASSEMBLY TOOLS NEEDED

Drill Bits 1/4", 17/32"
 Sockets 7/16" -- 1 1/8"
 Wrenches 7/16" -- 1-3/8"
 Torque Wrench
 Center Punch and Hammer
 Clamping Devices ("C", Bar, type device....)
 Rat Tail Pry Bar
 Hacksaw

INSTALLATION NOTES

1. **Unless otherwise specified, mount all Sub-Frame Components to vehicle before tightening any hardware.**
2. **It is recommended that LOCTITE®, or similar thread locking product, be used on ALL mounting hardware (i.e. Nuts, Cap Screws, Bolts, etc.).**
3. Vehicle should be parked on a level surface with a normal vehicle load on the FRONT suspension.
4. Items in parentheses () refer to quantity required for this step. Items in parentheses with a pound sign (#) indicate the part number as found in the parts list on the last page of this document.
 Example: (2) 5/8" x 1-1/2" Cap Screws (#9).
5. It may be necessary to relocate license plate holder. Check state and local laws for placement, if needed.

wall of the vehicle frame. Secure tightly using (4) 1/2"-1 1/2" Cap Screws (#10), (4) Flat Washers (#9) and (4) Nylock Nuts (#14).

3. Reinstall the front Bumper, using (4) 1/2" x 2 1/4" Carriage Bolts (#8), (4) Flat Washers (#9) and (4) Nylock Nuts (#14), placing (4) Spacer Tubes (#7) between the bumper and the frame.

• Vehicles from 1987-1991

1. Remove the front bumper from the vehicle.
2. Mount (1) Front Crossmember (#2) over the vehicle frame horns, align the mounting holes as close as possible to existing holes in the vehicle frame.
3. Raise and align the front bumper mounting bracket holes with the mounting holes of the Front Crossmember (#2). Keeping the front face of the Front Crossmember perpendicular to the ground, secure tightly using (4) 1/2" x 1 1/2" Cap Screws (#10), (4) Flat Washers (#9), and (4) Nylock Nuts (#14).

• Mounting instructions for all vehicles

1. Attach (1) Mounting Assembly (#1) to the Front Crossmember (#2) in the front set of vertical holes and secure using (6) 1/2" x 1 1/2" Cap Screws (#11) and (2) Nylock Nuts (#14).

NOTE: (4) of the holes in the Mounting Assembly are threaded, so no Nylock Nuts are needed for these (4) holes.

2. Align the bottom holes of (1) Rear Mounting Bracket (#3) & (#4) with the back set of vertical holes on the Mounting Assembly. Secure with (4) 1/2" x 2 1/4" Cap Screws (#12) and (4) 1/2" Nylock Nuts (#14). Clamp the Rear Mounting Brackets to the vehicle frame making sure the brackets are tight with the bottom and sides of the vehicle frame.

MOUNTING INSTRUCTIONS

• Vehicles from 1980-1986

1. Remove the front bumper from the vehicle.



WARNING

Beware of brake and fuel lines secured to inside wall of frame rails when drilling holes in vehicle frame!

FAILURE TO HEED CAN RESULT IN SERIOUS INJURY OR DEATH!

2. Mount (1) Front Crossmember (#2) over vehicle frame horns. Leave approximately a 1/4" gap between the top of the frame horn and the Front Crossmember. Clamp in place keeping the face of the Front Crossmember perpendicular to the ground. Using the side holes in the Front Crossmember as a template, drill (4) 1/4" holes then 17/32" holes through the outer

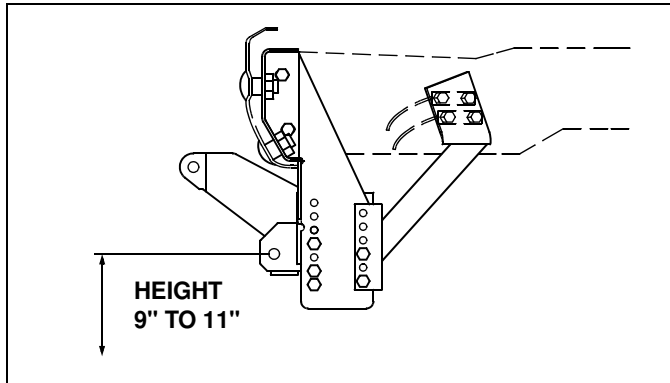
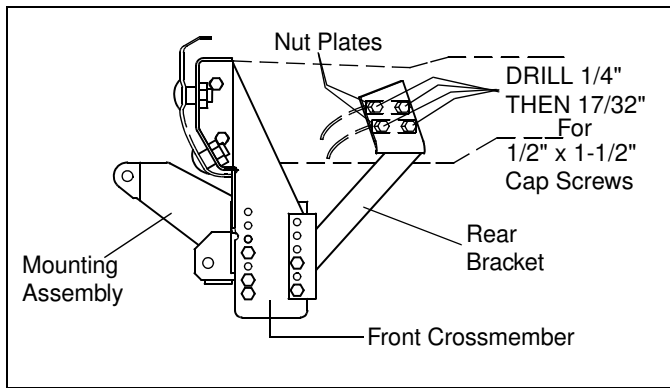

REMEMBER After 5 to 10 hours of snowplow usage, re-torque all Cap Screws!

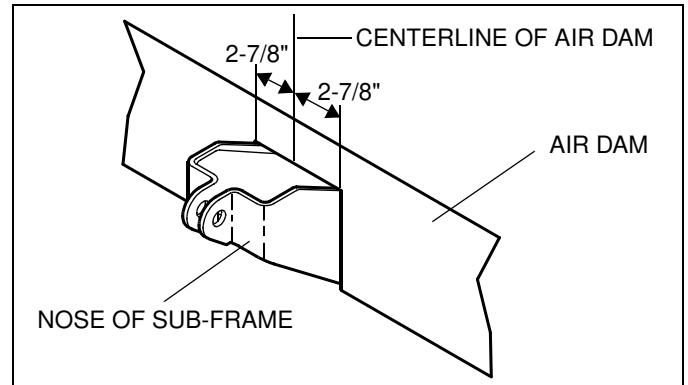

NOTE: (F150 & Bronco only) Front air dam can be modified by cutting dam to allow clearance for nose of Sub-frame. To modify air dam, measure 2-7/8" from each side of center and remove a section as required from between the marked areas to provide clearance for nose of sub-frame.

IMPORTANT: Height from the center of the lower plow mounting holes on the sub-frame to the ground should be between 9" and 11" to insure proper operation.

- Using the (8) holes in the Rear Mounting Brackets (#3) LH & (#4) RH as a template - center punch and drill (8) holes through the outer wall of the vehicle frame rails, by first using a 1/4" and then a 17/32" drill bit. Remove clamps and secure brackets using (8) 1/2" x 1 1/2" Cap Screws (#15) and (8) Lock Washers (#13) and inside the frame tubes using (1 set per side) Nut Plate Assembly (#5 LH & #6 RH). Wire handles should face to the front of the vehicle.
- Using the Torque Specification Chart below, torque all bolts starting at the rear and working forward.

TORQUE SPECIFICATIONS FOR STANDARD MACHINE HARDWARE					
Bolt Size	GR.2 Dry	GR.5 Dry	GR.8 Dry	Metric Size	GR.8.8 Dry
1/4"	66*	9	12	M8	17
5/16"	11	17	25	M10	35
3/8"	20	30	45	M12	60
7/16"	32	50	70	M14	95
1/2"	50	75	110	M16	155
9/16"	70	110	150		
5/8"	100	150	220		
3/4"	175	260	380		
7/8"	170	430	600		
1"	250	640	900		

Note: These torque values are to be used for all hardware. Unless otherwise specified, all torque values must meet this specification.
 Note: All torque values are in Ft.-Lbs unless otherwise stated
 Note: *In-Lbs

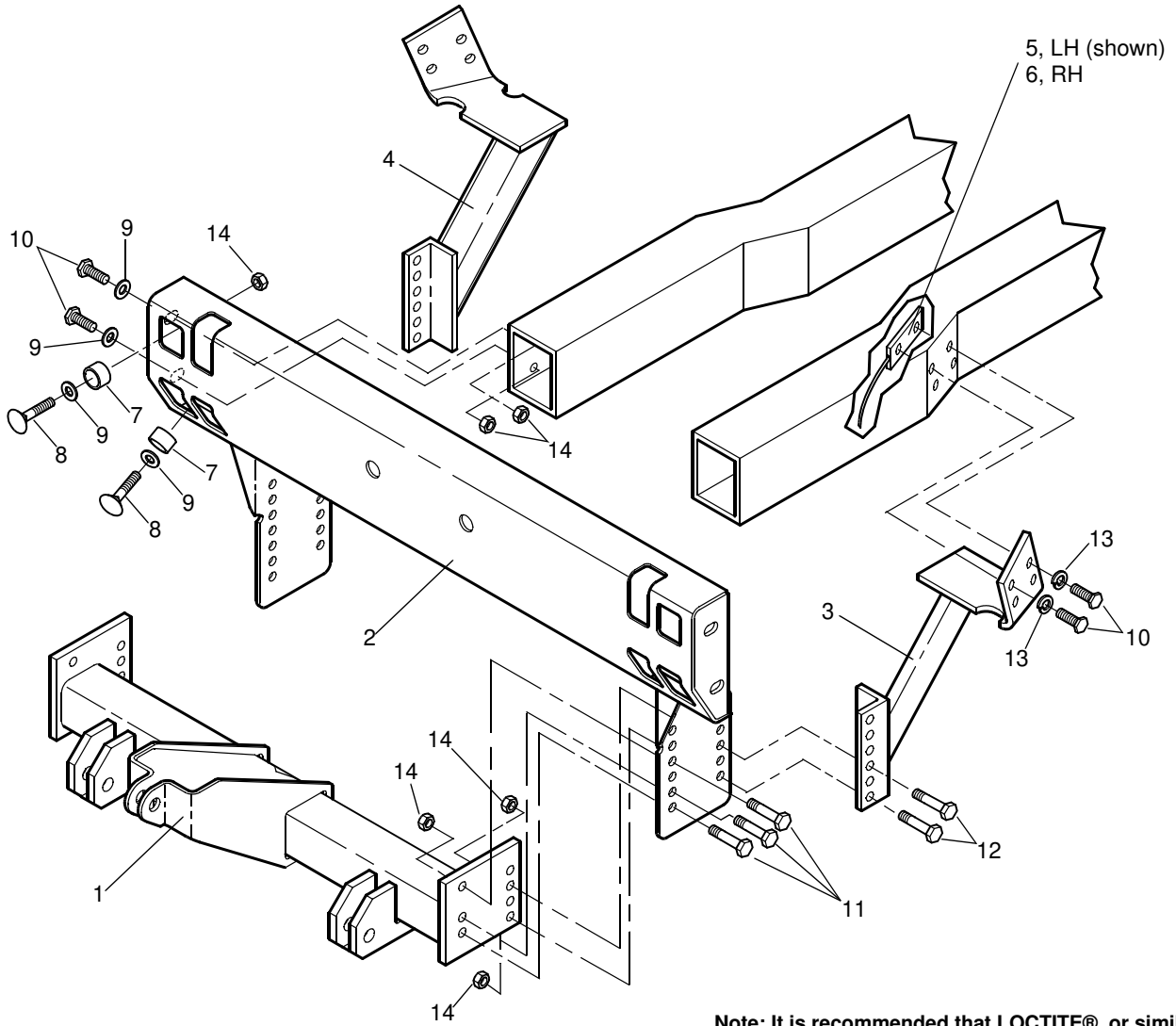

Note: It is recommended that LOCTITE®, or similar thread locking product, be used on ALL mounting hardware (i.e. Nuts, Cap Screws, Bolts, etc.).

ITEM	PART NO.	DESCRIPTION	QTY.
1	96104413	Mounting Assembly	1
2	96104416	Crossmember, Front.....	1
3	96104426	Rear Mounting Bracket, LH.....	1
4	96104429	Rear Mounting Bracket, RH.....	1
5	96100939	Plate, Nut, Left.....	2
6	96100938	Plate, Nut, Right	2
7	96101465	Tube, Spacer	4
8	98100067	Bolt, Carriage, 1/2"-13 x 2 1/4".....	4
9	98009011	Washer, Flat, 1/2"	8
10	98009010	Cap Screw, Hex Head, 1/2"-13 x 1/12".....	12
11	98100010	Cap Screw, Hex Head, 1/2"-13 x 2".....	6
12	98100062	Cap Screw, Hex Head, 1/2"-13 x 2 1/4".....	4
13	98009012	Washer, Lock, 1/2".....	8
14	98009013	Nut, Hex, Nylock 1/2"-13	18

SNO-WAY® INTERNATIONAL, INC.



©2000 Sno-Way® International