

SNO-WAY®

SNOW & ICE CONTROL EQUIPMENT

OWNER'S, INSTALLATION & PARTS MANUAL

V-BOX GAS AND ELECTRIC SPREADER UNITS

Sno-Way® , Down Pressure® and EIS® are registered trademarks of Sno-Way International, Inc.
ProControl™ , MegaBlade™ , V-Wing™ , E-Z Switch™ , Revolution™ , MaxAdjust™ , SpeedLock™ , and QuickJack™
are trademarks of Sno-Way International, Inc.

©2013 Sno-Way® International

97100701S

TABLE OF CONTENTS

	Page
INTRODUCTION	2
SAFETY	3
GENERAL INFORMATION	4
INSTALLATION.....	5
Mounting the Spreader Onto the Vehicle.....	5
Spinner Drive Chain Adjustment.....	5
Alignment of Spinner Chute Assembly	5
Wiring Harness and Cab Control Installation.....	6
Battery Safety.....	12
OPERATION.....	13
Starting the Engine	13
Stopping the Engine	13
Clutch Operation.....	13
External Shield Adjustment	14
Electric Spreader - On/Off Control Operation	15
Electric Spreader - Dual Variable Control Operation.....	16
MAINTENANCE	17
Engine Service and Repair.....	17
Electric Throttle Replacement	17
Dual Electric Controller Error Codes	18
Metri-Pack™ Connector Repair	19
TORQUE SPECIFICATIONS	21
WIRING SCHEMATIC - GAS SPREADER (Cab Control and Spreader Side).....	22
ELECTRICAL TROUBLESHOOTING - GAS SPREADER	23
WIRING SCHEMATIC - ELECTRIC SPREADER (On/Off Control).....	24
WIRING SCHEMATIC - ELECTRIC SPREADER (Dual Variable Control)	25
PARTS LISTS.....	26
CONVEYOR DRIVE AND IDLER.....	27
MOTOR PLATE & DRIVE - GAS SPREADER	29
MOTOR PLATE & DRIVE - ELECTRIC SPREADER	31
DUAL MOTOR PLATE & DRIVE - ELECTRIC SPREADER	33
ELECTRIC THROTTLE.....	35
DECAL AND DECAL LOCATION	36
SPREADER BODY	37
10" CHUTE/SPINNER ASSEMBLY	39
15" CHUTE/SPINNER ASSEMBLY	41
CAB CONTROL - GAS SPREADER	43
ON/OFF CONTROL - ELECTRIC SPREADER	44
DUAL VARIABLE CONTROL - ELECTRIC SPREADER.....	45
WIRING HARNESS CONNECTORS	46
NUMERICAL INDEX	47
DEALER CHECKLISTS.....	BACK COVER

INTRODUCTION

This manual was written for the assembly, installation and maintenance of your new Sno-Way® V-BOX GAS AND ELECTRIC SPREADER. Most importantly, this manual provides an operating plan for safe use. Refer to the Table of Contents for an outline of this manual.

Please keep this manual with your machine at all times as reference material and so it can be passed on to the next owner if the machine is sold.

We require that you read and understand the contents of this manual COMPLETELY, especially the chapter on SAFETY, before attempting any procedure contained in this manual.



The Society of Automotive Engineers has adopted this SAFETY ALERT SYMBOL to pinpoint characteristics that, if NOT carefully followed, can create a safety hazard. When you see this symbol in this manual or on the machine itself, BE ALERT!, your personal safety and the safety of others, is involved.

• Defined in the next column, are the SAFETY ALERT messages and how they will appear in this manual.

 WARNING
Information, that if not carefully followed, can cause personal injury or death!

 CAUTION
Information, that if not carefully followed, can cause injury or damage to equipment!

NOTE: Additional information concerning the equipment or the procedure that may or may not be contained elsewhere in this manual.

BE AWARE! It is illegal to remove, deface or otherwise alter the safety decals mounted on this equipment.

Record the Spreader Serial Number and Spreader Model Number, in the space provided below as a handy record for quick reference. The Serial Number is located under the engine cover. This plate contains information that your Dealer needs, to answer questions, to order replacement parts, or to complete warranty work, if needed, for your unit.

NAME PLATE DATA	
SPREADER MODEL NUMBER _____	
SPREADER SERIAL NUMBER _____ <small>(Located under Engine Cover)</small>	
(FILL IN)	

DEALER	
NAME _____	
ADDRESS _____	
CITY _____ STATE _____ ZIP _____	
PHONE (____) - _____	
(FILL IN)	

ORIGINAL PURCHASER	
NAME _____	
ADDRESS _____	
CITY _____ STATE _____ ZIP _____	
PHONE (____) - _____	
(FILL IN)	

We reserve the right to make changes or improve the design or construction of any part(s) without incurring the obligation to install such parts or make any changes on any unit previously delivered.

SAFETY

BEFORE ATTEMPTING ANY PROCEDURE IN THIS BOOK, READ AND UNDERSTAND ALL THE SAFETY INFORMATION CONTAINED IN THIS SECTION. IN ADDITION, ENSURE ALL INDIVIDUALS WORKING WITH YOU ARE ALSO FAMILIAR WITH THESE SAFETY PRECAUTIONS.

For your safety Warning and Information Decals have been placed on this product to remind the operator to take safety precautions. It is important that these decals are in place and are legible before operation begins. New decals can be obtained from Sno-Way or your local dealer.

REMEMBER The careful operator is the best operator. Most accidents are caused by human error. Certain precautions must be observed to prevent the possibility of injury to operator or bystanders and/or damage to equipment.

FIRST TIME OPERATION When running for the first time or after the unit has not been used for a long period of time, run and inspect the conveyor system without spinner and chute assembly attached.

NEVER operate spreader when under the influence of alcohol, drugs or other medications that could hamper your judgement and reactions. An accident may result in serious injury or death to other persons or yourself.

ALWAYS operate vehicle in a well-ventilated area. The carbon monoxide in exhaust gas is highly toxic and can cause injury or death.

NEVER wear wrist watches, rings or other jewelry when working on the vehicle or individual equipment. These things can catch on moving parts or cause an electrical short circuit that could result in personal injury.

ALWAYS wear safety goggles when working on the vehicle to protect your eyes from battery acid, gasoline, and dust or dirt from flying off of moving engine parts.

ALWAYS wear safety glasses with side shields when striking metal against metal! In addition, it is recommended that a softer (non-chipable) metal material be used to cushion the blow. Failure to heed could result in injury to the eye(s) or other parts of the body.

NEVER allow children or unauthorized person to operate this spreader.

NEVER exceed 45 m.p.h. when loaded spreader is attached to vehicle. Braking distances may be increased and handling characteristics may be impaired at speeds above 45 m.p.h.

ALWAYS lock the vehicle when unattended to prevent unauthorized operation.

ALWAYS check the job site for terrain hazards, obstructions and people.

ALWAYS check surrounding area for hazardous obstacles before operating this unit.

ALWAYS make sure personnel are clear of area being spread. Material is discharged from spreader at a high rate of speed and could injure bystanders.

NEVER leave materials in hopper for long periods of time. Remember salt is hygroscopic and will attract enough atmospheric moisture to cause it to “cake”.

NEVER work on the vehicle without having a fully serviced fire extinguisher available. A 5 lb or larger CO² or dry chemical unit specified for gasoline, chemical or electrical fires, is recommended.

NEVER smoke while working on the vehicle. Gasoline and battery acid vapors are extremely flammable and explosive.

ALWAYS make sure that all safety guards are in place before operating the spreader.

ALWAYS shut off the vehicle and spreader engines, place the vehicle transmission in “Park”, turn the vehicle and spreader ignition switches to “OFF” position and firmly apply the parking brake of the vehicle before servicing or making any adjustments to the spreader.

ALWAYS wait for all movement to stop before servicing or adjusting the spreader.

NEVER climb on or allow others to climb on the spreader.

ALWAYS reassemble any parts or hardware removed for cleaning or adjusting before operating the spreader.

ALWAYS remove any tools and other materials from the spreader before operating the spreader

ALWAYS use auxiliary warning lights, except when prohibited by law, when operating the spreader.

NEVER allow hands, hair or clothing to get near any moving part of the spreader. Never wear neckties or loose clothing when working on the spreader or the vehicle.

ALWAYS be aware of and avoid contact with hot surfaces such as engine and exhaust.

ALWAYS inspect the unit periodically for defects. Parts that are broken, missing or plainly worn must be replaced immediately. Never operate the unit when in need of maintenance.

REMEMBER it is the owner’s responsibility for communicating information on the safe use and proper maintenance of this machine.

GENERAL INFORMATION



WARNING

WARNING: Check the vehicle's load rating certification sticker for the maximum vehicle capacity, and **DO NOT** overload beyond the vehicle GVWR or GAWR. Overloading could result in an accident, or damage to the vehicle.

FAILURE TO HEED CAN RESULT IN INJURY OR DEATH.

IMPORTANT: Use of gravel or compactable stone fragments will cause the drive system to jam up. Material should not be left in the hopper overnight because it can become rock solid jamming the spreader drive. Wetted salts when left in a hopper can cause moisture build up on the conveyor chain which can freeze the chain up solid, jamming the spreader drive. If improper materials or improper handling of materials are fed through the spreaders the following will result:

1.) Gasoline Engine Spreaders: Gear Box Failure, Broken Chain, Smoking Clutch.

2.) Electric Spreaders: Constant Circuit Breaker Tripping.

These conditions will not be covered under warranty. Failed Gearboxes, Broken Chains, Smoked Clutches and Burnt Out Electric Motors will not be covered under warranty in such instances

Use the following tables to calculate the vehicle payload whenever you place material in the spreader

CONVEYOR WIDTH	BODY SIDE LENGTH	WIDTH (inches)	HEIGHT (inches)	OVERALL LENGTH (inches)	EMPTY WEIGHT (Lbs.)(No Screen or Battery)	CAPACITY (cubic yd.)	RECOMMENDED USE
10"	5'	39	26	78	468	0.5	SMALL TRUCKS
10"	6'	39	26	91	560	0.75	SMALL TO 1/2 TON TRUCKS
15"	8'	48	27	115	650	1.5	SMALL TO 1/2 TON TRUCKS
15"	8'	48	33	115	760	2.0	FULL SIZE HD TRUCKS
15"	9'	48	33	127	855	3.0	FULL SIZE HD TRUCKS
15"	10'	55	47	139	995	4.0	FULL SIZE HD TRUCKS

Side extensions are not recommended for the S.T. Model Spreader and will void all warranties

MATERIAL WEIGHTS

MATERIAL	LBS. PER CUBIC YD.	LBS. PER CUBIC FT.
# 1 Rock Salt	950	35
# 2 Rock Salt	1,215	45
Coarse Sand - Dry	2,565	95
Coarse Sand - Wet	3,240	120

NOTE: All references to "Left" and "Right" sides relates to equipment as viewed from the rear, and facing the normal direction of vehicle travel.

IMPORTANT: To help prevent a frozen conveyor chain, empty the spreader when not in use

ABBREVIATION KEY

ABBREVIATION KEY							
AR	As Required	CPLG	Coupling	15 Inch Wide	15 Inch Wide Series Spreader	STD	Standard
ASSY	Assembly	ELEC	Electric	REQ	Required	SV	Small V-Box
CB	Carriage Bolt	EV	Electric V-Box	SPKT	Sprocket	V	Standard Larger V-Box
CHMSL	Center High Mounted Stop Lights	HV	Honda Powered V-Box	SS	Stainless Steel	ZP	Zinc Plated
CONV	Conveyer	I.D.	Inside Diameter	10 Inch Wide	10 Inch Wide Series Spreader		

INSTALLATION

Mounting the Spreader Onto the Vehicle

NOTE: Refer to the Repair Parts Diagrams, which are in this manual, to help identify parts referenced in the following text.

1. Remove the tailgate from the truck.
2. Lift the spreader by hooking the loop or hole located on the rear cross channel which is inside the hopper. The loop or hole is located at the approximate balance point of the spreader. The balance point may vary with engine fluid levels, battery, top screen, or any residual material in the hopper.



WARNING

Before lifting, check that the hopper is empty of material. The lifting device must be capable of supporting the spreader's weight. See charts for spreader weights.

FAILURE TO HEED CAN RESULT IN INJURY OR DEATH.

3. Place lengths of lumber under the side ribs of the spreader. By elevating the spreader off the vehicle, it is easier to remove excess material that accumulates under the spreader. Center the spreader on the vehicle with the end of the rails 14" to the rear of the nearest vertical obstruction (e.g., bumper, trailer hitch, etc.).
4. Bolt the spreader to the vehicle frame using the holes located at each lower support leg. Use 1/2" hardware as required by vehicle application.
5. Using the Tie-down Chains, secure the spreader to the vehicle using the tabs located at the corners of the spreader and the vehicle's factory installed anchor points.

NOTE: Check the mounting devices every time the spreader is placed on the truck and loaded with material to make sure they are secure.

Spinner Drive Chain Adjustment

1. Loosely attach the Chute/Spinner Assembly using four 3/8" x 5/8" bolts, lock washers, and nuts, with the head of the bolt on the inside of the chute. Push the Chute/Spinner Assembly toward the front of the vehicle. Do NOT tighten the bolts.

2. Install the Roller Chain between the Spinner Shaft Sprocket and the Gear Case Sprocket. Check that the sprockets are in line. Check the setscrew for tightness. Install the Master Link.

3. To adjust roller chain tension, loosen the Spinner Shaft Bearing Bolts and move the Spinner Shaft away from the Gear Case. Maintain vertical position of the shaft and alignment of sprockets when tightening bearing fasteners. After adjusting, correct chain tension should allow a 5/16" deflection midway between the sprockets. Additional chain tension may be applied by pulling the Chute/Spinner Assembly toward the rear. Tighten all fasteners according to the torque chart on page 21.

4. Install the chain guard using 1/4" x 3/4" long hex cap screws, lock washers, and nuts.

Alignment of Spinner Chute Assembly

1. Remove Chute Pins from Chute.
2. Lift Chute into place so that the LH Hanger Bracket aligns with bracket on the spreader frame. Insert long Chute Pin into left side Chute and spreader brackets.
3. Grease all bearings and especially the hex on the end of the Spinner Shaft.
4. Swing Chute up and check shaft alignment and Latch Pin alignment.
5. Loosen RH Hanger Bracket using a 9/16" wrench.
6. Raise the Chute so that 1/4" or less of the hex shaft is exposed below the coupling. Insert short Chute Pin into the Spreader Frame and RH Hanger Bracket.
7. Tighten the RH Hanger Bracket.

IMPORTANT: If the Spinner Shaft and Coupler still do not align correctly after RH Hanger Bracket adjustment: Adjust the Upper Chute Bearing as necessary, then repeat steps 4-7. Failure to adjust properly will result in excessive Coupler and Spinner Shaft wear. (See Figure 1-1)

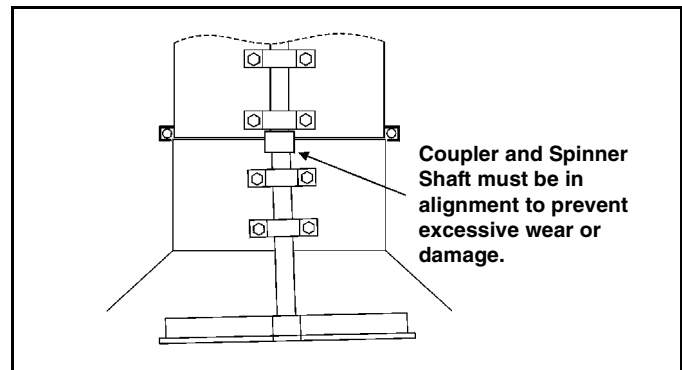

Figure 1-1

Wiring Harness and Cab Control Installation

REMEMBER After the Spreader is installed on the vehicle, the Pre-Delivery Check List and Delivery Check List must be completed.

Tool List

Safety Goggles	12 Volt Test Light
Wire Crimp Tool	Drill
Utility Knife	Drill Bit, 3/8"

Cab Control (Gas Spreader)

1. Attach the Spreader Harness to the side of the spreader using pre-drilled holes and number six clamp loops.

2. Plug the Vehicle Harness into the Spreader Harness.

NOTE: Use Quaker State NYK-77 dielectric grease or equivalent on all electrical connections.

3. Layout the path for vehicle harness through the rear window of vehicle. Unplug harness when not in use and keep in cab until needed.

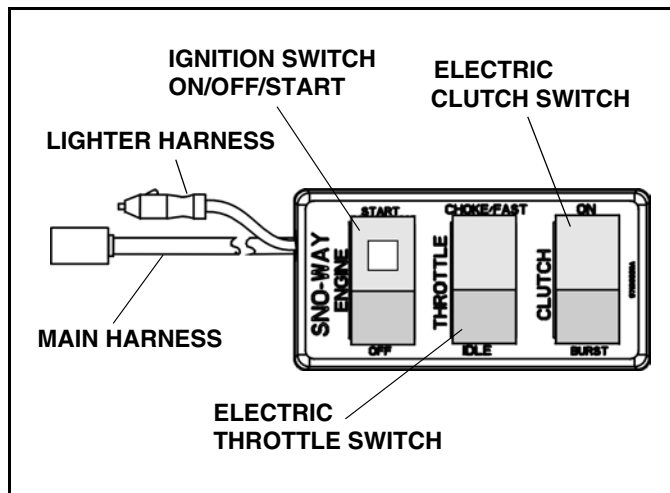

Figure 1-2

4. Mount the Cab Control (See Figure 1-2) in a convenient location. Due to the variety of possible in-cab locations, Velcro® is provided. A suitable bracket should be made and fastened to the cab.

5. Plug cigarette lighter power lead into power outlet in vehicle.

On/Off Control (Electric Spreader)

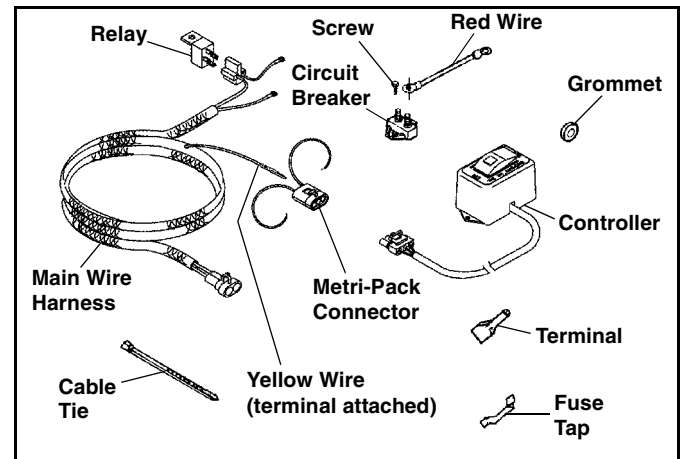

Figure 1-3

1. Locate the following parts:

- Controller
- Wire Harness, Main
- Circuit Breaker
- Fuse Tap
- Terminal, Female
- Grommet
- Neoprene Seal
- Red Wire, Short
- Cable Tie, Plastic
- Self Tapping Screw
- Relay, 70A
- Metri-Pack Connector

(For reference to part numbers, see service parts listing page 44).

NOTE: Take the extra time needed to plan the routing of the wiring harness before drilling any holes or fastening the harness or control box in place. Read all the instructions carefully to ensure all the required conditions are met for a safe and professional installation.

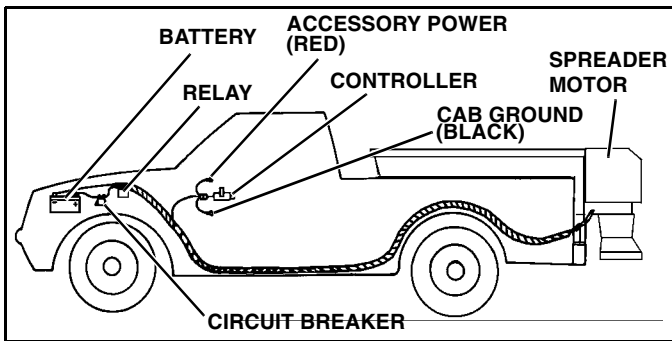



Figure 1-4

2. Uncoil the wiring harness and route the end of the harness with the short red and black wires (with ring terminals installed) from under the vehicle up into the engine compartment on the battery side.

3. Position the red and black wires (with terminals) near the battery and prepare to route the five foot section, with connector, into the vehicle operator compartment area.

4. Look for an existing hole, with rubber grommet, in the vehicle firewall. The hole must be 3/8" or larger.



CAUTION

DO NOT drill any holes until a thorough visual inspection is performed to determine that the area around the hole to be drilled, on both sides of the firewall, is clear of any obstacles such as brake lines, linkage or vehicle wiring.

5. If an existing 3/8" hole is not available, look for an area to drill a 3/8" hole that satisfies these conditions;

- Hole should be drilled on the same side of the vehicle firewall (left or right) as the vehicle battery.
- DO NOT put a hole in such a spot that will force the wiring harness, when installed, to interfere or be routed behind accelerator pedal, brake pedal, clutch pedal, parking brake or associated linkage.
- DO NOT drill any holes until a thorough visual inspection is performed to determine that the area around the hole to be drilled, on both sides of the firewall, is clear of any obstacles such as brake lines, linkage or vehicle wiring.

NOTE: If the hole has to be drilled through carpeting or insulation, reverse the direction of the drill until the carpet has been penetrated, remove the carpet from the hole saw then use the forward direction to continue drilling through the firewall, this should prevent "running" in the carpet.

6. Using a drill, make a 3/8" hole through the vehicle firewall.



CAUTION

Keep wiring harness away from moving parts, sharp edges and areas of extreme heat to avoid electrical failure and fire.

7. Install the grommet into the firewall.

8. Feed the yellow wire (with connector terminal attached) through the grommet into the cab.

9. Inside the cab, insert the terminal on the yellow wire into the vacant slot in the back of the three-wire connector that has red and black wire leads already installed. Push the terminal fully into the connector until it locks in place.



WARNING

Mount the control box in an area that will not interfere with the legs during seat travel and that will not allow the knees to come in contact with it in an accident.

FAILURE TO HEED CAN RESULT IN INJURY OR DEATH.

10. Use hook and loop strips (Velcro®) to mount the control in an appropriate location.

11. Connect the vehicle harness, inside the cab, to the control box connector.

12. Remove the accessory fuse from the vehicle fuse box.

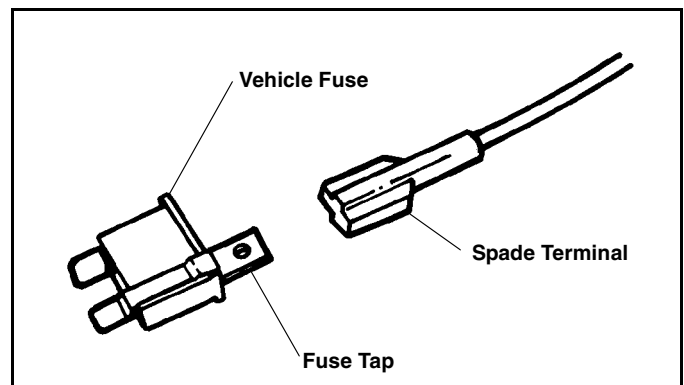

Figure 1-5

13. Using a test probe, determine the fused “Dead/OFF” side of the fuse and attach the A.T.O. fuse tap to that side of the fuse. (See Figure 1-5).

NOTE: Two fuse tap-ins are provided, one for standard (ATO/ATC) automotive blade fuses and one for mini-blade automotive fuses. Determine which type of fuse the vehicle uses. If the standard fuse is used, the fuse tap-in will require the provided 1/4” female spade terminal, if the mini-fuse is used, the fuse tap-in will require the provided 3/16” female spade terminal.

IMPORTANT: DO NOT use fuse designated for head lamp, tail lamp, stop lights, panel lights, or other critical fuses.

NOTE: If accessory fuse is not available in the fuse box use another fuse with a 10-15 amp designation, i.e. radio, lighter, etc.

14. Cut end of “Red” wire to length, strip end and install the appropriate female spade terminal onto wire.

15. Attach female spade terminal to appropriate fuse tap-in and re-install fuse.

IMPORTANT: The RED wire must be protected by a fuse. If it is not practical to attach this wire to a fused circuit in the vehicle fuse box an in line 10 amp fuse must be added to this wire.

16. Attach the controller ground wire (black with ring terminal) to a grounding point inside the vehicle cab.

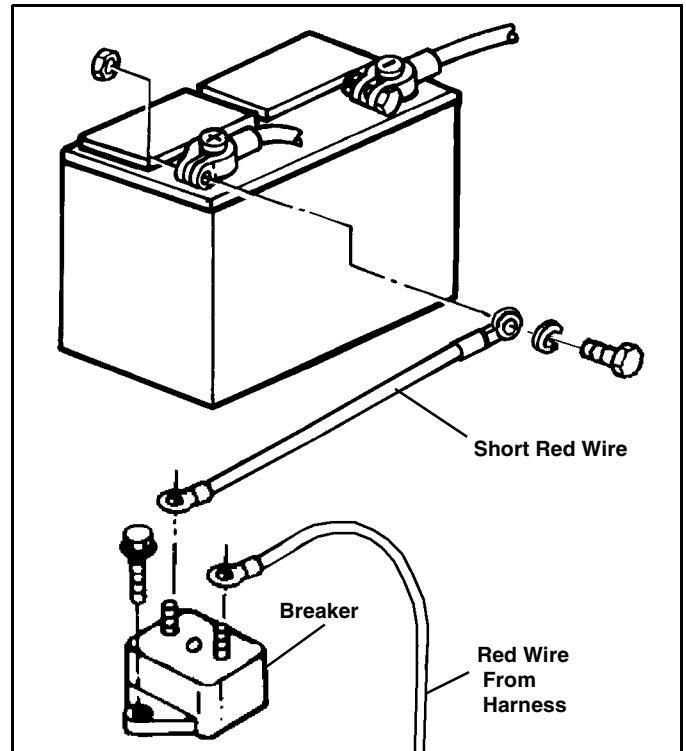

Figure 1-6

17. Locate short red wire (#96106728) with two ring terminals. Attach the small ring terminal to the copper colored post marked BAT on the breaker. Attach the other, large ring terminal to the battery positive terminal. (See Figure 1-6).

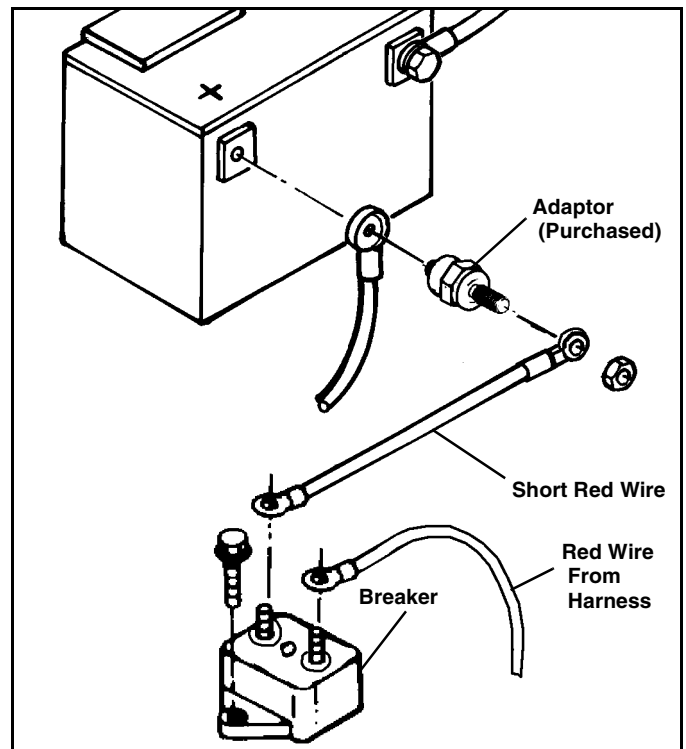



Figure 1-7

 **WARNING**

Disconnect vehicle NEG. (-) battery cable while performing Steps 17-24 to avoid serious bodily injury from fire or explosion.

FAILURE TO HEED CAN RESULT IN INJURY OR DEATH.

NOTE: If the vehicle has a "side post" battery, it will be necessary to install adaptors (#96100773) to make connections at the vehicle battery (See Figure 1-7).

IMPORTANT: The circuit breaker must be placed in a location that will avoid excessive heat. DO NOT locate these parts near the engine exhaust manifold. A preferred location is one that will receive good air flow from the radiator fan, but be protected from excessive engine heat.

18. Mount the circuit breaker with two (2) #10 x 1" self-tapping screws (#98100037).

19. Assemble the relay (from the bag of parts) onto the relay connector plug on the main wire harness. Mount the relay, using the mounting tab on the relay and a #10 x 1" self-tapping screw (#98100037) near the circuit breaker in a location that will avoid excessive heat.

20. Attach the ring terminal of the positive (RED) wire of the wiring harness to the other terminal of the circuit breaker.

21. Attach the black harness negative wire to the vehicle battery NEG (-) post.

Dual Variable Speed Control (Electric Spreader)

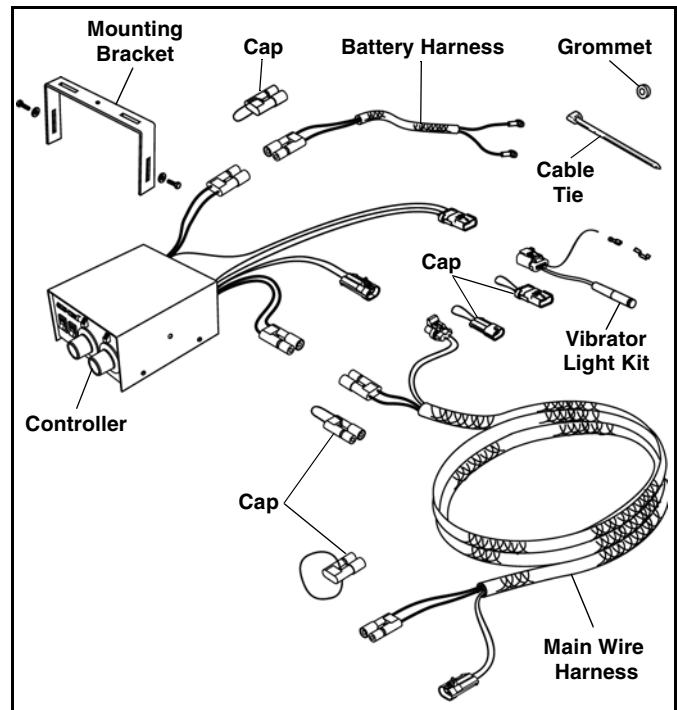

Figure 1-8

1. Locate the following parts:

- Controller
- Mounting Bracket
- Wire Harness, Main
- Wire Harness, Battery
- Grommet
- Cable Tie, Plastic
- Vibrator Light Kit
- Cap Covers

(For reference to part numbers, see service parts listing page 45).

**CAUTION**

Keep wiring harness away from moving parts, sharp edges and areas of extreme heat to avoid electrical failure and fire.

22. Route vehicle harness from engine compartment to rear bumper by the hitch receiver tube. Attach the harness assembly to the vehicle at different points in the cab and engine compartment and frame that will not allow the harness to come in contact with sharp edges, hot components and moving parts or mechanisms. Be sure the harness is supported and protected by the vehicle frame.

23. Fasten the main harness to the rear of the vehicle near the bumper. Leave enough slack in the harness so that the motor harness from the spreader can be connected easily and not be under tension.

24. Connect the motor harness from the spreader to the main wire harness.

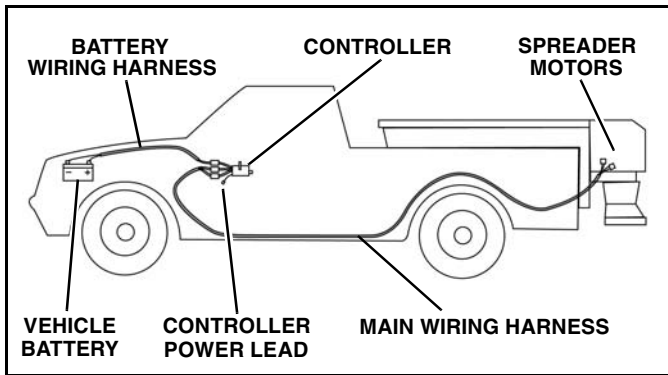



Figure 1-9

NOTE: Take the extra time needed to plan the routing of the wiring harness before drilling any holes or fastening the harness or control box in place. Read all the instructions carefully to ensure all the required conditions are met for a safe and professional installation. (See Figure 1-9).

2. Look for an existing hole, with rubber grommet, in the vehicle firewall. The hole must be 1.0" or larger.



CAUTION

DO NOT drill any holes until a thorough visual inspection is performed to determine that the area around the hole to be drilled, on both sides of the firewall, is clear of any obstacles such as brake lines, linkage or vehicle wiring.

3. If an existing 1.0" hole is not available, look for an area to drill a 1.0" hole that satisfies these conditions;

- Hole should be drilled on the same side of the vehicle firewall (left or right) as the vehicle battery.
- DO NOT put a hole in such a spot that will force the wiring harness, when installed, to interfere or be routed behind accelerator pedal, brake pedal, clutch pedal, parking brake or associated linkage.
- DO NOT drill any holes until a thorough visual inspection is performed to determine that the area around the hole to be drilled, on both sides of the firewall, is clear of any obstacles such as brake lines, linkage or vehicle wiring.

NOTE: If the hole has to be drilled through carpeting or insulation, reverse the direction of the drill until the carpet has been penetrated, remove the carpet from the hole saw then use the forward direction to continue drilling through the firewall, this should prevent "running" in the carpet.

4. Using a drill, make a 1.0" hole through the vehicle firewall.

5. Install the grommet into the firewall.



CAUTION

Keep wiring harness away from moving parts, sharp edges and areas of extreme heat to avoid electrical failure and fire.

6. Uncoil the battery wiring harness and route the end of the harness with the short red and black wires (with ring terminals installed) through the grommet and into the engine compartment. Position the red and black wires (with terminals) near the battery.

7. Uncoil the main wiring harness and route from the vehicle interior, through the grommet, to the rear bumper by the hitch receiver tube. Attach the harness assembly to the vehicle at different points in the cab interior, engine compartment and frame that will not allow the harness to come in contact with sharp edges, hot components and moving parts or mechanisms. Be sure the harness is supported and protected by the vehicle frame.

8. Fasten the main harness to the rear of the vehicle near the bumper. Leave enough slack in the harness so that the motor harness from the spreader can be connected easily and not be under tension.

9. Connect the motor harnesses from the spreader to the main wire harness.



WARNING

Mount the control box in an area that will not interfere with the legs during seat travel and that will not allow the knees to come in contact with it in an accident.

FAILURE TO HEED CAN RESULT IN INJURY OR DEATH.

10. Position the controller mounting bracket in the vehicle in a suitable location. Using appropriate hardware (not provided), secure the mounting bracket to the vehicle.

11. Position the controller in the mounting bracket and secure with two flat washers and cap screws.
12. Ensure that both power switches on the controller are in the **OFF** position.
13. Connect the battery, main wiring harness and vibrator light kit connectors to the appropriate controller connectors inside the cab.
14. Route the RED/WHITE wire from the main harness vibrator light kit connector to the vehicle fuse block.

IMPORTANT: The RED/WHITE wire must be protected by a fuse. In the steps that follow, this wire is connected to an existing fuse in the vehicle fuse box. If it is not practical to attach this wire to an existing fused circuit in the fuse box, install an in-line 10 amp fuse to this wire before it is connected to another 12VDC source. The 12VDC source must be a stand-alone circuit that is powered only when the ignition is activated. Do not connect it to a vehicle fan circuit, as voltage may drop below 10VDC during fan operation and cause the controller to fault.

15. Locate the accessory fuse in the fuse box. Remove the fuse and using a test probe, determine the "Dead/OFF" side of the fuse.

NOTE: If an accessory fuse is not available in the fuse box, use another fuse with a 10-15 amp designation (i.e. radio, lighter, etc).

WARNING

Disconnect vehicle NEG. (-) battery cable while performing the following steps to avoid serious bodily injury from fire or explosion.

FAILURE TO HEED CAN RESULT IN INJURY OR DEATH.

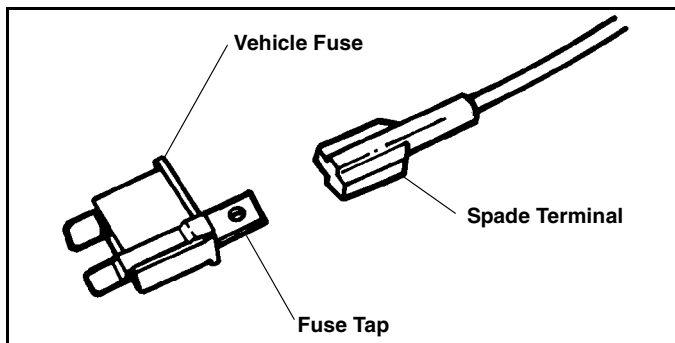

Figure 1-10

NOTE: Two fuse tap-ins are provided, one for standard (ATO/ATC) automotive blade fuses and one for mini-blade automotive fuses. Determine which type of fuse the vehicle uses.

• If a standard fuse is used, the fuse tap-in required is the provided 1/4" female spade terminal (#96002083).

• If a mini-fuse is used, the fuse tap-in required is the provided 3/16" female spade terminal (# 96101832).

16. Attach the appropriate fuse tap (ATC/ATO or Mini Fuse) to that "Dead/OFF" side of the fuse. (See Figure 1-10).

17. Trim the RED/WHITE wire (from the main harness vibrator light kit connector) to the length required, and install a 1/4" Female Blade Connector on the end. Attach the blade connector to the fuse tap, and insert the fuse in the fuse box, ensuring the "Dead/OFF" side of the fuse is properly indexed.

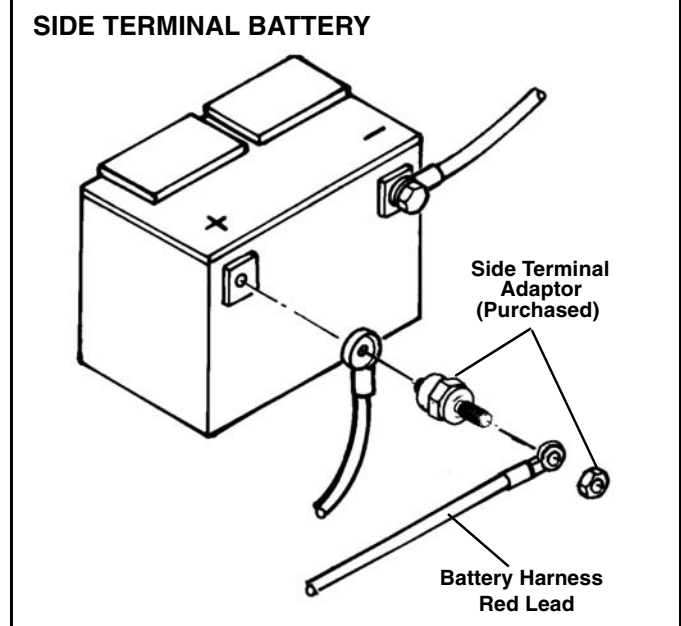
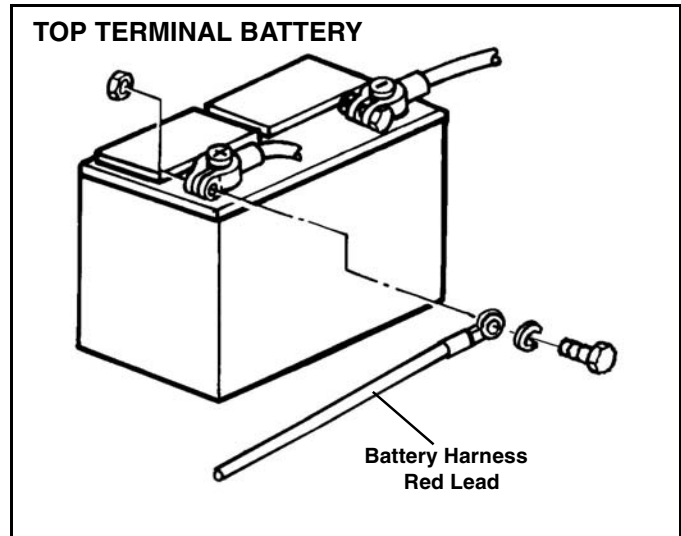

Figure 1-11

18. Attach the ring terminal of the spreader positive (RED) battery harness wire to the vehicle battery POSITIVE (+) post (See Figure 1-11).

NOTE: If the vehicle has a side terminal (side post) battery, it will be necessary to install adaptors (#96100773) to make connections at the vehicle battery.

19. Connect the vehicle NEG. (-) battery cable to the battery.

20. Attach the ring terminal of the spreader negative (BLACK) battery harness wire to the vehicle battery NEGATIVE (-) post.

Battery Safety



WARNING

- **Never lay tools or equipment on the battery. You could accidentally ground the POSITIVE (+) battery terminal, resulting in electrical shock, burns or damage to equipment.**
- **Always disconnect the battery before removing or replacing electrical components such as the starter relay or battery cables.**

**FAILURE TO HEED CAN RESULT IN INJURY
OR DEATH.**

OPERATION

Gas Spreader - Electric Control Operation

Gas Spreaders - Electric Throttle

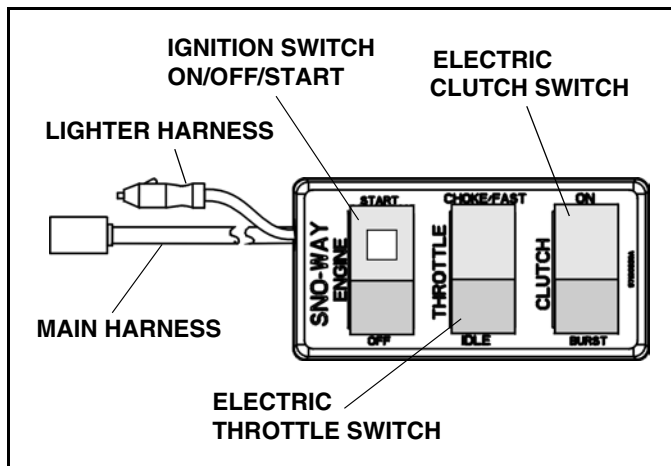

Figure 2-1

NOTE: The conveyor and spinner will operate when the clutch switch is in the ON or BURST position.

Starting the Engine

Gas Spreaders - Electric Throttle

1. Verify that the clutch switch is "OFF".
2. Depress the throttle switch to "IDLE" and hold for two seconds; release.
3. Depress the ignition switch to "START".
4. While the engine is cranking, depress the throttle switch to "Choke/Fast" for 5 seconds, then release switch. That will ensure that the choke is fully engaged. This is necessary for cold starting.
5. When the engine starts to fire, tap the "IDLE" side of the throttle switch once or twice to open choke. This will allow more air to the carburetor, and the engine will run smoother.
6. To control engine speed, after starting:
 - To increase the engine speed, tap the "CHOKE/FAST" side of the throttle switch. **Be careful not to engage choke. Warm engine will run rough and emit black smoke if choke is engaged.**
 - To decrease the engine speed, tap the "IDLE" side of the throttle switch.
7. If the engine does not start after 20 seconds of cranking:
 - Depress ignition switch to "OFF" and unplug cigarette adapter.
 - Check fuel level.

- Ensure that fuel shut-off is in "ON" position.
- If engine still fails to start, see engine owner's manual, shipped with spreader.

Stopping the Engine

Depress the spreader ignition switch to "OFF".

Clutch Operation

1. Start the engine and adjust the speed to slightly above idle.
2. Depress the clutch switch to "ON".
3. Increase the engine speed to the desired RPM.

IMPORTANT:

- To help prevent a frozen conveyor chain, empty the spreader when not in use.
- If the Conveyor Chain becomes "stuck" or "frozen", remove the material from the hopper and free the chain, or move the spreader to a warm area to thaw the material.
- Do not attempt to free the chain by using a pipe wrench or any other tool on the output shaft of the gear case. The gear case is designed to accept torque from the output shaft only. Attempts to turn the output shaft will strip the gears and void any warranty.
- Excessive engine speed, and sudden clutch engagement, may cause damage to spreader. (See Figure 2-2).

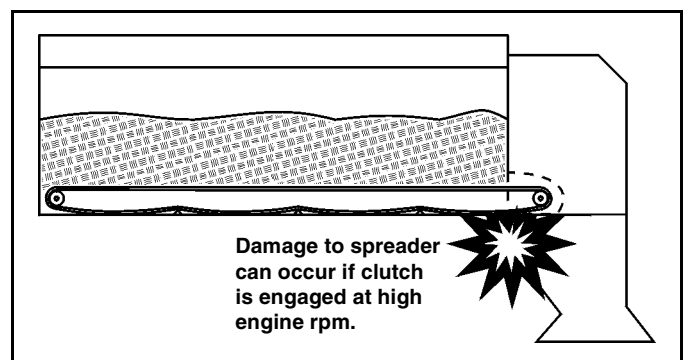

Figure 2-2

The electric clutch can be engaged or disengaged at any time, and at any engine RPM. However, since engagement time and thus torque are almost instantaneous, it is recommended that the electric clutch be engaged at the lowest possible RPM without stopping the engine. This will prevent premature spinner chain failure and chain tension loss.

Shield Adjustment

Spread pattern, and the amount of material dispensed, depends on engine RPM, gate position, and shield settings.

- *Decreasing* RPM, and/or gate-opening, will *decrease* the amount of material coming to the spinner.
- *Increasing* RPM, and/or gate opening, will *increase* the amount of material coming to the spinner.

External Shield Configuration

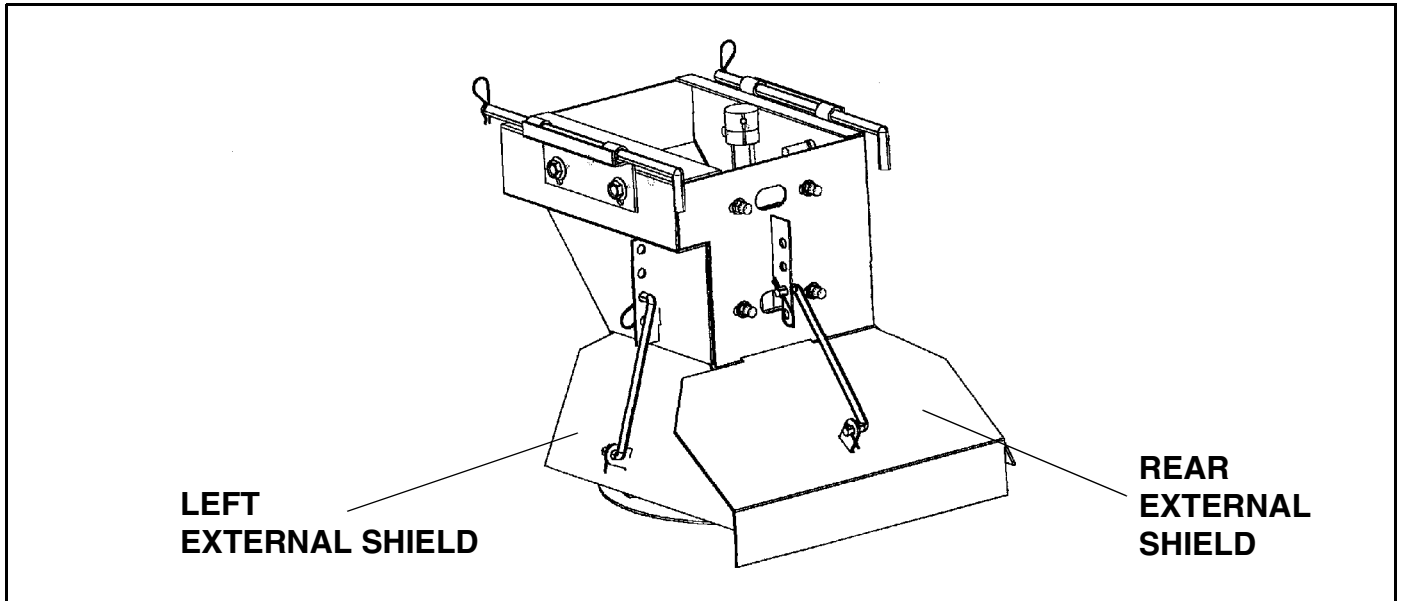

Figure 2-3

External Shield Adjustment

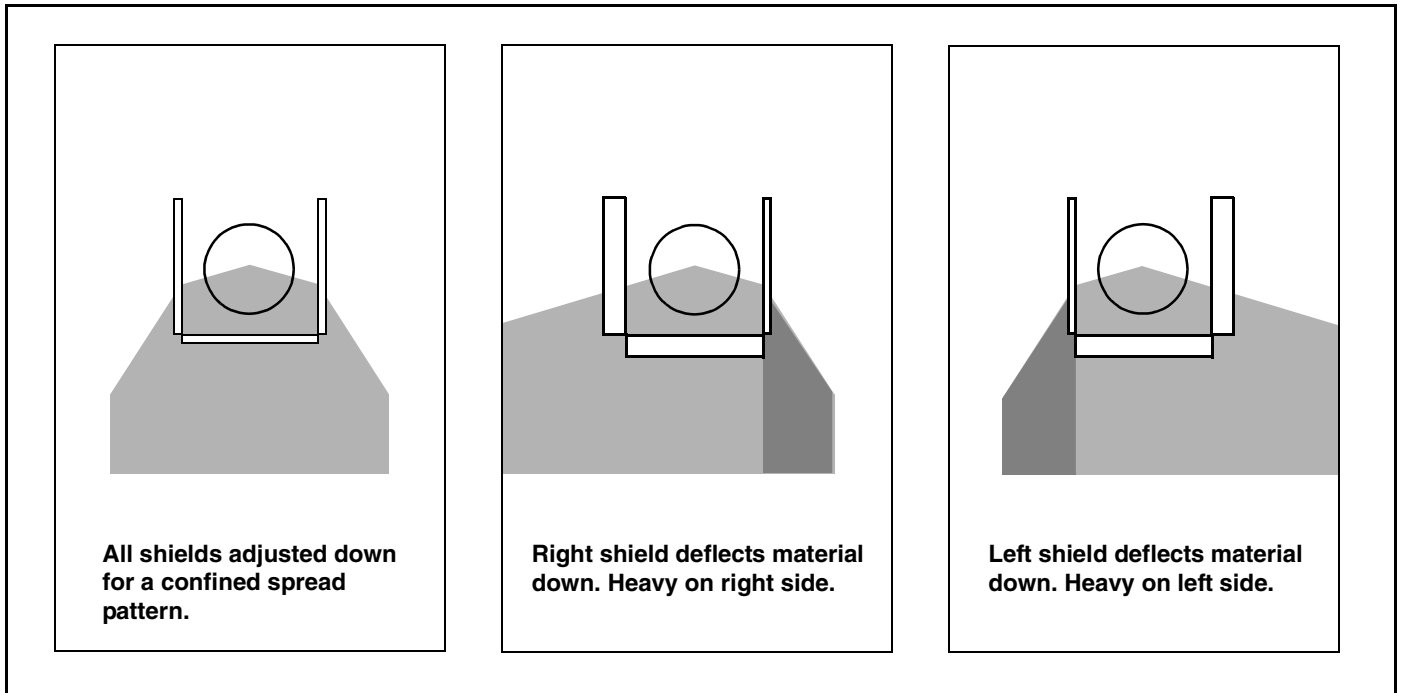

Figure 2-4

Electric Spreader - On/Off Control Operation



CAUTION

The controller input voltage must be a minimum of 11 volts DC for proper operation. Be sure the vehicle battery and alternator are in good operating condition and adequate to provide 11 volts DC to the salt spreader controller.

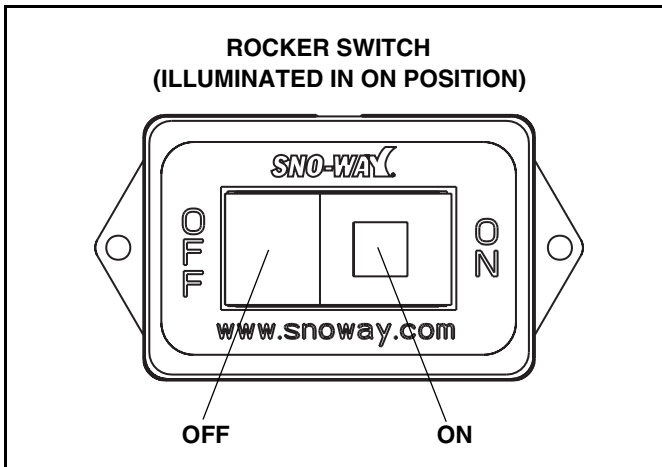

Figure 2-5

The following control and indicator is located on the face of the control box (See Figure 2-5):

- Illuminating ON/OFF rocker switch—used to start or stop spinner motor. Switch is an illuminating, rocker type switch.

The motor controller controls the speed of the spinner drive motor by supplying set voltage and current to the spinner drive motor.

Current is supplied by a control power lead (RED wire) from the vehicle fuse block and must be protected by a fuse no greater than 15 amps. This control power lead must also be connected to the fuse block so that the controller receives current **ONLY** when the vehicle ignition is in the ACC position or RUN position. (See "On/Off Control (Electric Spreader)" on page 6.)

The spinner drive motor is protected by a 40 amp circuit breaker installed in the wiring system near the vehicle battery.

Start:

The ON/OFF switch on the front of the control box is an illuminating rocker switch. When the ON side of the switch is depressed, current will be directed to the spinner drive motor and the indicator light behind the rocker switch will illuminate to indicate that power is ON to the spinner drive motor. Also, when the ON switch is depressed, the motor control will go to FULL.



WARNING

Make sure that the vehicle ignition switch is in the OFF position and key removed from the switch before inspecting the Spreader for cause of obstruction.

FAILURE TO HEED CAN RESULT IN INJURY OR DEATH.

If the spinner drive motor stalls, press the OFF side of the ON/OFF switch to shut off the power to the spinner drive motor. Turn off the vehicle ignition and remove the key from the ignition switch. Inspect the hopper and the spinner drive to determine the cause of the obstruction.

Correct the problem and test to make sure everything is clear, then restart the spinner drive motor.

Disconnect Protection:

The ground wire to the controller circuit must be connected to a good ground on the vehicle to insure proper controller function. In case the control ground is lost, by a disconnected ground wire or poor/improper ground, the controller will automatically shut down. If the ON/OFF switch is depressed (ON) and the switch **DOES NOT** illuminate, it will indicate an improper ground to the controller.

Ignition Switch Shutoff Procedures:

If the vehicle ignition switch is turned OFF while the spreader control is in the ON position, the spinner drive will shut off. When the vehicle ignition switch is then turned ON, the spreader control switch must be manually depressed to the ON position to restart the spinner drive.

MOTOR DUTY CYCLE:

Motor is not a continuous duty cycle motor. If the motor becomes hot to the touch, the motor is approaching heat limits. Be sure to allow adequate cooling of motor before using the spreader again.

Electric Spreader - Dual Variable Control Operation



CAUTION

The controller input voltage must be a minimum of 11 volts DC for proper operation. Be sure the vehicle battery and alternator are in good operating condition and adequate to provide 11 volts DC to the salt spreader controller.

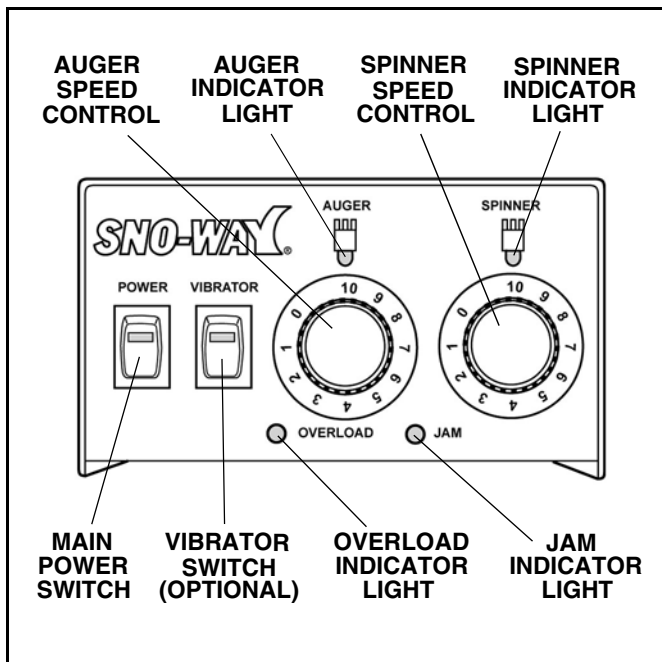

Figure 2-6

The following controls and indicators are located on the face of the controller (See Figure 2-6):

- Illuminating main power rocker switch—used to start or stop spinner and auger motors (and the optional vibrator motor if equipped).
- Illuminating vibrator motor rocker switch—used to start or stop the optional vibrator motor.
- Spinner speed control and indicator light - the dial is used to adjust the speed of the spinner. The indicator provides dial illumination.
- Auger speed control and indicator light - the dial is used to adjust the speed of the auger. The indicator light provides dial illumination.
- Overload indicator light - This light will illuminate when the auger experiences excessive forces due to material blockage or freezing.
- Jam indicator light - This light will illuminate when the auger can no longer turn.

The motor controller controls the speed of the spinner and conveyor drive motors by supplying a variable voltage and current to the motors, as determined by their respective speed control settings.

Current is supplied by a control power lead (RED wire) from the vehicle fuse block and must be protected by a fuse no greater than 15 amps. This control power lead must also be connected to the fuse block so that the controller receives current **ONLY** when the vehicle ignition is in the ACC position or RUN position. (See "Dual Variable Speed Control (Electric Spreader)" on page 9.)

The spinner and conveyor drive motors are protected by internal circuit breakers in the controller.

Start

The POWER switch on the front of the controller is an illuminating rocker switch. When the ON side of the switch is depressed, current will be directed to the auger and spinner drive motors and the indicator light behind the rocker switch will illuminate to indicate that power is ON.

Adjust the speed of the auger and spinner motors as desired.



WARNING

Make sure that the vehicle ignition switch is in the OFF position and key removed from the switch before inspecting the Spreader for cause of obstruction.

FAILURE TO HEED CAN RESULT IN INJURY OR DEATH.

If either drive motor stalls, press the OFF side of the ON/OFF switch to shut off the power to the drive motors. Turn off the vehicle ignition and remove the key from the ignition switch. Inspect the hopper and the spinner drives to determine the cause of the obstruction.

Correct the problem and test to make sure everything is clear, then restart the drive motors.

Ignition Switch Shutoff Procedures:

If the vehicle ignition switch is turned OFF while the spreader control power switch is in the ON position, the spinner and conveyor drive will shut off. When the vehicle ignition switch is then turned ON, the spreader control power switch must be manually depressed to the ON position to restart the spinner drive.

MOTOR DUTY CYCLE:

Motors are not continuous duty cycle motors. If a motor becomes hot to the touch, the motor is approaching heat limits. Be sure to allow adequate cooling of motor before using the spreader again.

MAINTENANCE

General

- Use Quaker State NYK-77 dielectric grease, PN3329 or an equivalent grease, on all electrical connections at the beginning and end of each season, and as required during the season.
- Grease the idler bearings on the Idler Shaft, flanged bearings on the Drag Shaft, and spinner shaft bearings every 10 hours of operation.
- Grease the input shaft bearing on the Gear Case every 50 hours of operation.

NOTE: Over-greasing may cause seal damage. The Gear Case must be filled to the oil level plug with SAE 90 gear-type lubricant. Keep the breather plug clean.

- Check the Conveyor Chain slack periodically. Check the tension by measuring the distance between the end of the rear rail and the point where the chain contacts the lower flange on the rail. The correct distance for adjustment is 26" to 30". (See Figure 3-1).

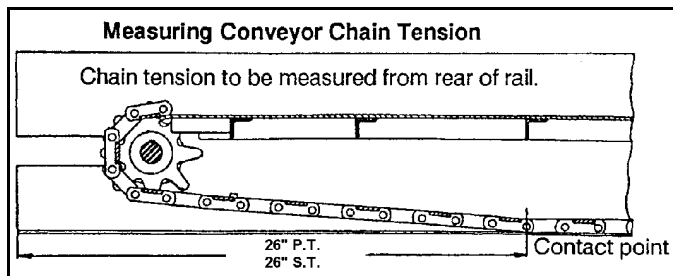

Figure 3-1

- Maintain engine-to-gear case roller chain tension. Correct chain tension allows 5/16" deflection mid-way between the sprockets. Oil this chain often, and at the end of each season.
- Maintain spinner shaft-to-gear case roller tension. Correct chain tension allows 5/16" deflection mid-way between the sprockets. To increase chain tension, loosen the bearing mounting hardware and adjust chain tension with 5/16" adjusting bolts. After adjusting, re-tighten bearing hardware. Make sure the Spinner Shaft is vertical and the sprockets are in line before re-tightening the fasteners. Oil this chain often, and at the end of the season.

NOTE: Over-tightening the roller chains may damage the bearings on the Gear Case, the engine, and the Spinner Shaft. Over-tightening will also shorten the life of the roller chain and of the sprockets.

- Empty the spreader when it is not in use to prevent frozen conveyor chain.
- Wash out the spreader when it is not in use. At the end of the season, oil or paint all bare surfaces after washing and prior to storing the unit.

- To minimize problems and extend the life of the Electric Clutch, the following procedures are recommended:
 - At the end of each snow season, remove and clean the clutch.
 - After cleaning the clutch, coat both mating surfaces of the clutch with oil or light grease.
 - Remove oil and grease prior to using the clutch again.

Engine Service and Repair

Maintain the spreader engine according to the engine owner's manual which is shipped with the spreader. Engine warranty is covered by the engine manufacturer and is described in the back of the engine owner's manual.

If service or repair is needed, contact an authorized Service Center for the manufacturer of your engine. To serve you promptly, the Service Center will need the model, type, and code number for your engine. Your nearest service center is listed in the "Yellow Pages" under "Engines, Gasoline" or "Gasoline Engines."

Electric Throttle Replacement

Removal

1. Carefully observe the existing installation. Mark the bracket position on the Engine Mount.
2. Disconnect the electric wires.
3. Remove 1/4-20 fasteners holding the Electric Throttle Bracket to the Engine Mount.
4. Remove the 6-32 fasteners holding the Electric Throttle Motor to the bracket. Remove the motor.

Installation

1. Connect the electric wires matching colors, brown to brown, red to red.
2. Using the Electric Throttle Control, run the new motor until the crank reaches the 12 o'clock position. A 9-volt battery can be a substitute for the control.
3. Fasten the Electric Throttle Motor to the bracket using the existing hardware.
4. Using the Electric Throttle Control, run the new Electric Throttle Motor until the Crank is against the bracket as shown in the parts diagram. (See "ELECTRIC THROTTLE" on page 35).
5. Place the Electric Throttle Arm on the Crank as shown in the parts diagram. (See "ELECTRIC THROTTLE" on page 35.)

6. Place the Electric Throttle Assembly onto the Engine Mount inserting the Throttle Pin into the engine choke/throttle linkage plastic slider.

7. Loosely bolt the Electric Throttle Assembly to the Engine Mount with the existing hardware.

8. Keeping the Electric Throttle Arm parallel to and against the carburetor, move the Electric Throttle Bracket forward putting the engine throttle into the full choke position. Tighten the fasteners according to the torque chart on page 21.

9. Check that the crank is stopped in both directions by the bracket, not the carburetor linkage.

Dual Electric Controller Error Codes

The controller internal diagnostics will turn an ERROR LED on and flash a sequence of lights on the FLASH NUMBER LED when a fault is detected in the system.

Record the number of flashes on the FLASH NUMBER LED, then refer to the Error Code Chart below to determine the problem and suggested resolution.

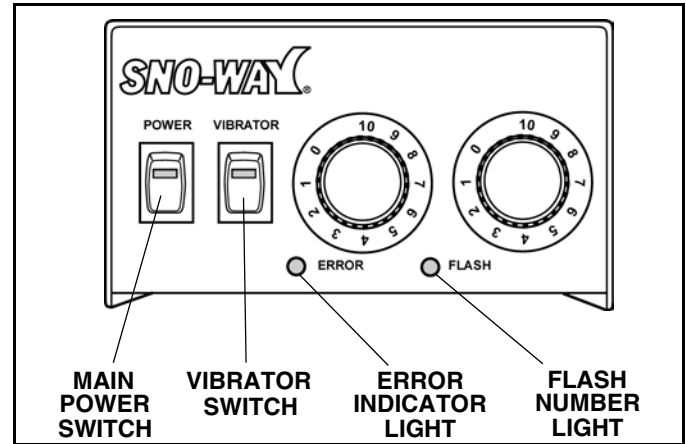

Figure 3-2

Controller Error Code Chart

ERROR LED	FLASH NUMBER LED	PROBLEM	RESOLUTION
OFF	OFF	No Problems. No Errors.	Normal state of controller
ON	OFF	Motor Overload	An electrical overload has occurred in either the AUGER or SPINNER motor. The controller is attempting to eliminate the jam the appropriate motor and will turn off the ERROR LED if successful.
ON	1 Flash	Low Battery Voltage	The controller input voltage has been measured at less than 10 volts. Check the controller input connection and the vehicle battery voltage.
ON	2 Flashes	Blown Fuse	One of the internal controller fuses has failed after power was applied. If the AUGER dial light is off, replace the AUGER fuse. If the SPINNER dial light is off, replace the SPINNER fuse. If, when the VIBRATOR switch is turned on, the VIBRATOR switch LED is off, replace the VIBRATOR fuse.
ON	3 Flashes	Disconnected Motor	Either the AUGER, SPINNER or VIBRATOR motor was disconnected from the controller when power was first applied. Check the cable harness or motors for disconnection.
ON	4 Flashes	Overloaded Spinner Motor	The SPINNER motor is continuously drawing greater than 30 Amps of current, and controller cannot free the jam using 50 Amps of current. Turn off the controller and physically check that the SPINNER motor is not jammed.
ON	5 Flashes	Overloaded Auger Motor	The AUGER motor is continuously drawing greater than 52 Amps of current, and controller cannot free the jam using the AUTO-REVERSE feature and 70 Amps of current. Turn off the controller and physically check that the AUGER motor is not jammed.

ERROR LED	FLASH NUMBER LED	PROBLEM	RESOLUTION
ON	6 Flashes	External Short Circuit To Ground	After power was first applied to the controller, a short circuit to ground was detected in one of the 12VDC wires leaving the controller. The short is either in the AUGER WHITE 12VDC wire to ground or the GREEN SPINNER GREEN 12VDC wire to ground. Turn off the controller. Disconnect the controller from the motor cable harness then turn the controller on again. If the ERROR clears, the short is in the cable harness. If the ERROR does not clear, the controller is at fault and needs to be replaced.
ON	7 Flashes	Missing Battery Voltage	The controller input voltage on the RED 10 AWG wire has been measured at less than 5 volts after power was first applied to the controller. Check the controller input connection for low voltage or for a poor power connection. The controller does require a minimum of 8 VDC to operate.

Metri-Pack™ Connector Repair

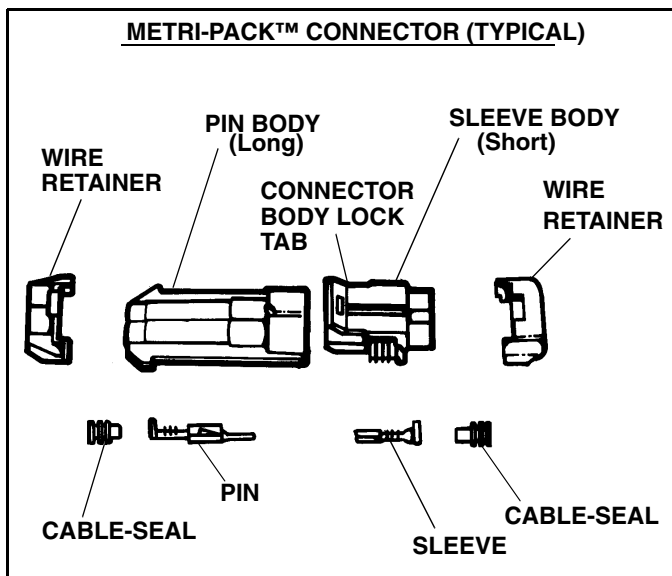

Figure 3-3

IMPORTANT: Identify wire number/color locations with connector terminal letters before disassembly.

Terminal Removal

1. Lift connector body lock tab and pull to separate connector halves.
2. Remove wire retainer on sleeve body or pin body, as necessary, with a screwdriver and save for re-use (See Figure 3-4).

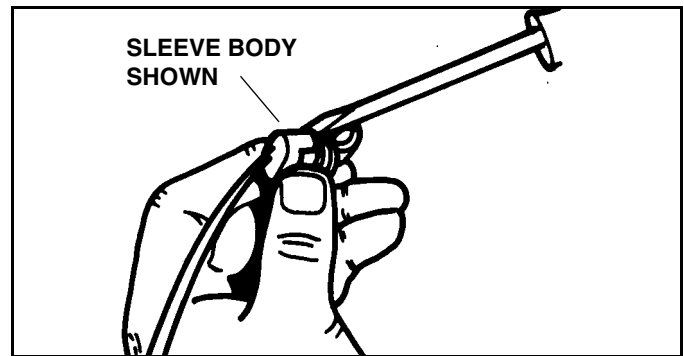

Figure 3-4

3. Push wire into connector as far as possible to release pressure on terminal locking tang.

4. Locate the terminal lock tang in the connector cavity by looking into the connector from the mating end. Use Terminal Removal Tool (#96102499) to depress the lock tang and gently pull wire to remove wire and terminal from connector body. (See Figure 3-5).

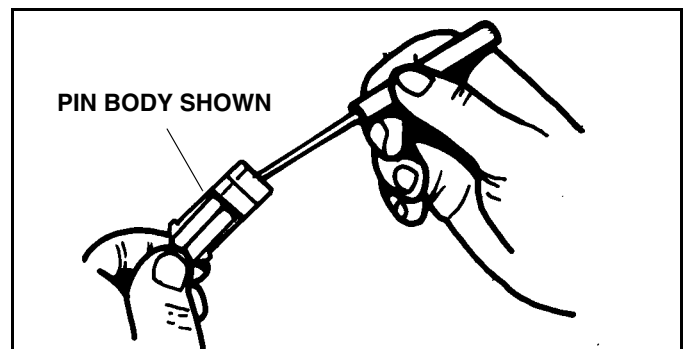

Figure 3-5

5. Locate the terminal lock tang in the connector cavity by looking into the connector from the mating end. Use Terminal Removal Tool (#96102499) to depress the lock tang and gently pull wire to remove wire and terminal from connector body. (See Figure 3-5).

Terminal Replacement

1. Cut wire as close as possible to old terminal and remove old cable seal. (See Figure 3-6).

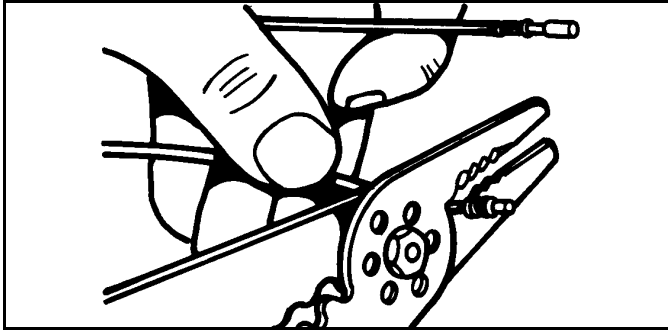

Figure 3-6

IMPORTANT: METRI PACK™ connectors are keyed A, B, C, etc. for proper contact mating. Be sure contacts and wire colors/numbers match and are in proper alignment.

2. Install new correct size cable seal on wire (See Figure 3-7).

Cable seals are available for three sizes of wire:

- Large - 1.0 mm (16 gauge) wire
- Medium - 0.8 mm (18 gauge) wire
- Small - 0.5 mm (20 gauge) wire

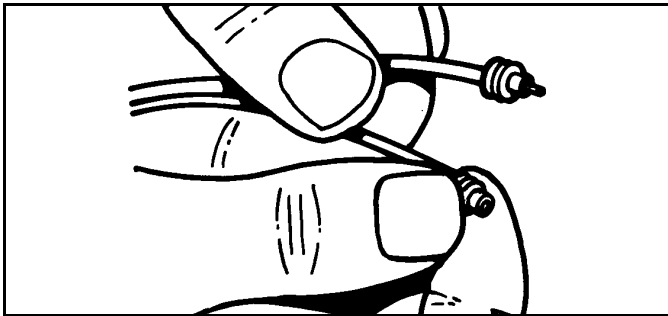

Figure 3-7

3. Strip insulation from wire to expose 6mm (1/4 in) and align cable seal with edge of insulation (See Figure 3-8).

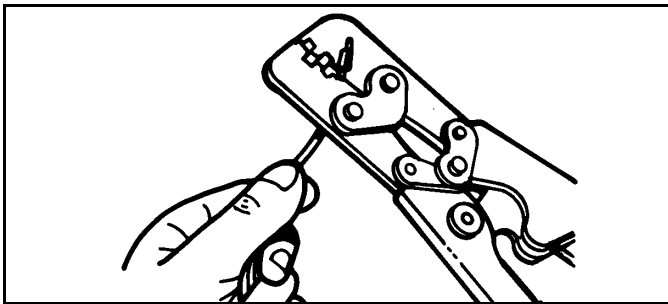

Figure 3-8

4. Place appropriate terminal on wire and use Crimper (#96102500) to secure contact in place with a "W" type crimp.

5. Use Crimper to secure cable seal to terminal.

IMPORTANT: Proper barb location and orientation for installation of sleeve and pin is shown (See Figure 3-9).

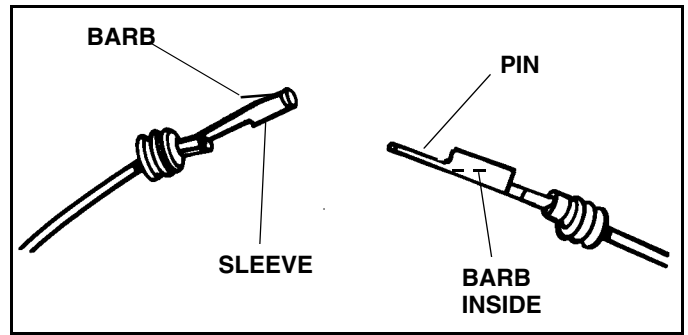

Figure 3-9

NOTE: Connector bodies are keyed for proper terminal mating. Be sure terminals are in proper alignment.

6. Push new terminal into connector body until fully seated (See Figure 3-10).

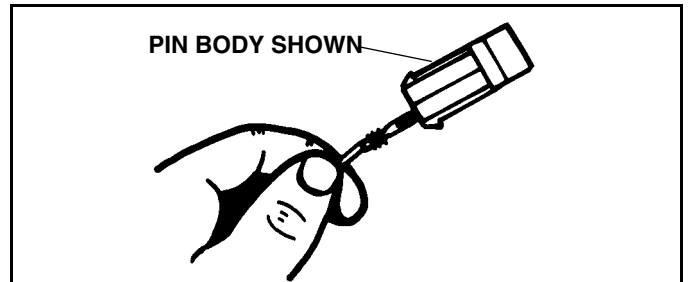

Figure 3-10

7. Pull on wire slightly to be certain terminal is locked in place.

8. Install wire retainer.

9. Repeat as necessary to replace other terminals.

10. Close connector body (See Figure 3-11).

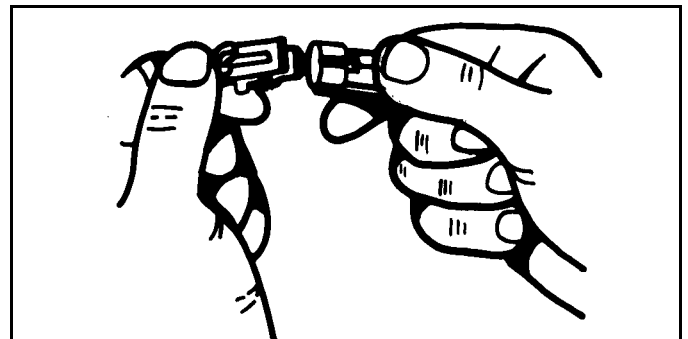













Figure 3-11

TORQUE SPECIFICATIONS

SAE Grade and Head Markings	1 or 2 No Marks 	5 5.1 5.2   	8 8.2  
	2 No Marks 	5  	8  

	Grade 1		Grade 2		Grade 5, 5.1 or 5.2		Grade 8 or 8.2	
	Lubricated ^a	Dry ^b	Lubricated ^a	Dry ^b	Lubricated ^a	Dry ^b	Lubricated ^a	Dry ^b
SIZE	lb-ft	lb-ft	lb-ft	lb-ft	lb-ft	lb-ft	lb-ft	lb-ft
10-24			21*	27*	32*	43*	45*	60*
1/4	2.8	3.5	4.5	5.5	7	9	10	12.5
5/16	5.5	7	9	11	15	18	21	26
3/8	10	13	16	20	26	33	36	46
7/16	16	20	26	32	41	52	58	75
1/2	25	31	39	50	63	80	90	115
9/16	36	45	56	70	90	115	130	160
5/8	50	62	78	100	125	160	160	225
Metric Grade 8.8								
SIZE	lb-ft		SIZE	lb-ft				
M6	7		M12	60				
M8	17		M14	95				

DO NOT use these values if a different torque value or tightening procedure is given for a specific application.

Fasteners should be replaced with the same or higher grade. If higher grade fasteners are used, these should only be tightened to the strength of the original.

^a "Lubricated" means coated with a lubricant such as engine oil, or fasteners with phosphate and oil coatings.

^b "Dry" means plain or zinc plated without any lubrication

* Values with asterisk are in lb-in.

WIRING SCHEMATIC - GAS SPREADER (Cab Control and Spreader Side)

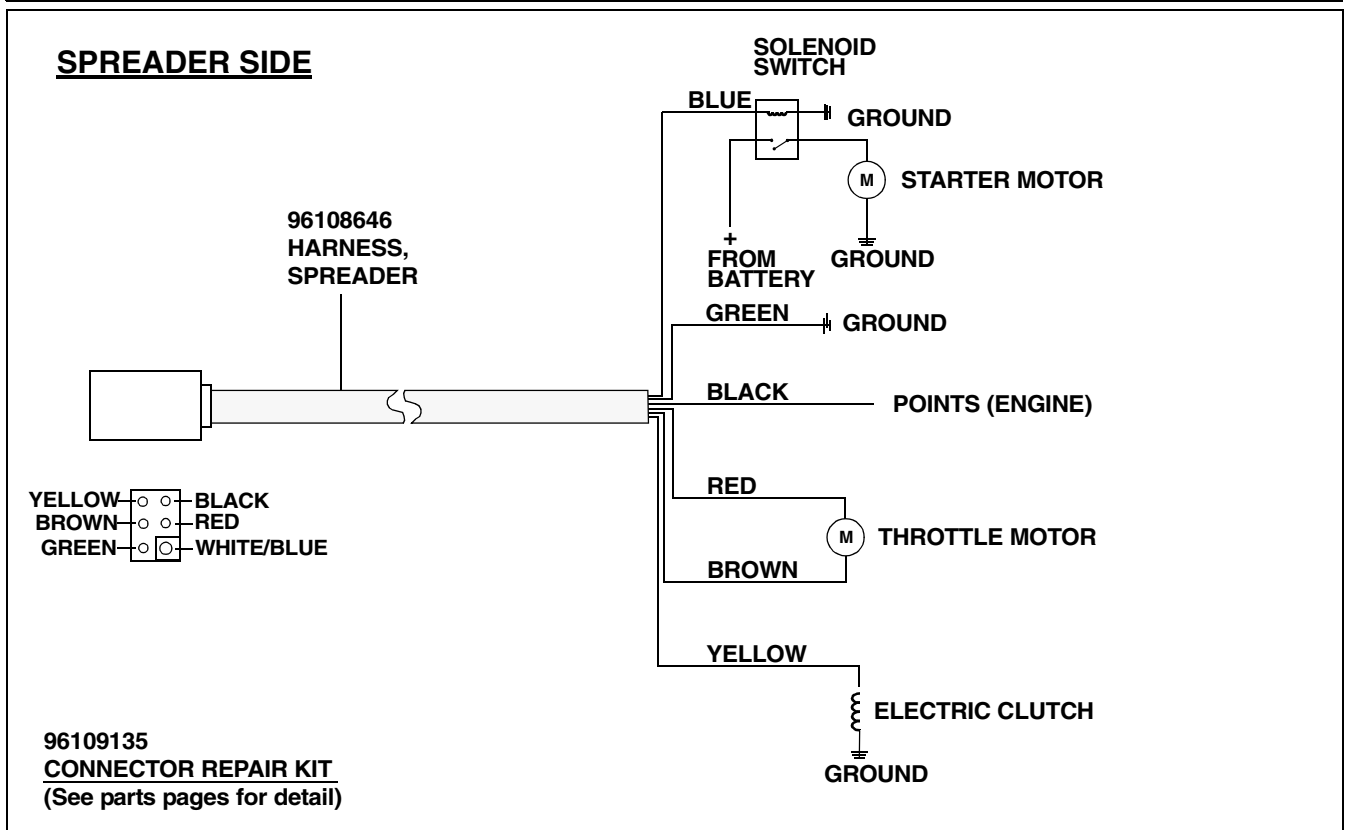
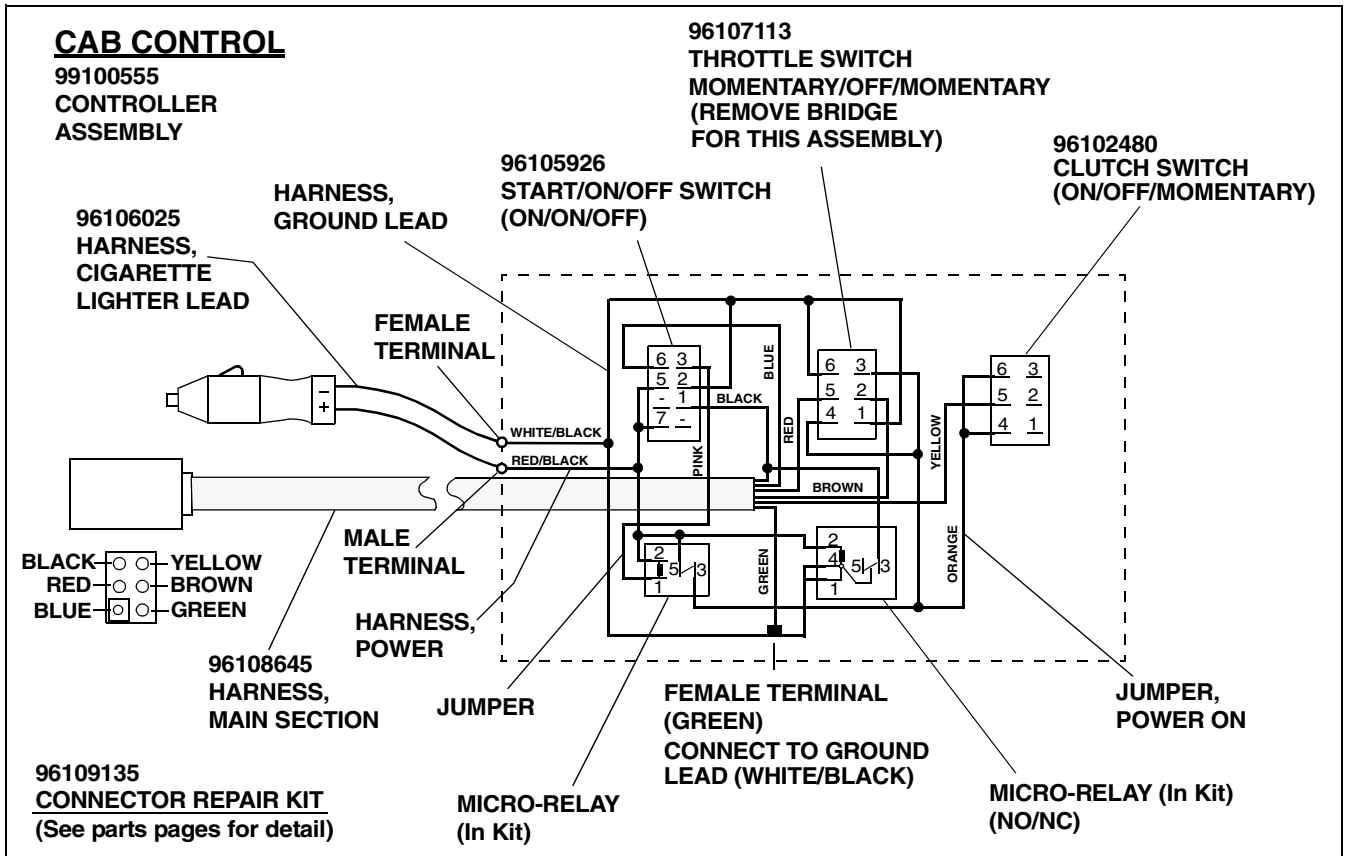

ELECTRICAL TROUBLESHOOTING - GAS SPREADER

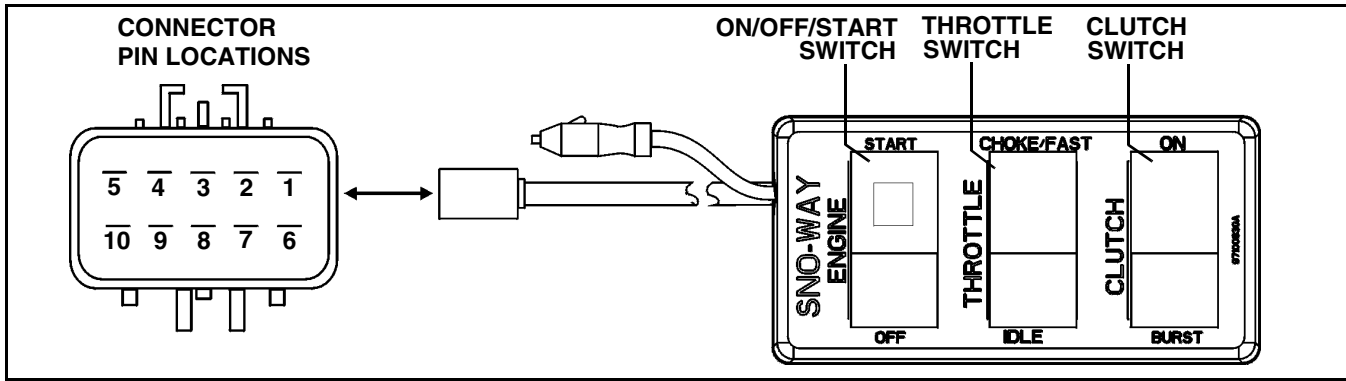

MAIN HARNESS									
FUNCTION	SWITCH NAME	ACTIVATED WIRE COLOR	SWITCH ON	MIDDLE	OFF	MAIN RELAY #1	ENGINE CUT OFF RELAY #2 NO/NC	CIG. ADAPTER	PIN #
Starting Motor	On/Off/Start	Blue	Starter Motor	-	-	On	On	On	3
Controller On	On/Off/Start	Orange (+12V)		Power to Control		On	On	On	OC
Controller Off/Engine Off	On/Off/Start	Black (Grounded)			Power Off to Control	Off	Off	On	1, 6
Clutch On	Clutch	Yellow (+12V)	On			On	On	On	4
Clutch Momentary On	Clutch	Yellow (+12V)		Momentary		On	On	On	4
Clutch Off	Clutch	Yellow (OC)			Off	On	On	On	OC
Throttle Up/Choke	Throttle	Brown (+12V) Red (-12V)	On			On	On	On	(+) 5, (-) 2
Neutral Throttle	Throttle	Brown and Red (OC)		Off		On	On	On	OC
Minimum Throttle	Throttle	Red (+12V) Brown (-12V)			On	On	On	On	(+) 2, (-) 5
Cig. Lighter Unplugged		Black (Grounded)				Off	Off	Pulled Out	1, 6
Activates Light on Switch		Pink (+12V)							NA
Controller Ground Through Cig. Lighter		White/Black							NA
Ground Harness		Green							6

SPREADER HARNESS		
ACTIVATED WIRE COLOR	PIN #	FUNCTION
Black	1	Points (Join 1 & 6, engine stops: points grounded)
Red	2	Activates Throttle Motor to Rev Engine Down
Blue	3	Activates Starter Solenoid to Start Engine
Yellow	4	Activates Clutch
Brown	5	Activates Throttle Motor to Rev Motor Up all the Way to Choke
Green	6	Ground on Spreader

CIRCUIT CHECK CHART (Cigarette Lighter plugged in and has power)							
COLOR	PIN #	MAIN SWITCH ON	MAIN SWITCH OFF	THROTTLE UP	THROTTLE DOWN	ENGINE START	CLUTCH ON
Black	1	OC	1 & 6 Joined	OC	OC	OC	OC
Red	2	OC	OC	-	+	OC	OC
Blue	3	OC	OC	OC	OC	+	OC
Yellow	4	OC	OC	OC	OC	OC	+
Brown	5	OC	OC	+	-	OC	OC
Green (Ground)	6	NA	NA	NA	NA	NA	NA

NOTE: OC= Open Circuit , + = +12V, - = - 12V. Check with Black lead on tester to Green (ground), Red lead on tester to termination point of wire.

WIRING SCHEMATIC - ELECTRIC SPREADER (On/Off Control)

**NOTE: SEE PAGE 32
FOR SERVICE PARTS
DETAIL**

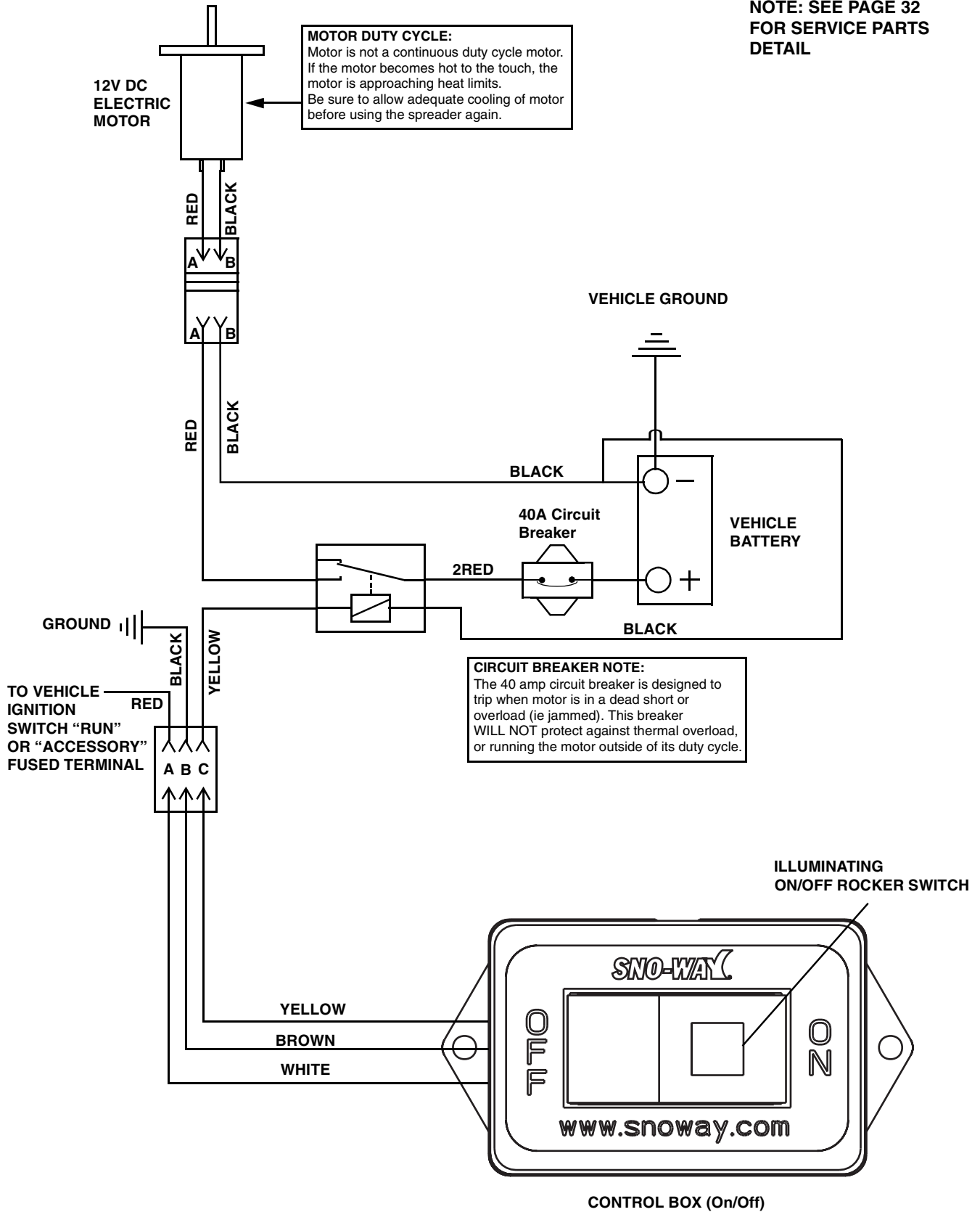

WIRING SCHEMATIC - ELECTRIC SPREADER (Dual Variable Control)

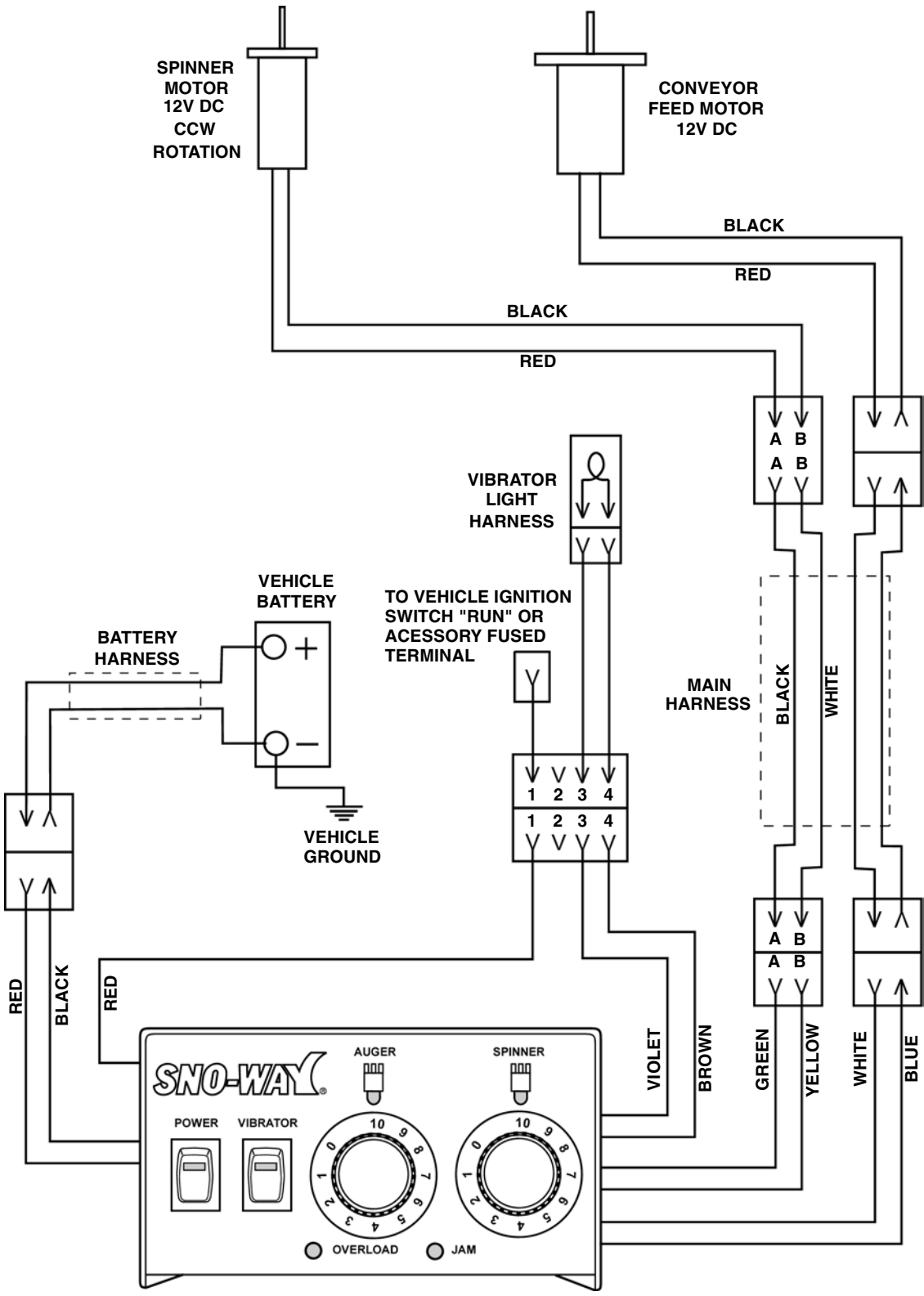

PARTS LIST INTRODUCTION

Our dealership network stands by to provide you with any assistance you may require, including genuine Sno-Way service parts. All parts should be obtained from or ordered through your dealer. Give complete information about the part as well as the Model Number and Serial Number of your machine.

Record the Serial Number in the space provided in your Owner's Manual for quick reference. The Serial Number for the unit is on a plate located on the left frame gusset of the Hopper Frame.

"Right" and "Left" are determined from a position sitting on the Operators Seat of the vehicle.

We reserve the right to make changes or improvements in the design or construction of any part without incurring the obligation to install such changes in any unit previously delivered.

USING THIS PARTS LIST

Below is parts listing with four columns. The first column is the "ITEM", the second is the "PART NUMBER", The third is the "DESCRIPTION" and the fourth is the "QUANTITY".

The **"ITEM"** is the number used in the corresponding illustration.

The **"PART NO."** is the number used to order replacement parts. If a number does not appear in the column the part is only available by ordering the complete assembly.

The **"DESCRIPTION"** is the name of the replacement part. At times the name may be indented, this means that the indented parts are part of the preceding assembly.

The **"QTY."** is the quantity needed to service the assembly illustrated, not the complete product.

ITEM	PART NO.	DESCRIPTION	QTY.
1	96100083	O-ring	1
2	96001529	Elbow	3
3	98100036	Capscrew, Hex., 3/8"-16NC x 7/8"	9

CONVEYOR DRIVE AND IDLER

NOTE: SEE FOLLOWING PAGES
FOR MOTOR DRIVE DETAIL

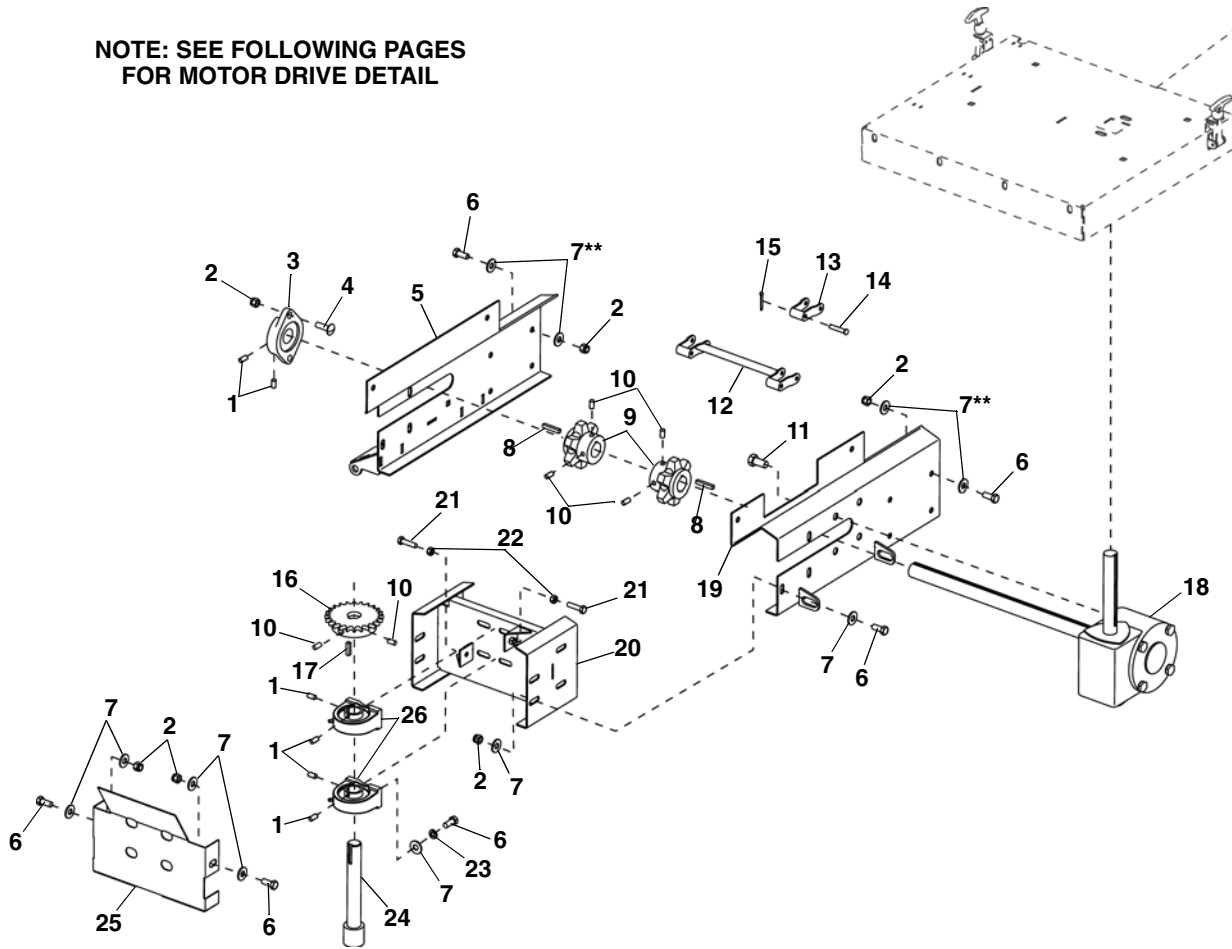

ITEM	PART NO.	DESCRIPTION	QTY.
1	98100355	Set Screw, 1/4"-28 x 1/4"	6
2	98100339	LN, 3/8"-16, SS	18
3	96104651	Bearing, Flanged, 1- 1/8" ID (Includes item 1)	1
4	98100356	CB, Short Sq. Neck Bolt, 3/8"-16 x 1-1/4", SS	2
5	96104736	Take-Up Frame, Left, SS	1
6	98100357	HHCS, Hex, 3/8"-16 x 7/8", SS	20
7	98100124	PW, 3/8", SS	36
8	98100224	Key, Square, 1/4" x 2"	2
9	96104644	Sprocket, Drive, 6 Tooth (Includes item 10)	2
10	98100354	Set Screw, 5/16"-18 x 3/8"	8
11	98100505	HHCS, 1/2"-13 x 1", SS	4
12	96106838	Kit, 15" Wide Chain, Master Link, V-Box (includes item 14-qty 4 & item 15-qty 4)	1
	96106459	Kit, 10" Wide Chain, Master Link, V-Box (includes item 14-qty 4 & item 15-qty 4)	1
13	96107246	Link, Chain V-Box (includes item 14-qty 2 & item 15-qty 2)	1
14	96109229	Clevis Pin, .265 x 1.60	2
15	98100389	Pin, Cotter, 3/32" x 3/4"	2
16	96104634	Sprocket, 24 Tooth, 1.00" Bore	2
17	98100236	Key, Square, 1/4" x 1.00"	2
18	96106730	Gearbox, Electric, 10 Inch, 50:1 ratio	1
	96108602	Gearbox, Electric, 15 Inch, 50:1 ratio	1
	96104638	10 Inch Wide Gearbox, 20:1 ratio	1
	96104723	15 Inch Wide Gearbox, 20:1 ratio	1

CONVEYOR DRIVE AND IDLER

ITEM	PART NO.	DESCRIPTION	QTY.
19	96104724	Take-Up Frame, Right, SS	1
20	96104733	10 Inch Wide H-Frame, SS	1
	96104735	15 Inch Wide H-Frame, SS	1
21	98100503	HHCS, 5/16"-18 x 1-1/4", SS	2
22	98100504	Nut, 5/16"-18	2
23	98100125	Washer, Lock 3/8", SS	4
24	96104726	Shaft w/ Coupler	1
	96113414	Shaft w/ Coupler (Dual Electric V-Box Only)	1
25	96114368	10 Inch Wide Chain Guard, SS	1
	96104730	15 Inch Wide Chain Guard, SS	1
26	96104731	Bearing, 1" Tapped Pillow Block (Includes item 1)	2
27*++	96104739	Chain, Conveyor, 5' 10" Wide, 78 Links, X= 8"	1
28*++	96104646	Chain, Conveyor, 6' 10" Wide, 93 Links, X= 8"	1
29*+++	96108750	Chain, Conveyor, 8' 15" Wide, 121 Links, X=8"	1
30*+++	96108751	Chain, Conveyor, 9' 15" Wide, 136 Links, X= 8"	1
31*+++	96108752	Chain, Conveyor, 10' 15" Wide, 150 Links, X= 8"	1
32*++	96108750	Chain, Conveyor, 8' 15" Wide, 119 Links, X= 10"	1
33*+++	96108751	Chain, Conveyor, 9' 15" Wide, 134 Links, X= 10"	1
34*+++	96108752	Chain, Conveyor, 10' 15" Wide, 148 Links, X= 10"	1

* Not Shown

** Not Used In 5' & 6' Spreaders With Serial Numbers Ending in 300000 Or Later

++ Includes items 14 & 15

+++ Includes items 14 & 15; Also order 96106838 (item 12) - Quantity 2

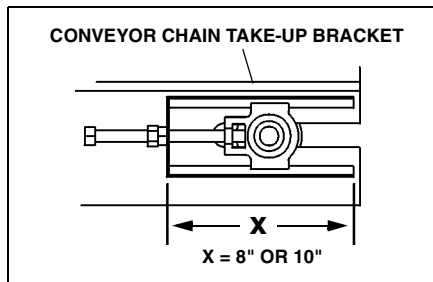

MOTOR PLATE & DRIVE - GAS SPREADER

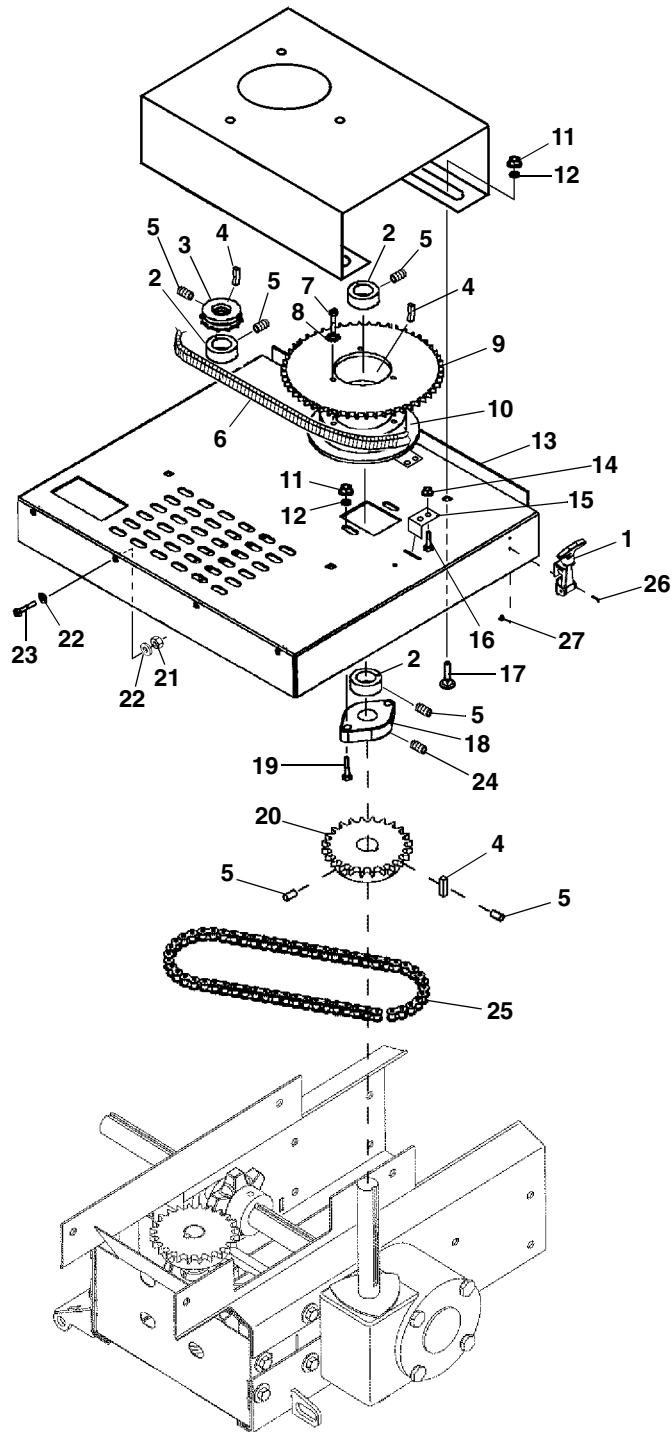

MOTOR PLATE & DRIVE - GAS SPREADER

ITEM	PART NO.	DESCRIPTION	QTY.
1	96114472	Kit, Rubber Hold Down Strap (Includes items 27 & 28)	2
2	96104668	Collar, Locking, 1" I.D. (Includes item #6)	3
3	96104669	Sprocket, 12 Tooth, 1" I.D.	1
4	98100236	Key, Square, 1/4" x 1"	2
5	98100354	Set Screw, 5/16-18 x 3/8"	7
6	96104635	Chain, Drive, 8.0 and 10.5 HP Briggs/Honda, #40 - 31 Link Pairs (62 total links)	1
	96107876	Chain, Drive, 10.5 HP Intek, #40 - 30 Link Pairs (60 total links).	1
7	98100225	Capscrew, Hex, 5/16-18 x 5/8, SS	3
8	98100217	Washer, Lock, 5/16, SS	7
9	96104670	Sprocket, 52 Tooth Electric Clutch	1
10	96111334	Clutch, Assy., V-Box	1
11	98100235	Nut, Hex Nylock, 3/8-16, SS.	10
12	98100124	Washer, Flat, 3/8", SS	10
13		Engine Base, 10 Inch Wide, SS	1
		Engine Base, 15 Inch Wide, SS	1
14	98100255	Nut, Hex, 1/4-20	2
15	96107991	Bracket, Clutch Locator	1
16	98009027	Capscrew, Hex, 1/4-20 x 1	2
17	98100359	Bolt, Carriage, 3/8-16 x 1, SS.	4
18	96104652	Bearing, Flanged, 1" I.D.	1
19	98100357	Capscrew, Hex, 3/8-16 x 7/8, SS	2
20	96104645	Sprocket, 16 tooth, 1" Bore (Includes item #6)	1
21	98100358	Nut, Hex Nylock, 5/16-18, SS.	4
22	98100123	Washer, Plain, 5/16, SS	4
23	98100112	Capscrew, Hex, 5/16-18 x 3/4, SS	4
24	98100355	Set Screw, 1/4- 28 x 1/4	2
25	96104635	Chain, Drive, #40 - 31 Link Pairs (62 total links) (Note: For 5 & 6 ft. spreaders, chain reduction will be needed)	1
26		Pan Head Machine Screw, #6-32 x 5/8", SS	4
27		Nut, Nylock, #6-32, SS	4

MOTOR PLATE & DRIVE - ELECTRIC SPREADER

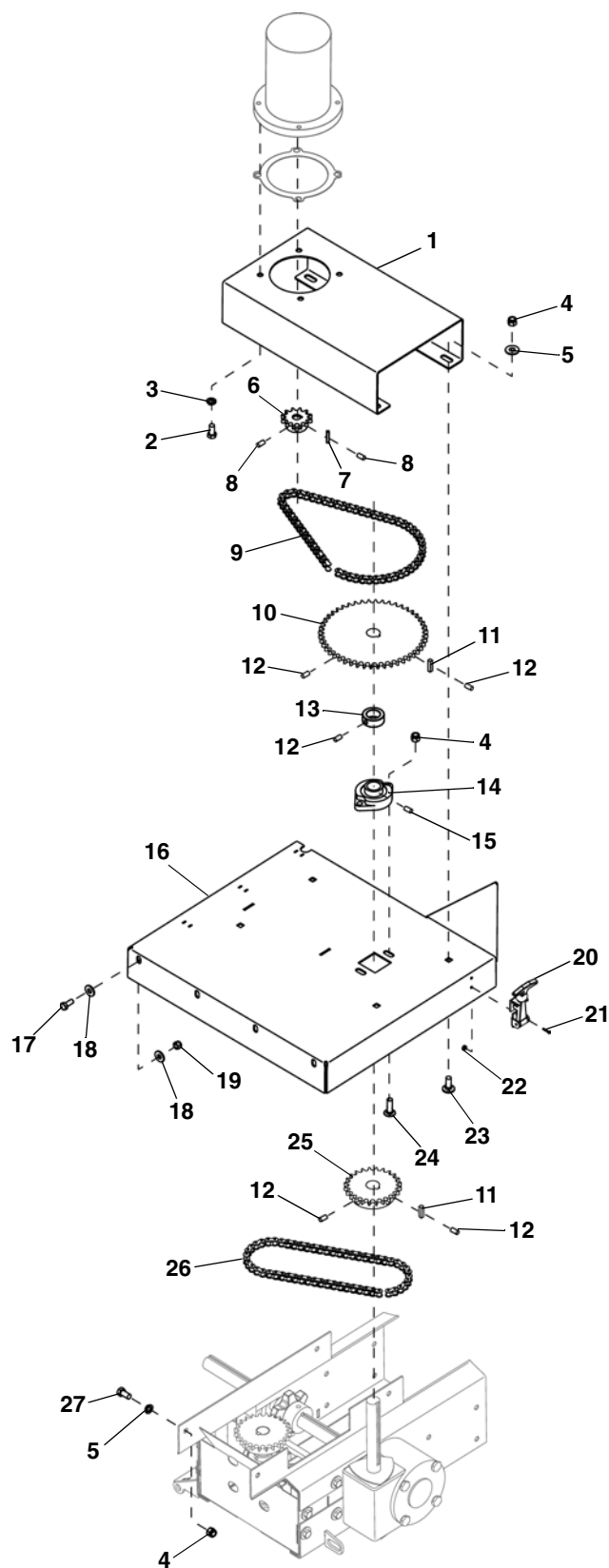

28

Includes 60 Tooth
Components:
Item 1 - 96110357
Item 9 - 96110354
Item 10 - 96110352
Item 25 - 96104634
Item 26 - 96110426

MOTOR PLATE & DRIVE - ELECTRIC SPREADER

ITEM	PART NO.	DESCRIPTION	QTY.
1	96106731	Electric Motor Plate, SS	1
	96110357	Bracket, Electric Motor Mount (60 Tooth Sprocket)	1
2	98100214	Capscrew, Hex, 3/8"-16 x 3/4", SS	4
3	98100125	Washer, Lock, 3/8", SS	4
4	98100339	Nut, Hex Nylock, 3/8"-16, SS	10
5	98100124	Washer, Flat, 3/8", SS	8
6	96106732	Sprocket, 12 Tooth, 5/8" Bore, (Includes item XX)	1
7	98100493	Key, Square, 3/16" x 1"	1
8	98100494	Set Screw, 1/4"-20 x 3/8"	2
9	96110436	Chain, Drive, Electric V-Box, (46 and 48 tooth Drives), #40 - 31.5 Link Pairs (64 total links) (May require link reduction on your application)	1
	96110354	Chain, Drive, Electric V-Box, (60 Tooth Drive Sprocket)	1
10*	96106734	Sprocket, 48 tooth (Includes items 12).	1
	96110352	Sprocket, 60 tooth (8 Foot Electric V-Box Spreaders)	1
11	98100236	Key, Square, 1/4" x 1"	2
12	98100354	Set Screw, 5/16"-18 x 3/8"	5
13	96104668	Collar, Locking, 1" I.D., (Includes item 12)	1
14	96104652	Bearing, Flanged, 1" I.D., (Includes item 15)	1
15	98100355	Set Screw, 1/4"-28 x 1/4	1
16		Mount, Electric Motor, 10 Inch Wide, SS	1
		Mount, Electric Motor, 15 Inch Wide, SS	1
17	98100112	Capscrew, Hex, 5/16"-18 x 3/4, SS	4
18	98100123	Washer, Plain, 5/16", SS	8
19	98100118	Locknut, Hex Nylon Insert, 5/16"-18, SS	4
20	96114472	Kit, Strap, Rubber Hold Down (Includes items 21 & 22)	2
21		Pan Head Machine Screw, #6-32 x 5/8", SS	8
22		Nut, Hex Nylock, #6-32, SS	8
23	98100359	Bolt, Carriage, 3/8"-16 x 1, SS	4
24	98100356	Bolt, Carriage, 3/8"-16 x 1-1/4", SS	2
25	96104634	Sprocket, 24 Tooth, 1.00" Bore, (Includes items 12)	1
26	96110426	Chain, Drive, #40 - 29 Link Pairs (58 total links)	1
27	98100357	HHCS, 3/8"-16 x 7/8" SS	4
28**	96111777	Kit 60 Tooth Conversion	1

* Item #10 used to be a 46 tooth sprocket. Due to design development changes, item #10 has changed to a 48 tooth sprocket. Spreaders with 46 tooth sprockets will require chain reduction to accommodate the smaller 46 tooth sprocket.

** If you have a 48 tooth, you can convert to a 60 tooth using this kit. This conversion will add greater torque to conveyor chain.

DUAL MOTOR PLATE & DRIVE - ELECTRIC SPREADER

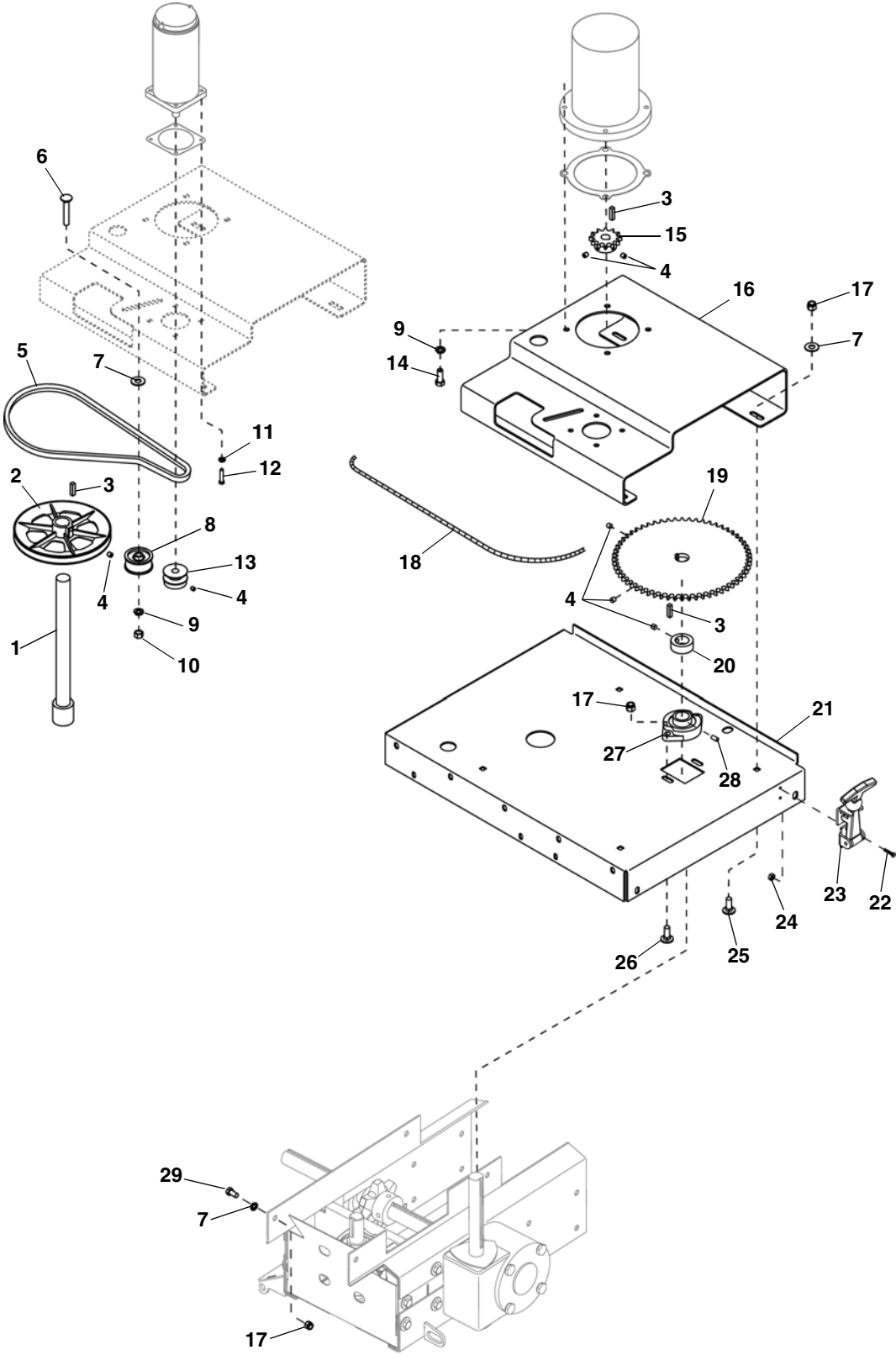

DUAL MOTOR PLATE & DRIVE - ELECTRIC SPREADER

ITEM	PART NO.	DESCRIPTION	QTY.
1	96113414	Shaft, Swingaway	1
2	96113413	Sheave, 7"	1
3	98100236	Key, Square, 1/4" x 1"	3
4	98100354	Set Screw, 5/16"-18 x 3/8"	7
5	96112900	Belt, AX33, (1/2" x 35"	1
6	98100128	CB, 3/8"-16 x 2-1/4"	1
7	98100124	Washer, Plain, 3/8", A Wide, SS.	9
8	96102034	Pulley, 2" Idler.	1
9	98100125	Washer, Lock, 3/8", SS.	5
10	98100120	Nut, 3/8"-16, SS	1
11	98009226	Washer, Lock, 1/4", SS.	4
12	98100139	Bolt, Hex Washer Head, 1/4"-20 x 1"	4
13	96102016	Sheave, 1-1/2"	1
14	98100214	Capscrew, Hex, 3/8-16 x 3/4"	4
15	96106732	Sprocket, 12 Tooth, 5/8" Bore.	1
16		Motor Plate, 10" Wide	1
17	98100339	Nut, Hex Nylock, 3/8"-16, SS	10
18	96110436	Chain, 31.5 Link Pairs (64 total links) [48 Tooth]	1
19	96106734	Sprocket, 48 Tooth	1
20	96104668	Collar, Locking, 1" I.D., (Includes item 6)	1
21		Mount, Electric Motor, 10" Wide, SS	1
22		Pan Head Machine Screw, #6-32 x 5/8", SS	4
23	96114472	Kit, Rubber Hold Down Strap (Includes items 22 & 24)	2
24		Nut, Nylock, #6-32, SS.	4
25	98100359	Bolt, Carriage, 3/8-16 x 1", SS	4
26	98100356	Bolt, Carriage, 3/8-16 x 1-1/4", SS	2
27	96104652	Bearing, Flanged, 1" I.D., (Includes item 28)	1
28	98100355	Set Screw, 1/4"-28 x 1/4"	1
29	98100357	HHCS, 3/8"-16 x 7/8" SS	4

ELECTRIC THROTTLE

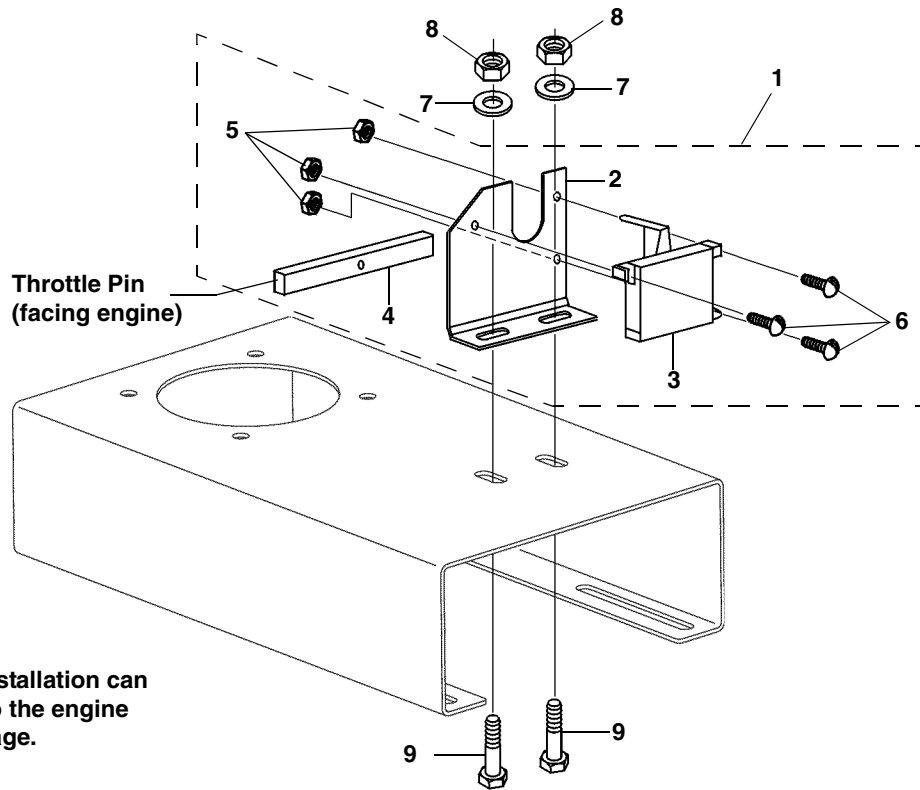

NOTE: Improper installation can result in damage to the engine choke throttle linkage.

ITEM	PART NO.	DESCRIPTION	QTY.
1	96109187	Kit, Throttle, 6.0 HP Intek	1
	96109189	Kit, Throttle, 8 or 9 HP Briggs & 10.5 HP Intek	1
	96109190	Kit, Throttle, 11 HP Honda	1
2		Bracket, Electric Throttle (order applicable kit).	1
3		Motor, Electric Throttle (order applicable kit)	1
4	96107961	Electric Throttle Arm, 6.0 Intek	1
	96104773	Electric Throttle Arm, 8.0 HP Briggs.	1
	96107080	Electric Throttle Arm, 11.0 HP Honda.	1
5	98100502	Nut, Nylock, #6-32, SS.	3
6	98100501	Pan Head Machine Screw, #6-32 x 5/8", SS	3
7	98100240	Washer, Plain, 1/4 SS.	2
8	98100336	Nut, Nylock, 1/4-20 SS.	2
	98100334	Bolt, Hex, 1/4-20 x 3/4, SS.	2

DECAL AND DECAL LOCATION

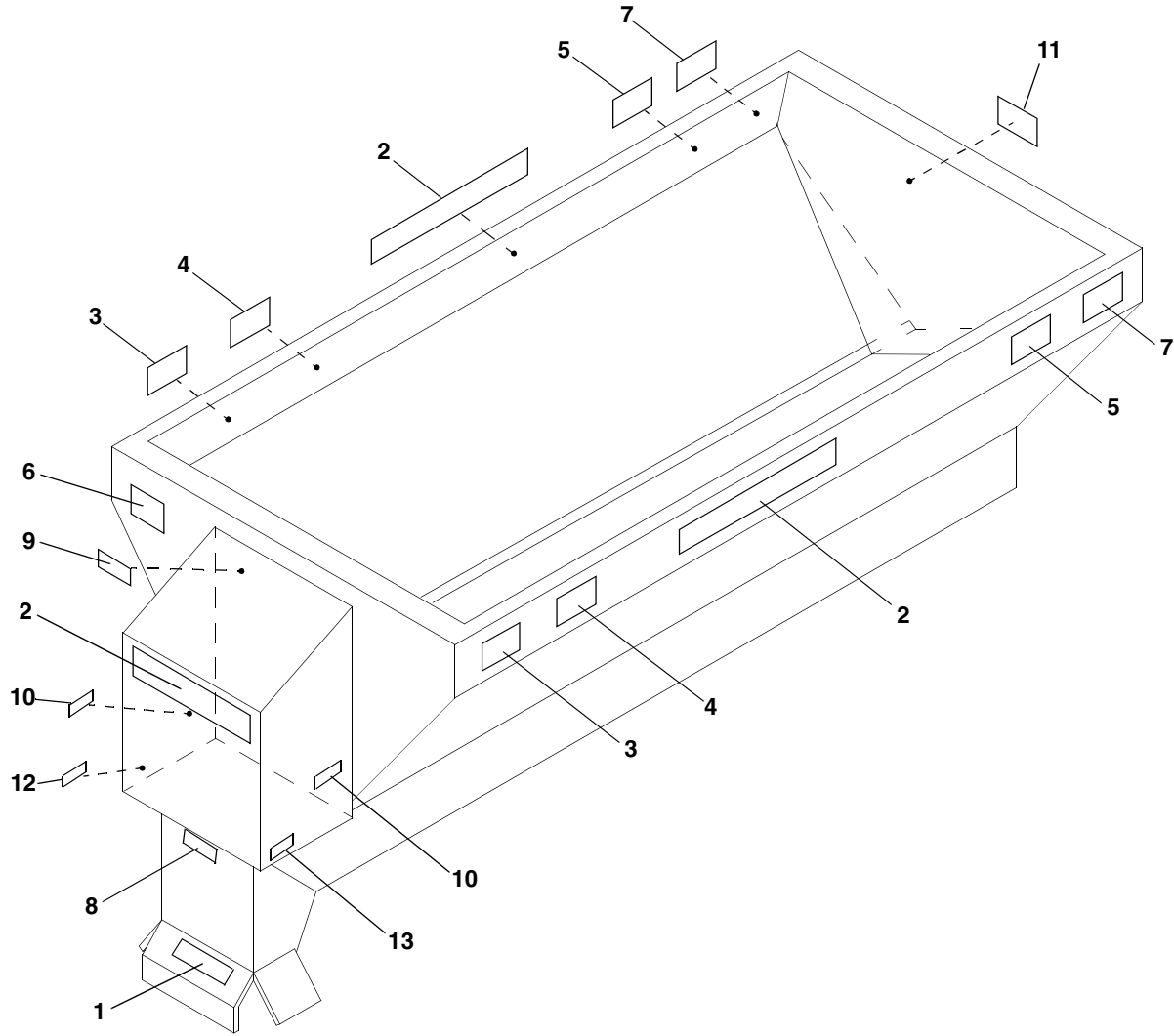

ITEM	PART NO.	DESCRIPTION	QTY.
1		Decal, Warning, Flying Debris	1
2		Decal, 'Sno-Way'	3
3		Decal, Warning, Do Not Enter Hopper	2
4		Decal, Important, Material	2
5		Decal, Warning, Do Not Exceed GVWR.	2
6		Decal, Warning, gasoline is flammable	1
7		Decal, Warning, Do Not Ride	2
8		Decal, Warning, Keep All Guards.	1
9		Plate, Serial No.	1
10		Decal, Warning, Rotation & Pinch Point	2
11		Decal, Warning, Keep Hands & Feet	1
12		Decal, Warning, Shut Off	1
13		Decal, Caution, Hot Engine Exhaust	1
14*	96104557	Decal Kit, Gas	1
15*	96107040	Decal Kit, Electric	1

* Not Shown

SPREADER BODY

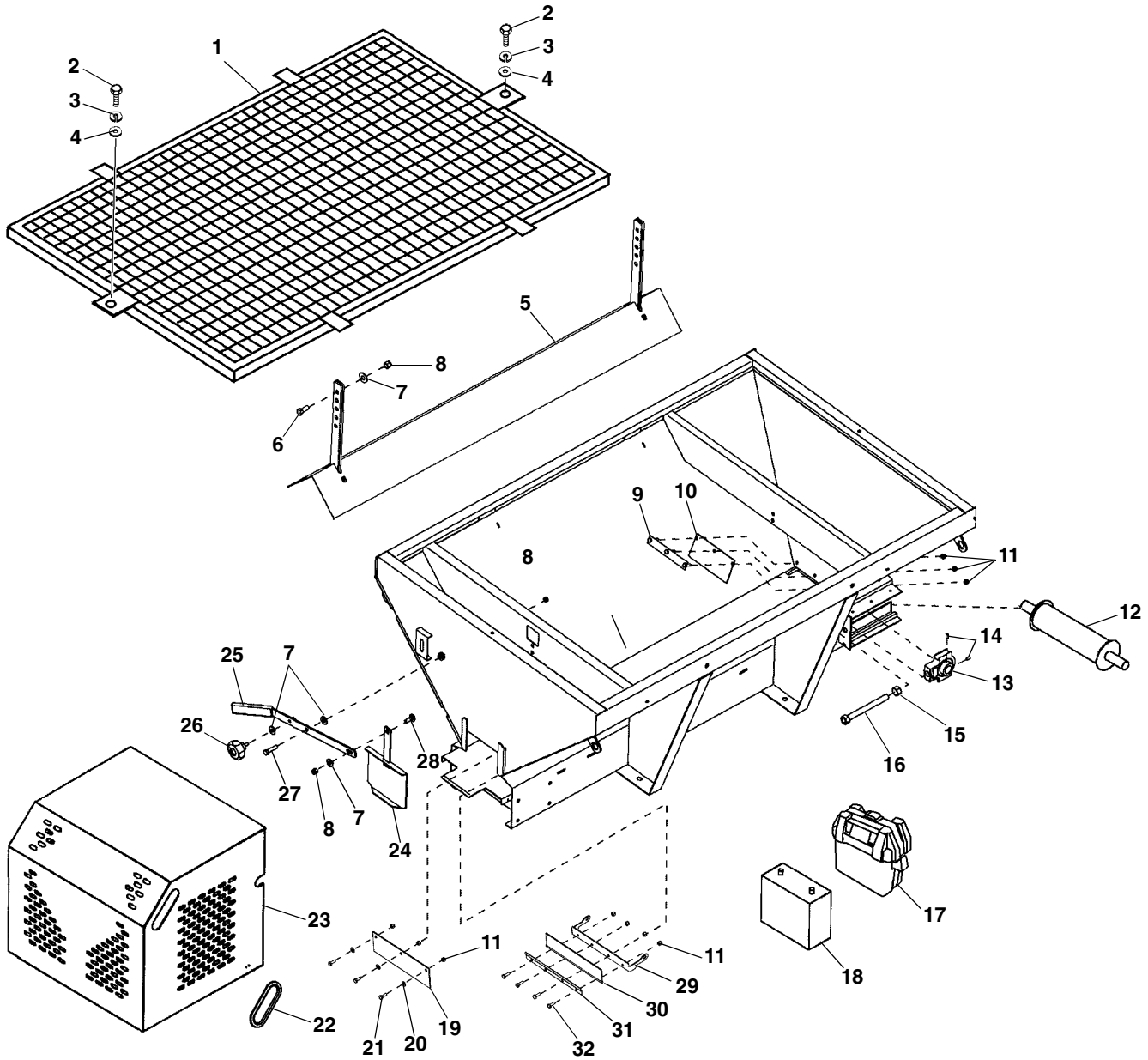

ITEM	PART NO.	DESCRIPTION	QTY.
1	96114362	Top Screen, 5'	1
	96114363	Top Screen, 6'	1
	99100429	Top Screen, 8'	1
	99100522	Top Screen, 9'	1
	99100674	Top Screen, 10'	1
	2	98100112	HHCS, 5/16"-18 x 3/4", SS
98100331		Washer, Lock, 5/16", SS	2
3	98100123	Washer, Plain, 5/16", SS	2
5	96114373	Inverted Vee, 5', SS (Includes items 6-8)	1
	96114379	Inverted Vee, 6', SS (Includes items 6-8)	1
	99100461	Inverted Vee, 8', SS (Includes items 6-8)	1
	99100517	Inverted Vee, 9', SS (Includes items 6-8)	1
	99100678	Inverted Vee, 10', SS (Includes items 6-8)	1

SPREADER BODY

ITEM	PART NO.	DESCRIPTION	QTY.
6	98100357	HHCS, 3/8"-16 x 7/8". SS	4
7	98100124	PW, 3/8", A Wide, SS	7
8	98100339	LN, 3/8"-16, Nylon Insert, SS	6
9	96104749	10 Inch Wide Rear Wiper Plate	1
	96104749	15 Inch Wide Rear Wiper Plate	1
10	96104653	10 Inch Wide Rubber Wiper	1
	96104750	15 Inch Wide Rubber Wiper	1
11	98100336	Locknut, Nylon Insert, 1/4"-20, SS	11
12	96104640	10" Wide Idler Roller	1
	96104751	15" Wide Idler Roller	1
13	96104762	Bearing, Take-Up (Includes item 14)	2
14	98100355	Set Screw, 1/4"-28 x 1/4"	2
15	98100220	Nut, Hex, 5/8"-11 SS	2
16	98100237	Capscrew, Hex, 5/8"-11 x 6", SS	2
17	96107051	Battery Box, Spreader	1
18	96104756	Battery, 12 Volt Dry Cell	2
19	96104654	10" Wide Rear Rubber Wiper	1
	96104757	15" Wide Rear Rubber Wiper	1
20	98100240	Washer, Plain, 1/4", SS	4
21	98100127	Bolt, 1/4"-20 x 1-1/2", SS	1
22	98109186	Handle, Hood, Rubber Trim Strip	2
23		Assy, 10" Wide Cover, Engine, SS	1
		Assy, 10" Wide Cover, Electric Motor, SS	1
		Assy, 15" Wide Cover, Engine, SS	1
		Assy, 15" Wide Cover, Electric Motor, SS	1
24	96104759	10" Wide Door, Feed Gate, SS (For SN Before 300000, , also order Item 29)	1
	96104761	15" Wide Door, Feed Gate, SS	1
25	96114434	10" Wide Handle, Feed Gate, SS	1
	96104748	15" Wide Handle, Feed Gate, SS	1
26	96104746	Knob, Locking Control	1
27	98100213	Capscrew, Hex, 3/8" x 1-1/2", SS	1
28	98100359	Bolt, Carriage, 3/8"-16 X 1.00", SS	1
29	96114222	Bracket, Brush	1
30	96114223	Brush, Lower	1
31	96114221	Bottom Brush Plate	1
32	96100334	Capscrew, Hex, 1/4"-20 x 3/4"	4

10" CHUTE/SPINNER ASSEMBLY

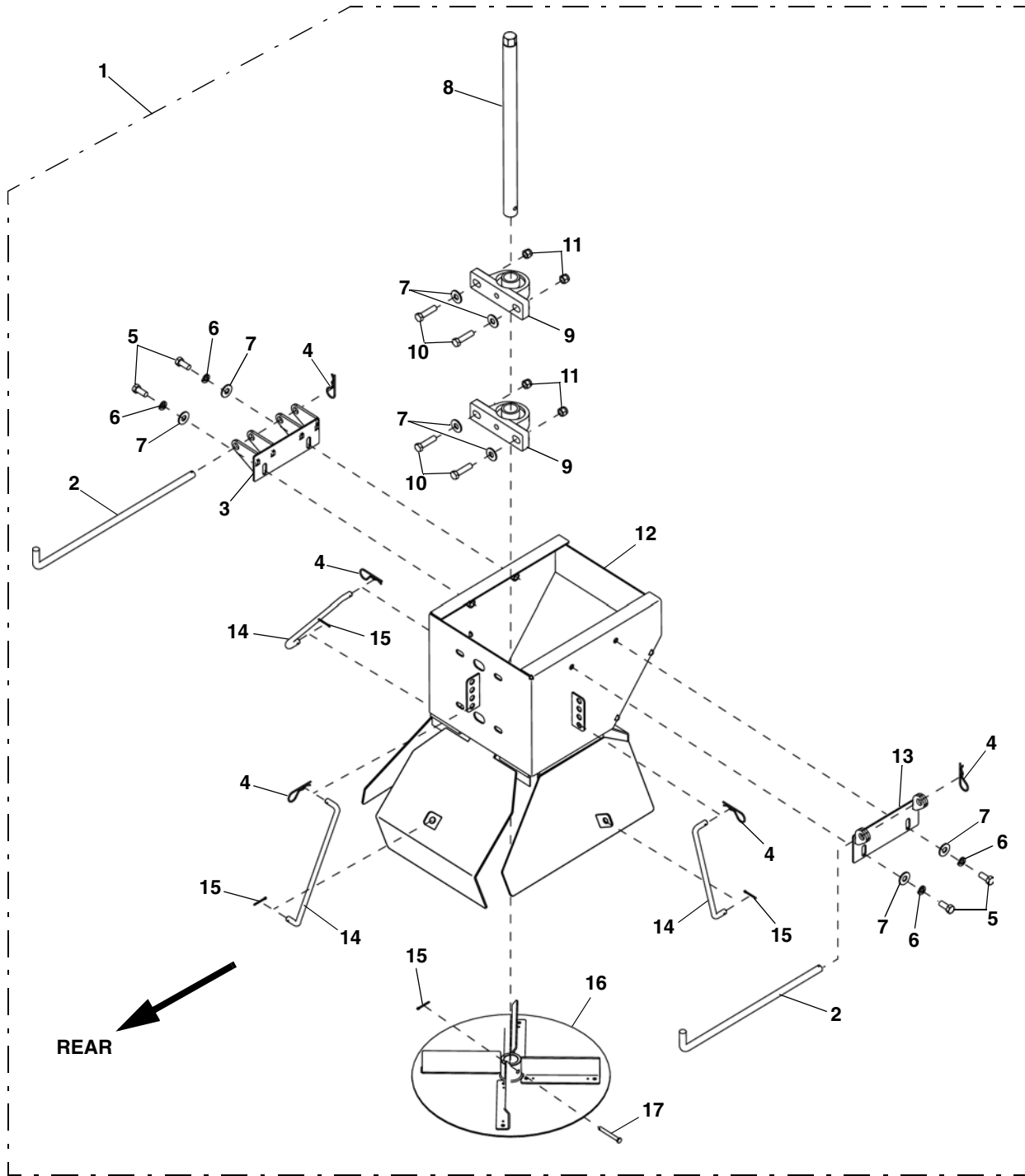

10" CHUTE/SPINNER ASSEMBLY

ITEM	PART NO.	DESCRIPTION	QTY.
1	96114371	10" Wide - Standard Chute/Spinner Assy, SS	1
2	96104685	Chute Pin, 1/2" x 14", SS	2
3	96114442	Chute Hanger Bracket, DS, SS (With Spreader S.N. 300000 or later) . . .	1
	96107707	Chute Hanger Bracket, DS, SS (With Spreader S.N. 299999 or earlier) . .	1
4	98100205	Hairpin Cotter, 3/32" x 2-1/4"	5
5	98100357	Capscrew, Hex, 3/8"-16 x 7/8", SS	4
6	98100125	Washer, Lock, 3/8 SS	4
7	98100124	Washer, Flat, 3/8, SS	8
8	96104625	Standard Shaft, 16" Long	1
9	96104633	Pillow Block Bearing - 1"	2
10	98100213	Capscrew, Hex, 3/8"-16 x 1-1/4", SS	4
11	98100339	Locknut, Nylon Insert, 3/8"-16, SS	4
12		Short Chute, SS	1
13	96107706	Chute Hanger Bracket, PS, SS	1
14	96104629	Control Rod - 10"	3
15	98009159	Cotter Pin, 3/32" x 1"	4
16	96104628	Spinner Disk-SS	1
17	98100230	Clevis Pin, 1/4" x 2"	1

15" CHUTE/SPINNER ASSEMBLY

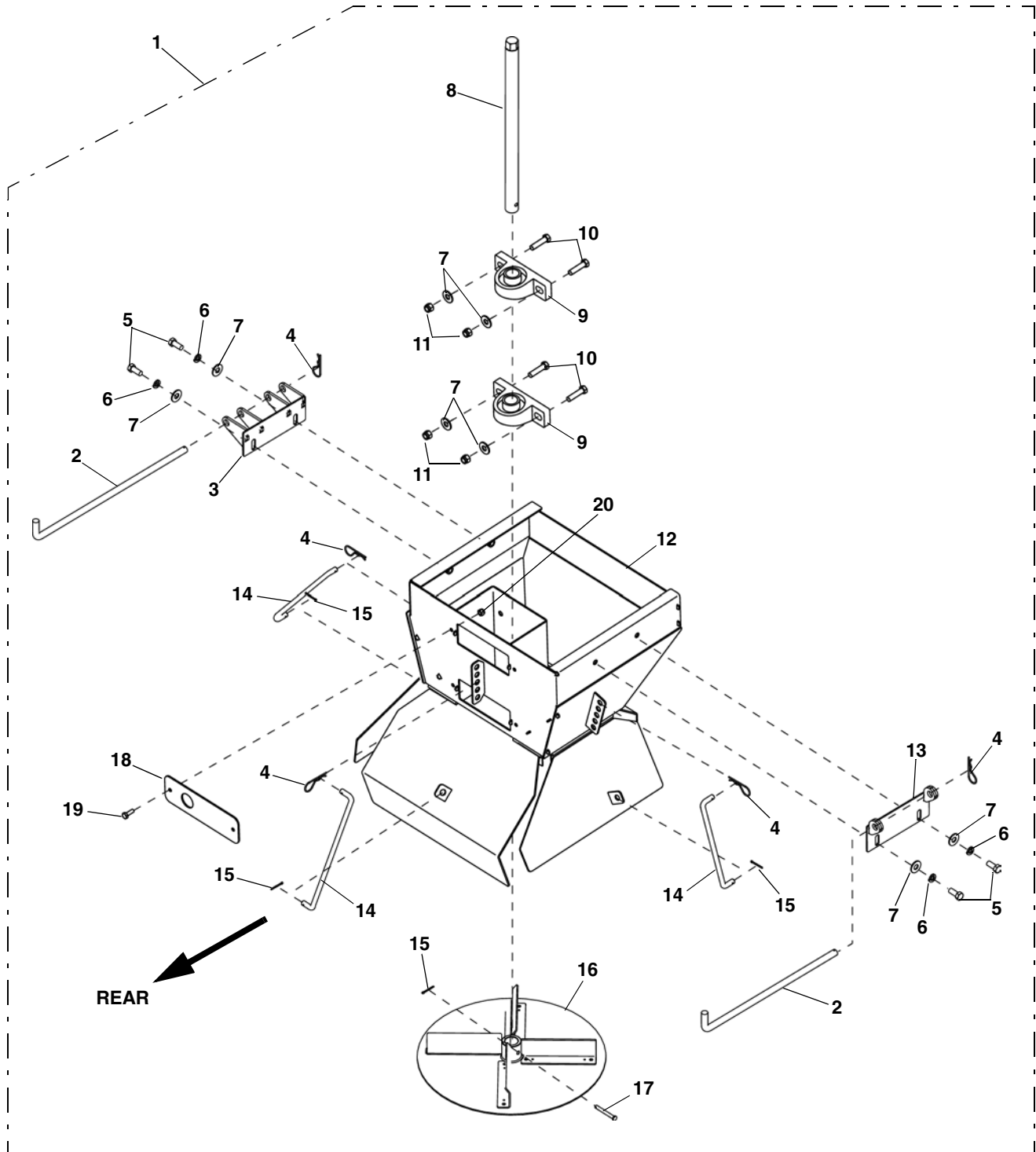

15" CHUTE/SPINNER ASSEMBLY

ITEM	PART NO.	DESCRIPTION	QTY.
1	99100451	15" Wide - Standard Chute/Spinner Assy, SS	1
	99100435	15" Wide - Extended Chute/Spinner Assy, SS	1
2	96104685	Chute Pin, 1/2" x 14", SS	2
3	96114442	Chute Hanger Bracket, DS, SS (With Spreader S.N. 300000 or later) . . .	1
	96107707	Chute Hanger Bracket, DS, SS (With Spreader S.N. 299999 or earlier) . .	1
4	98100205	Hairpin Cotter, 3/32" x 2-1/4"	5
5	98100357	Capscrew, Hex, 3/8"-16 x 7/8", SS.	4
6	98100125	Washer, Lock, 3/8 SS.	4
7	98100124	Washer, Flat, 3/8, SS	8
8	96104625	Standard Shaft, 16" Long	1
	96104626	Extended Shaft, 28" Long	1
9	96104633	Pillow Block Bearing - 1"	2
10	98100213	Capscrew, Hex, 3/8"-16 x 1-1/4", SS	4
11	98100339	Locknut, Nylon Insert, 3/8"-16, SS.	4
12		Standard Chute, SS	1
13	96107706	Chute Hanger Bracket, PS, SS	1
14	96104629	Control Rod - 10"	3
15	98009159	Cotter Pin, 3/32" x 1"	4
16	96104628	Spinner Disk-SS	1
17	98100230	Clevis Pin, 1/4" x 2"	1
18	96114575	Plate, Bearing Cover	2
19	98100334	Bolt, Hex, 1/4-20 x 3/4, SS.	4
20	98100336	Nut, Nylock, 1/4-20 SS.	4

CAB CONTROL - GAS SPREADER

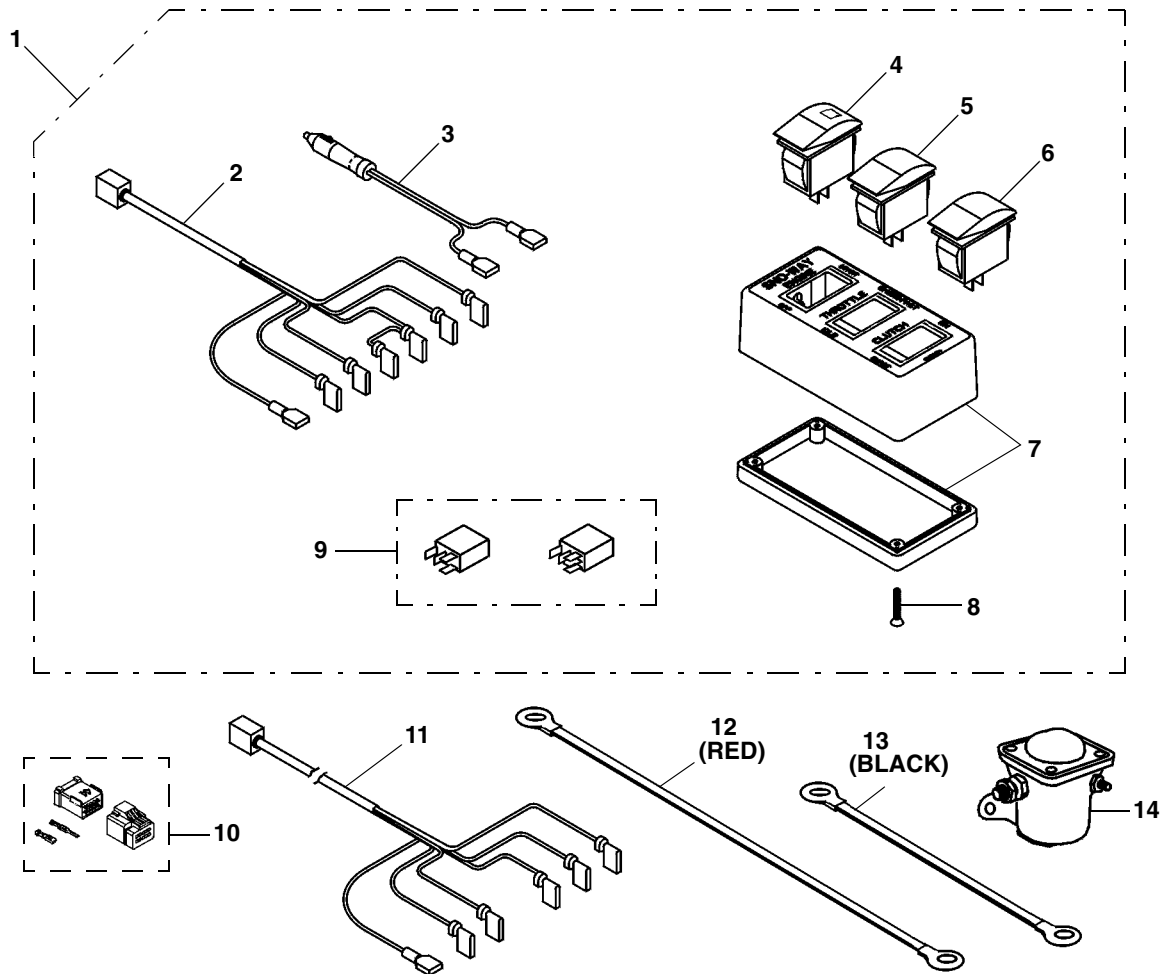

ITEM	PART NO.	DESCRIPTION	QTY.
1	99100555	Controller Assembly	1
2	96108645	Harness, Main Section, 15 Feet	1
3	96106025	Harness, Cigarette Lighter Lead	1
4	96105926	Switch, On/Off/Starter, Illuminated	1
5	96107113	Switch, Throttle, Intermittent	1
6	96102480	Switch, Clutch, Intermittent	1
7	96106095	Cover, Plastic Housing.	1
8		Screw.	1
9	96106846	Kit, Micro-Relay	1
10	96109135	Kit, Connector Repair (includes connectors and terminals).	1
11	96108646	Harness, Spreader, 8 Feet.	1
12	96107143	Positive Lead, Battery-Starter, Honda	1
	96107144	Positive Lead, Battery-Starter, Briggs	1
13	96107142	Negative Lead, Battery	1
14	96105042	Start Solenoid	1

* If Harness Has Molded Connectors, Purchase Connector Repair Kit (#10) For Connector or Terminal Repair.

ON/OFF CONTROL - ELECTRIC SPREADER

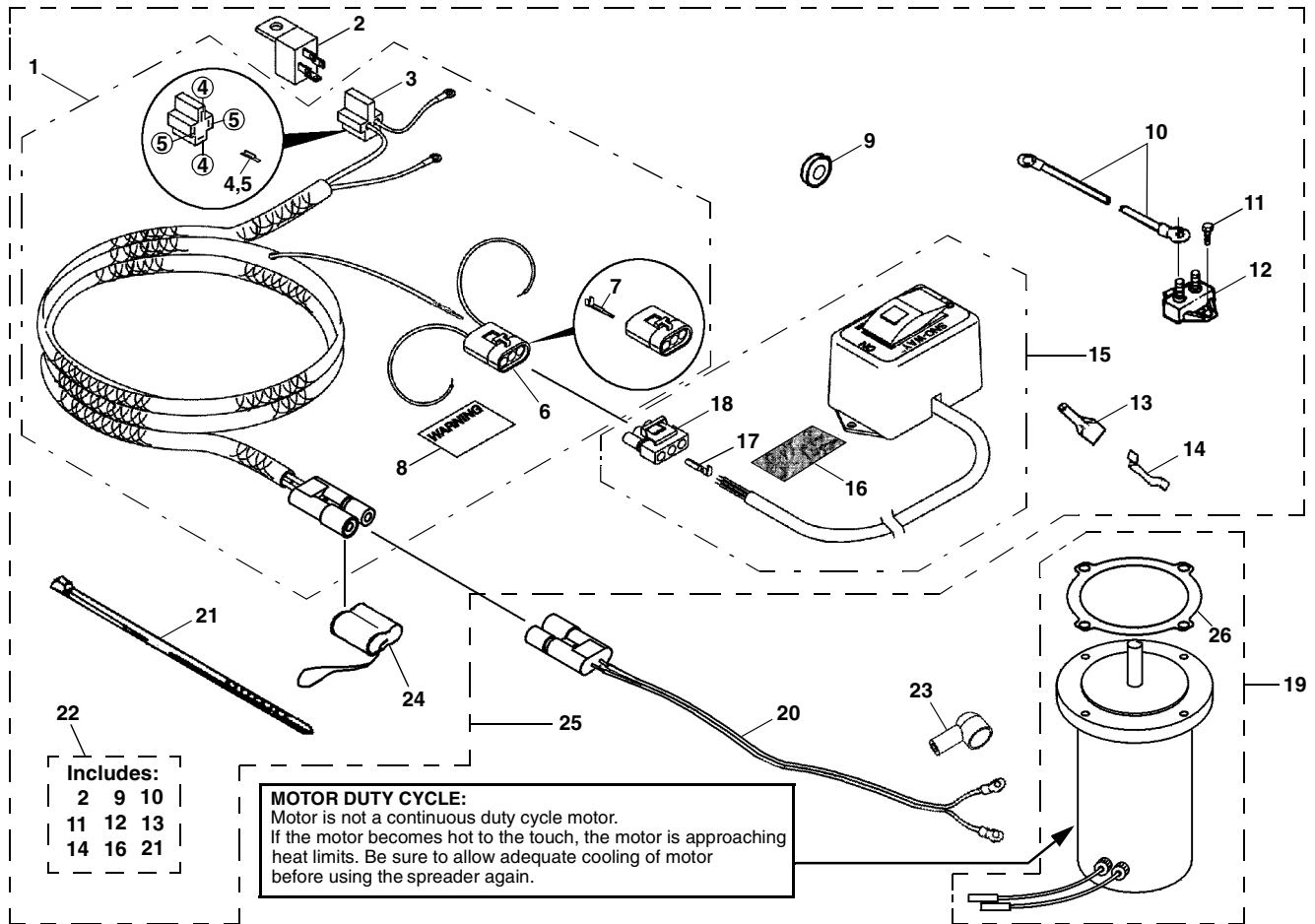

ITEM	PART NO.	DESCRIPTION	QTY
1	96106630	Harness, On/Off Control	1
2	96105891	Relay, 70A.	1
3	96105946	Connector, Harness Relay	1
4	96105947	Terminal, Female, 10-12 AWG, Relay	2
5	96105948	Terminal, Female, 12-16 AWG, Relay	2
6	96105940	Connector, Male	1
7	96105942	Terminal, Male Pin.	3
8		Decal, Warning	1
9	96104893	Grommet, 1/2" dia.	1
10	96106728	Wire, Power.	1
11	98100037	Screw, Self Tapping #10 x 1"	2
12	96102344	Breaker, Circuit, 40A	1
13	96002085	Terminal, 1/4", Female Push-On.	1
14	96101845	Connector, Female	1
	96002083	Tap, 1/4", ATC/ATO Fuse	1
	96101832	Tap, 1/4", Mini Fuse	1
15	96105793	Controller, On/Off	1
16		Strip, Hook and Loop Fastener	1
17	96105943	Terminal, Female.	2
18	96105941	Connector, Female	1
19	96111764	Motor, Electric, 1/2 HP, including Gasket	1
20	96106628	Harness, Motor	1
21		Tie, Cable	5
22	96106729	Bag of Parts (On/Off Control)	1
23	96106374	Boot, Cable (use with ring terminal connection)	1
24	96105082	Cap Cover, Harness End	1
25	99100621	Package, Electric Spreader Harness	1
26	96111763	Gasket (supplied with Motor, item 19).	1

DUAL VARIABLE CONTROL - ELECTRIC SPREADER

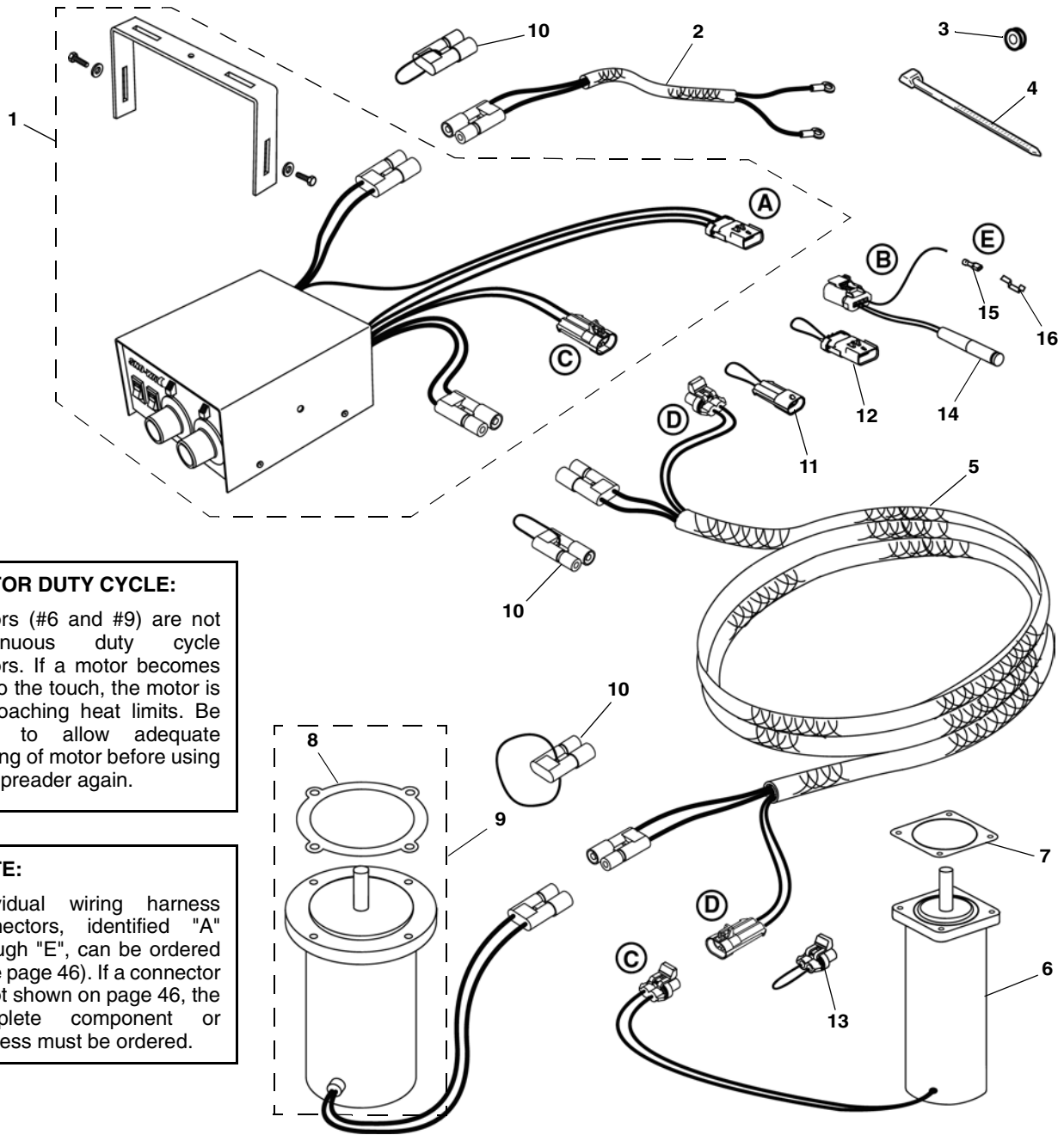

MOTOR DUTY CYCLE:
Motors (#6 and #9) are not continuous duty cycle motors. If a motor becomes hot to the touch, the motor is approaching heat limits. Be sure to allow adequate cooling of motor before using the spreader again.

NOTE:
Individual wiring harness connectors, identified "A" through "E", can be ordered (See page 46). If a connector is not shown on page 46, the complete component or harness must be ordered.

ITEM	PART NO.	DESCRIPTION	QTY
1	96115024	Control, Dual Electric, V-Box	1
2	96113421	Harness, Bat, DEVBX	1
3	96104893	Grommet	1
4		Tie, Cable	1
5	96114865	Harness, Main DEV	1
6	96113295	Motor, Electric, 1/3 HP	1
7	96111763	Gasket (Order Separately)	1
8	96113438	Gasket (Supplied with Motor, item 9)	1
9	96111764	Motor, Conveyor Feed, 1/2 HP	1
10	96105082	Cap Cover, Harness End	3
11	96115129	Cap, Metri Pack, 2-Way, Male	1
12	96112872	Cap, Apex, 4-Way, Male	1
13	96115130	Cap, Metri Pack, 2-Way, Female	1
14	96115368	Vibrator Light Kit	1
15	96113111	Connector, Flat Blade, Female, 1/4"	1
16	96002083	Tap, ATC/ATO Fuse, 1/4"	1
	96101832	Tap, Mini Fuse, 3/16"	1

WIRING HARNESS CONNECTORS

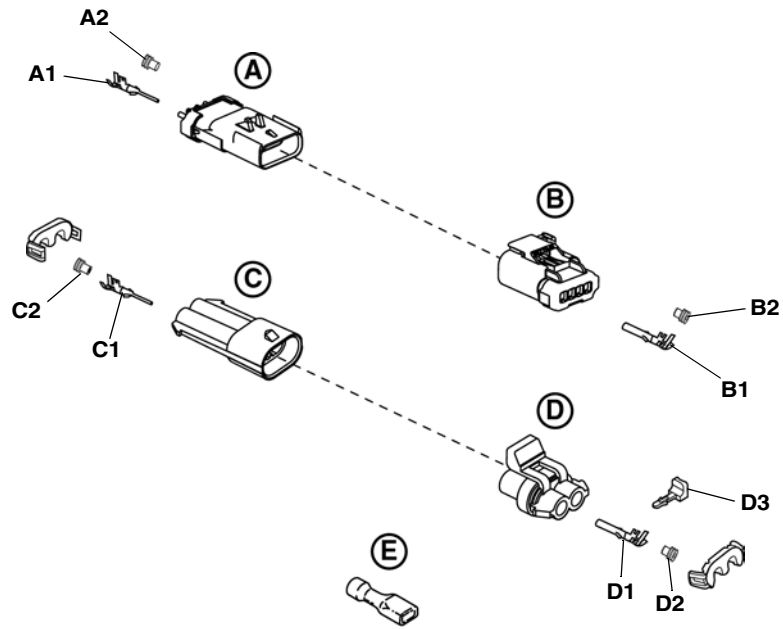

ITEM	PART NO.	DESCRIPTION	QTY
A	96112301	4 Way Connector, Male	A/R
A1	96108661	Terminal, Male	3
A2	96108142	Plug, Cavity	1
B	96112300	4 Way Connector, Female	A/R
B1	96108662	Terminal, Female	3
B2	96108142	Plug, Cavity	1
C	96102441	Connector, Male, 2 Pin, 10/12 GA	A/R
C1	96102442	Terminal, Male	2
C2	96102443	Seal	2
D	96102346	Connector, Female, 2 Pin, 10/12 GA	A/R
D1	96102347	Terminal, Female	2
D2	96102443	Seal	2
D3	96102418	Secondary Lock	1
E	96113111	Connector, Flat Blade, Female, 1/4"	A/R

NUMERICAL INDEX

PART NO.	PAGE	ITEM	PART NO.	PAGE	ITEM	PART NO.	PAGE	ITEM
96002083	44	14	96104733	28	20		42	13
	45	16	96104735	28	20	96107707	40	3
96002085	44	13	96104736	27	5		42	3
96100334	38	32	96104739	28	27	96107876	30	6
96101832	44	14	96104746	38	26	96107961	35	4
	45	16	96104748	38	25	96107991	30	15
96101845	44	13	96104749	38	9	96108142	46	A2
96102016	34	13	96104750	38	10		46	B2
96102034	34	8	96104751	38	12	96108602	27	18
96102344	44	12	96104756	38	18	96108645	43	2
96102346	46	D	96104757	38	19	96108646	43	11
96102347	46	D1	96104759	38	24	96108661	46	A1
96102418	46	D3	96104761	38	24	96108662	46	B1
96102441	46	C	96104762	38	13	96108750	28	29
96102442	46	C1	96104773	35	4		28	32
96102443	46	C2	96104893	44	9	96108751	28	30
	46	D2		45	3		28	33
96102480	43	6	96105042	43	14	96108752	28	31
96104557	36	14	96105082	44	24		28	34
96104625	40	8		45	10	96109135	43	10
	42	8	96105793	44	15	96109187	35	1
96104626	42	8	96105891	44	2	96109189	35	1
96104628	40	16	96105926	43	4	96109190	35	1
	42	16	96105940	44	6	96109229	27	14
96104629	40	14	96105941	44	18	96110352	32	10
	42	14	96105942	44	7	96110354	32	9
96104633	40	9	96105943	44	17	96110357	32	1
	42	9	96105946	44	3	96110426	32	26
96104634	27	16	96105947	44	4	96110436	32	9
	32	25	96105948	44	5		34	18
96104635	30	6	96106025	43	3	96111334	30	10
	30	25	96106095	43	7	96111763	44	26
96104638	27	18	96106374	44	23		45	7
96104640	38	12	96106459	27	12	96111764	44	19
96104644	27	9	96106628	44	20		45	9
96104645	30	20	96106630	44	1	96111777	32	28
96104646	28	28	96106728	44	10	96112300	46	B
96104651	27	3	96106729	44	22	96112301	46	A
96104652	30	18	96106730	27	18	96112872	45	12
	32	14	96106731	32	1	96112900	34	5
	34	27	96106732	32	6	96113111	45	15
96104653	38	10		34	15		46	E
96104654	38	19	96106734	32	10	96113295	45	6
96104668	30	2		34	19	96113413	34	2
	32	13	96106838	27	12	96113414	28	24
	34	20	96106846	43	9		34	1
96104669	30	3	96107040	36	15	96113421	45	2
96104670	30	9	96107051	38	17	96113438	45	8
96104685	40	2	96107080	35	4	96114221	38	31
	42	2	96107113	43	5	96114222	38	29
96104723	27	18	96107142	43	13	96114223	38	30
96104724	28	19	96107143	43	12	96114362	37	1
96104726	28	24	96107144	43	12	96114363	37	1
96104730	28	25	96107246	27	13	96114368	28	25
96104731	28	26	96107706	40	13	96114371	40	1

NUMERICAL INDEX

PART NO.	PAGE	ITEM	PART NO.	PAGE	ITEM	PART NO.	PAGE	ITEM
96114373	37	5	98100236	27	17	99100451	42	1
96114379	37	5		30	4	99100461	37	5
96114434	38	25		32	11	99100517	37	5
96114442	40	3		34	3	99100522	37	1
	42	3	98100237	38	16	99100555	43	1
96114472	30	1	98100240	35	7	99100621	44	25
	32	20		38	20	99100674	37	1
	34	23	98100255	30	14	99100678	37	5
96114575	42	18	98100331	37	3			
96114865	45	5	98100334	35	9			
96115024	45	1		42	19			
96115129	45	11	98100336	35	8			
96115130	45	13		38	11			
96115368	45	14		42	20			
98009027	30	16	98100339	27	2			
98009159	40	15		32	4			
	42	15		34	17			
98009226	34	11		38	8			
98100037	44	11		40	11			
98100112	30	23		42	11			
	32	17	98100354	27	10			
	37	2		30	5			
98100118	32	19		32	12			
98100120	34	10		34	4			
98100123	30	22	98100355	27	1			
	32	18		30	24			
	37	4		32	15			
98100124	27	7		34	28			
	30	12		38	14			
	32	5	98100356	27	4			
	34	7		32	24			
	38	7		34	26			
	40	7	98100357	27	6			
	42	7		30	19			
98100125	32	3		32	27			
	34	9		34	29			
	40	6		38	6			
	42	6		40	5			
98100127	38	21		42	5			
98100128	34	6	98100358	30	21			
98100139	34	12	98100359	30	17			
98100205	40	4		32	23			
	42	4		34	25			
98100213	38	27		38	28			
	40	10	98100389	27	15			
	42	10	98100493	32	7			
98100214	32	2	98100494	32	8			
	34	14	98100501	35	6			
98100217	30	8	98100502	35	5			
98100220	38	15	98100503	28	21			
98100224	27	8	98100504	28	22			
98100225	30	7	98100505	27	11			
98100230	40	17	98109186	38	22			
	42	17	99100429	37	1			
98100235	30	11	99100435	42	1			

SNO-WAY® INTERNATIONAL, INC.

SNO-WAY
SNOW & ICE CONTROL EQUIPMENT

Hartford, WI 53027 USA
Website: www.snoway.com
©2013 Sno-Way® International

NOTES

DEALER PRE-DELIVERY CHECKLIST

The following inspections **MUST** be accomplished prior to delivering the SNO-WAY® V-BOX GAS or ELECTRIC SPREADER to the customer. Place an X ☒ in the box after accomplishing each item on the checklist.

CHECK THAT

- Parts have not been damaged in shipment. Repair or replace items that are loose, dented or missing.
 - All covers, guards and decals are in place and attached securely.
 - The drive chain and the conveyor chains are at the proper tension.
 - Baffles can be adjusted to all positions.
 - Controller and electrical wiring is properly installed.
 - Gasoline engine or electric drive motor is operating properly.
 - Inverted V is installed properly (If applicable: All Electric V-Box (EV) models).
 - Chute has been lined up and spinner shaft - coupling interface mates properly.
- Start the vehicle engine and place an X ☒ in the box after accomplishing each item.

CHECK THAT

- Unit does not start until **START** switch is depressed.
- Drive shaft and spinner rotate freely.
- Drive rotation is correct (clockwise from top of hopper).
- Speed can be adjusted through speed range with controller.
- Burst sequence operates when **clutch** switch is depressed.
- Listen for abnormal noises or vibrations; Repair or replace as necessary.
- Ignition switch safety shutoff functions correctly. (If on-off controller is used.)

DELIVERY CHECKLIST

The following checklist is to be accomplished with the customer present, place an X ☒ in the box after accomplishing each item.

- After giving the customer his operating manual, instruct him to read it **PRIOR** to operating the spreader. If he has any questions or does not understand part(s) of the manual, ask him to contact the dealer for answers or explanations **BEFORE** operating the unit.
- Record the spreader serial numbers, date of purchase, purchaser's name and address, and the dealers name, address and phone number in the space provided on page 1 of the owner's manual.
- Explain spreader connect and disconnect procedures.
- Demonstrate controller operation and burst function.
- Fill out Warranty Registration Card and mail COPY 1 to the factory to validate Warranty. NO Warranty claims can be honored if the Warranty Card is not on file at the factory.

SNO-WAY® INTERNATIONAL, INC.

SNO-WAY
SNOW & ICE CONTROL EQUIPMENT

Hartford, WI 53027 USA
Website: www.snoway.com
©2013 Sno-Way® International