



**Assembly  
&  
Installation Instructions**

**FOR  
SUBFRAME COMPONENTS 99100645**

**TO FIT  
2004- LATER Chevrolet Colorado 4X4 and GMC Canyon 4X4**



1. THINK SAFETY, ALWAYS WEAR SAFETY GLASSES WHEN PERFORMING THE OPERATIONS PRESCRIBED IN THESE INSTRUCTIONS
2. READ ALL INSTRUCTIONS CAREFULLY BEFORE ATTEMPTING INSTALLATION
3. BEFORE BEGINNING WORK MAKE SURE TO SET PARKING BRAKE AND CHOCK WHEELS



### MINIMUM VEHICLE RECOMMENDATIONS

Heavy Duty Alternator                      Heavy Duty Battery  
 Manufacturers Snow Plow Package

### ASSEMBLY TOOLS NEEDED

Impact Sockets                                7/16" – 1-1/8"  
 Impact Sockets Metric                    10mm – 19mm  
 Wrenches                                        7/16" – 1-1/8"  
 Torque Wrench

*NOTE: On some vehicles it may be necessary to use a form of load booster to decrease the vehicle's front suspension sag with the snow plow in place. This can be accomplished with the use of supplementary air bags, booster springs, or similar load boosting devices. Since there are different load boosting devices available, it will up to the customer/end user to decide and purchase the product to suit the application, and not the responsibility of Sno-Way International, Inc.*

### INSTALLATION NOTES

1. Unless otherwise specified, mount all Subframe Components to vehicle before tightening any hardware.
2. It is recommended that LOCTITE®, or similar thread locking product, be used on ALL mounting hardware (i.e. Nuts, Cap Screws, Bolts, etc.).
3. Vehicle should be parked on a level surface with a normal vehicle load on the FRONT suspension.
4. Items in parentheses ( ) refer to quantity required for this step. Items in parentheses with a pound sign (#) indicate the part number as found in the parts list on the last page of this document.  
 Example: (2) 1/2" x 1-1/2" Cap Screws (#5).
5. It maybe necessary to relocate license plate holder. Relocate under the driver's side headlight by drilling new holes in the bumper. Check state and local laws for placement, if needed.

### MOUNTING INSTRUCTIONS

For most applications, removal of the bumper is not needed. However, In order to install the Mounting Assembly (#1) without removing the bumper, you will have to cut the bottom fascia (air dam) for clearance.

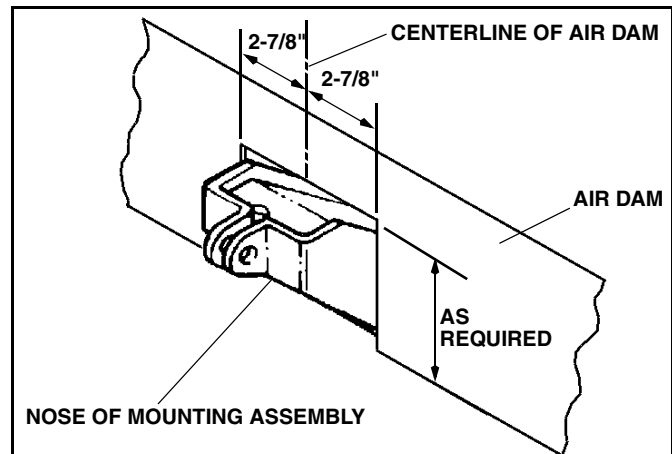

*NOTE: To modify air dam, measure 2-7/8" from each side of center and remove section from between the marked areas to clear nose of Mounting Assembly. Also, trimming around outside vertical brackets may be necessary.*

1. Align the two top holes of a Side Mounting Assembly (LH, #2 or RH, #3) with existing holes in the vehicle frame. The Side Mounting Assembly should be positioned at the outside of the frame rail, and the flange with the single hole should be under the frame rail. Use (2) 1/2"-13 x 4" Hex Cap Screws (#8) to temporarily secure the Side Mounting Assembly.
2. Using the hole in the flange of the Side Mounting Assembly and a hole in the bottom of the vehicle frame as a template, drill a 1/4" pilot hole up through the vehicle frame, then finish drill to 17/32". Remove hardware.

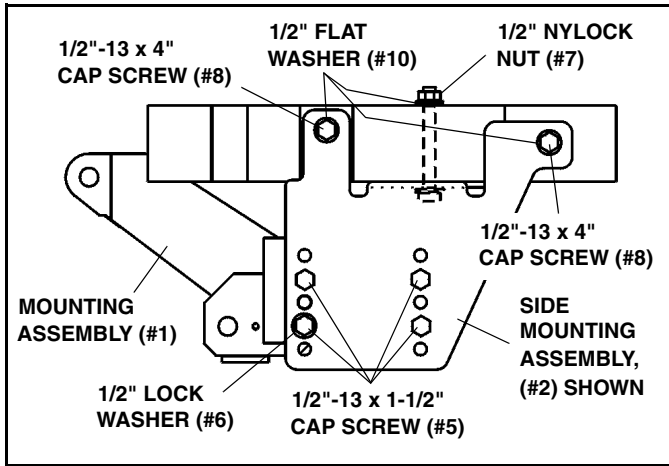

3. Secure the Side Mounting Assembly loosely to the frame rail, installing (2) 1/2" x 4" Cap Screws (#8) and (2) 1/2" Flat Washers (#10) from the outside and securing at the inside of the frame rail with (2) Shim Plates (#4) and (2) 1/2" Nylock Nuts (#7). Install (1) 1/2"-13 x 5" Cap Screw (#9) and (1) 1/2" Flat Washer (#10) from the bottom, through the flange and the frame rail, securing with (1) 1/2" Flat Washer (#10) and (1) 1/2" Nylock Nut (#7). Do not tighten at this time.
4. Repeat procedure for other Side Mounting Assembly.
5. Install the Mounting Assembly (#1) using (8) 1/2"-13 X 1-1/2" Cap Screws (#5), (2) 1/2" Lock Washers (#6) (for the threaded holes) and (6) 1/2" Nylock Nuts (#7).

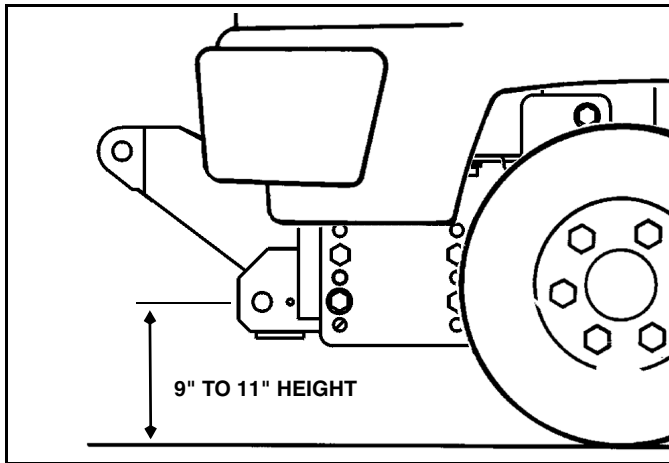

**IMPORTANT:** Height from the center of the lower Plow mounting holes on the Subframe to the ground should be between 9" and 11" to insure proper operation.

6. Using the Torque Specification Chart provided, torque all Cap Screws.

TORQUE SPECIFICATIONS FOR STANDARD MACHINE HARDWARE					
Bolt Size	GR.2 Dry	GR.5 Dry	GR.8 Dry	Metric Size	GR.8.8 Dry
1/4"	66*	9	12	M8	17
5/16"	11	17	25	M10	35
3/8"	20	30	45	M12	60
7/16"	32	50	70	M14	95
1/2"	50	75	110	M16	155
9/16"	70	110	150		
5/8"	100	150	220		
3/4"	175	260	380		
7/8"	170	430	600		
1"	250	640	900		

These torque values are to be used for all hardware. Unless otherwise specified, all torque values must meet this specification.  
All torque values are in Ft.-Lbs unless otherwise stated  
\*In-Lbs

**REMEMBER** After 5 to 10 hours of snowplow usage, re-torque all Cap Screws!

# PARTS LIST

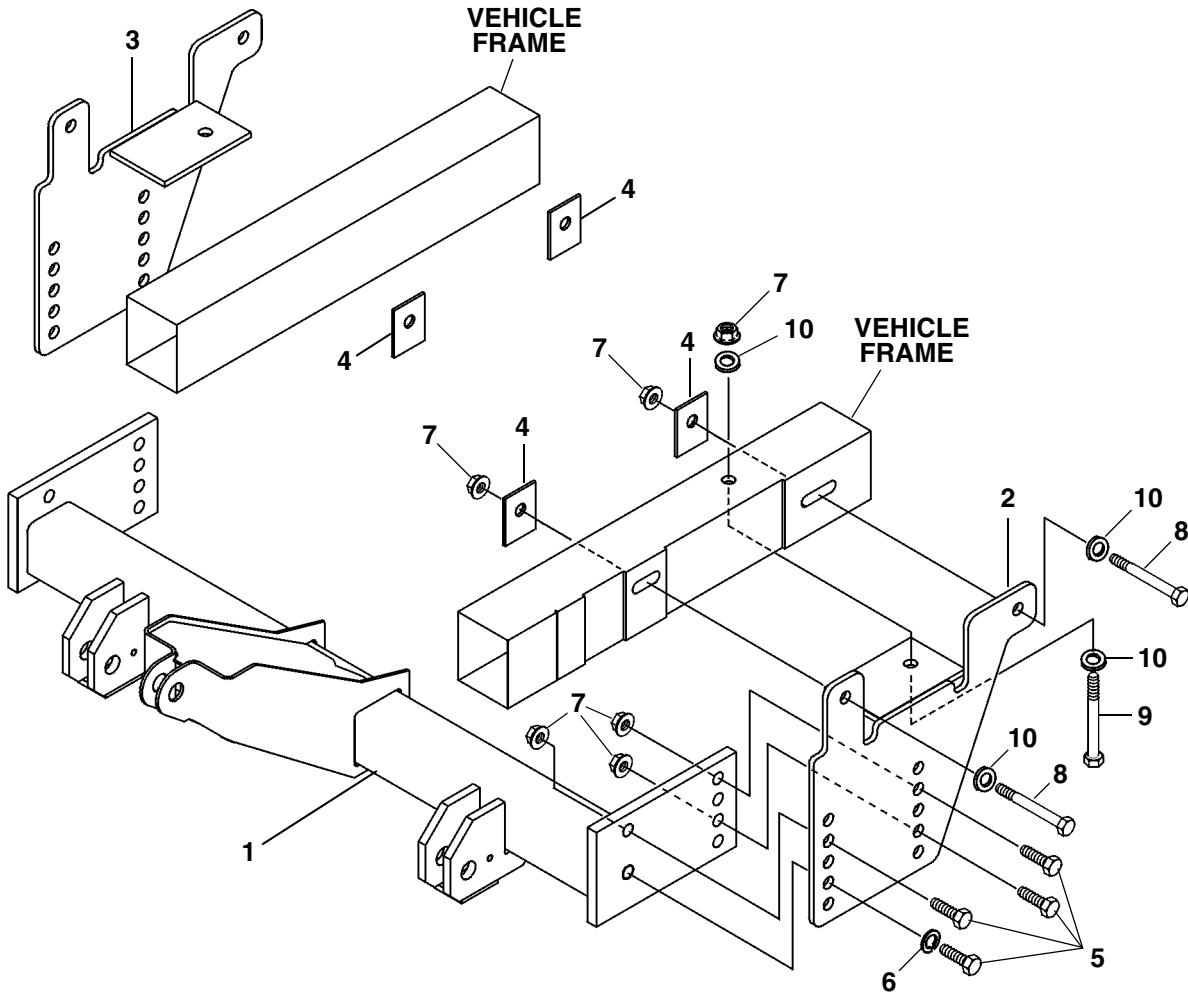

Note: It is recommended that LOCTITE®, or similar thread locking product, be used on ALL mounting hardware (i.e. Nuts, Cap Screws, Bolts, etc.).

ITEM	PART NO.	DESCRIPTION	QTY.
1	96106919	Mounting Assembly .....	1
2	96106923	Side Mounting Assembly, LH .....	1
3	96106924	Side Mounting Assembly, RH .....	1
4	96103283	Plate, Shim .....	4
5	98009010	Cap Screw, Hex head, 1/2"-13 x 1-1/2" .....	8
6	98009012	Washer, Lock, 1/2" .....	2
7	98009013	Nut, Hex Nylock, 1/2" .....	12
8	98009195	Cap Screw, Hex Head, 1/2"-13 x 4" .....	4
9	98009055	Cap Screw, Hex Head, 1/2"-13 x 5" .....	2
10	98009011	Washer, Flat, 1/2" .....	8

SNO-WAY® INTERNATIONAL, INC.

**SNO-WAY**  
SNOW & ICE CONTROL EQUIPMENT

Hartford, WI 53027 USA  
Website: [www.snoway.com](http://www.snoway.com)  
©2005 Sno-Way® International