

# **SNO-WAY**®

**SNOW & ICE CONTROL EQUIPMENT**

## **ASSEMBLY & INSTALLATION INSTRUCTIONS**

**FOR  
SUBFRAME COMPONENTS PACKAGE 99100746**

**TO FIT  
2005 - 2023 TOYOTA TACOMA 4X4**

Sno-Way®, Down Pressure® and EIS® are registered trademarks of Sno-Way International, Inc.  
ProControl™, MegaBlade™, V-Wing™, E-Z Switch™, Revolution™, MaxAdjust™, SpeedLock™, and QuickJack™  
are trademarks of Sno-Way International, Inc.

©2024 Sno-Way® International

97101189E



1. **THINK SAFETY, ALWAYS WEAR SAFETY GLASSES WHEN PERFORMING THE OPERATIONS PRESCRIBED IN THESE INSTRUCTIONS**
2. **READ ALL INSTRUCTIONS CAREFULLY BEFORE ATTEMPTING INSTALLATION**
3. **BEFORE BEGINNING WORK MAKE SURE TO SET PARKING BRAKE AND CHOCK WHEELS**



## MINIMUM VEHICLE RECOMMENDATIONS

Heavy Duty Alternator

Heavy Duty Battery

*NOTE: On some vehicles it may be necessary to use a form of load booster to decrease the vehicle's front suspension sag with the snow plow in place. This can be accomplished with the use of supplementary air bags, booster springs, or similar load boosting devices. Since there are different load boosting devices available, it will up to the customer/end user to decide and purchase the product to suit the application, and not the responsibility of Sno-Way International, Inc.*

## ASSEMBLY TOOLS NEEDED

Drill Bits	17/32"
Impact Sockets	7/16" – 1-3/8"
Impact Sockets Metric	10mm – 19mm
Wrenches	7/16" – 1-3/8"
Torque Wrench	
Clamping Device ("C", Bar, type device...)	

## INSTALLATION NOTES

1. **Unless otherwise specified, mount all Subframe Components to vehicle before tightening any hardware.**
2. **It is recommended that LOCTITE®, or similar thread locking product, be used on ALL mounting hardware (i.e. Nuts, Cap Screws, Bolts, etc.).**
3. Vehicle should be parked on a level surface with a normal vehicle load on the FRONT suspension.
4. Items in parentheses ( ) refer to quantity required for this step. Items in parentheses with a pound sign (#) indicate the part number as found in the parts list on the last page of this document.  
Example: (2) 1/2" Plain Washers (#3).
5. It may be necessary to relocate license plate holder. Check state and local laws for placement, if needed.

## MOUNTING INSTRUCTIONS

1. Remove the tow hook / tie down bracket (passenger side only) and the end caps (both sides) from the front crossmember of the vehicle frame. Retain parts and fasteners for re-installation if the subframe is removed from the vehicle.
2. If the vehicle is equipped with the optional aluminum front skid plate, remove and retain it and fasteners for re-installation if the subframe is removed.
3. Install the Mounting Weldment (#1) by following the steps below:
  - a. Slide the Mounting Weldment into place with the rear arms behind the front crossmember of the vehicle.
  - b. Align the bottom holes in the front of the mount with the end cap holes in the bottom of the front crossmember, then clamp in place.

- c. Place (1) 1/2" Plain Washer (#3) onto (1) 1/2"-13 x 1-1/2" Handle Bolt Weldment (#2) and pass it up through the bottom of the vehicle front crossmember. Secure using (1) 1/2" Plain Washer (#3) and (1) 1/2" Locknut (#4). Finger tighten and repeat on the other side.
- d. Align the slots in the rear arms with the existing frame hole. Place (1) 1/2" Plain Washer (#3) onto (1) 1/2"-13 x 1-1/2" Handle Bolt Weldment (#2) and pass it through the access slot just behind the exiting hole in the vehicle frame rail. Secure using (1) 1/2" Plain Washer (#3) and (1) 1/2" Locknut (#4). Finger tighten and repeat on the other side.
- e. Using the holes in the front of the Mounting Weldment as a template, drill a 17/32" hole into the front of the front crossmember at each side of the vehicle. Place (1) 1/2" Plain Washer (#3) onto (1) 1/2"-13 x 1-1/2" Handle Bolt Weldment (#2), and insert into the end of the front crossmember and out through the drilled 17/32" hole. Secure using (1) 1/2" Locknut (#4) per side.
4. Tighten all hardware using the torque specification chart provided.

**IMPORTANT: Height from the center of the lower Plow mounting holes on the Subframe to the ground should be between 8" and 10" to insure proper operation.**

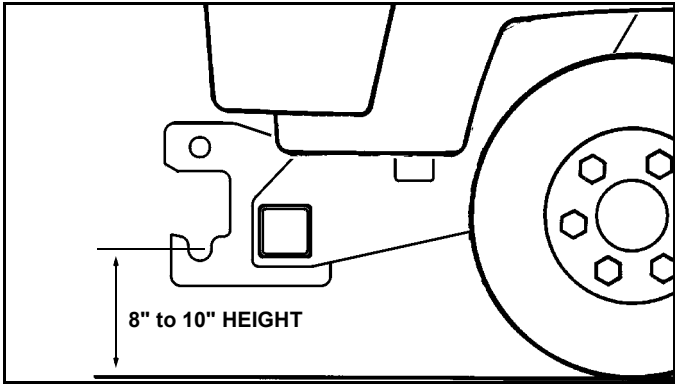

5. Bend or cut the ends of any bolt handles protruding out of the truck frame to prevent contact with any vehicle or plow parts.

TORQUE SPECIFICATIONS FOR STANDARD MACHINE HARDWARE					
Bolt Size	GR.2 Dry	GR.5 Dry	GR.8 Dry	Metric Size	GR.8.8 Dry
1/4"	66*	9	12	M8	17
5/16"	11	17	25	M10	35
3/8"	20	30	45	M12	60
7/16"	32	50	70	M14	95
1/2"	50	75	110	M16	155
9/16"	70	110	150		
5/8"	100	150	220		
3/4"	175	260	380		
7/8"	170	430	600		
1"	250	640	900		

Note: These torque values are to be used for all hardware. Unless otherwise specified, all torque values must meet this specification.  
 Note: All torque values are in Ft.-Lbs unless otherwise stated  
 Note: \*In-Lbs

**REMEMBER After 5 to 10 hours of snowplow usage, re-torque all Cap Screws!**

# PARTS LIST

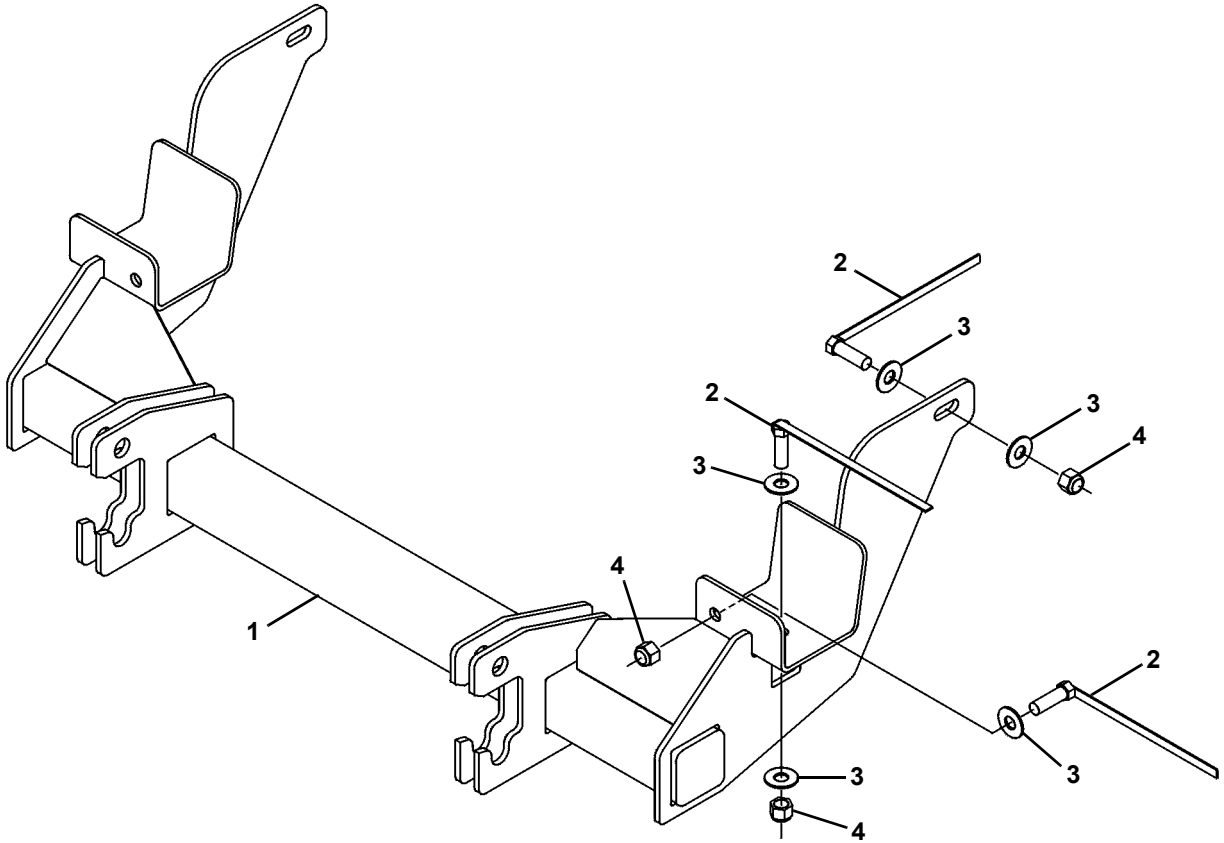

Note: It is recommended that LOCTITE®, or similar thread locking product, be used on ALL mounting hardware (i.e. Nuts, Cap Screws, Bolts, etc.).

ITEM	PART NO.	DESCRIPTION	QTY.
1		Mounting Weldment .....	1
2		Weldment, Handle Bolt, 1/2"-13 x 1-1/2" .....	6
3		PW, 1/2" .....	10
4		LN, 1/2"-13 .....	6
5	96108427	Kit, HDWE (Includes Items 2-4) (Not Shown) .....	1

SNO-WAY® INTERNATIONAL, INC.



Hartford, WI 53027 USA  
 Website: [www.snoway.com](http://www.snoway.com)  
 ©2024 Sno-Way® International