



**Assembly  
&  
Installation Instructions**

**FOR  
VEHICLE MOUNT KIT 99100876  
USING  
VEHICLE CENTER MEMBER 99100890**

**TO FIT  
97 - 03 FORD F150  
97 - 03 FORD F250 (LIGHT DUTY)  
97 - 03 FORD EXPEDITION**



1. **THINK SAFETY, ALWAYS WEAR SAFETY GLASSES WHEN PERFORMING THE OPERATIONS PRESCRIBED IN THESE INSTRUCTIONS**
2. **READ ALL INSTRUCTIONS CAREFULLY BEFORE ATTEMPTING INSTALLATION**
3. **BEFORE BEGINNING WORK MAKE SURE TO SET PARKING BRAKE AND CHOCK WHEELS**



## MINIMUM VEHICLE RECOMMENDATIONS

Heavy Duty Alternator  
 Heavy Duty Battery  
 Manufacturer's Snow Plow Package

*NOTE: On some vehicles it may be necessary to use a form of load booster to decrease the vehicle's front suspension sag with the snow plow in place. This can be accomplished with the use of supplementary air bags, booster springs, or similar load boosting devices. Since there are different load boosting devices available, it will up to the customer/end user to decide and purchase the product to suit the application, and not the responsibility of Sno-Way International, Inc.*

## ASSEMBLY TOOLS NEEDED

Drill Bits 1/4", 17/32"  
 Impact Sockets 7/16" – 1-3/8"  
 Wrenches 7/16" – 1-3/8"  
 Torque Wrench  
 Rat Tail Pry Bar  
 Center Punch and Hammer  
 Clamping Devices ("C", Bar, type device .....)  
 Hacksaw

## INSTALLATION NOTES

1. **Unless otherwise specified, mount all Vehicle Mount Kit Components to vehicle before tightening any hardware.**
2. **It is recommended that LOCTITE®, or similar thread locking product, be used on ALL mounting hardware (i.e. Nuts, Cap Screws, Bolts, etc.).**
3. Vehicle should be parked on a level surface with a normal vehicle load on the FRONT suspension.
4. Items in parentheses ( ) refer to quantity required for this step. Items in parentheses with a pound sign (#) indicate the part number as found in the parts list on the last page of this document.  
 Example: (10) Washer, Lock, 1/2" (#8).
5. It maybe necessary to relocate license plate holder. Check state and local laws for placement, if needed.

## MOUNTING INSTRUCTIONS

### F-250 (Light Duty) only:

1. Remove splashguard and remaining hardware from the underside of the vehicle. Retain hardware for future re-installation if the Vehicle Mount Kit is removed.
2. Relocate the license plate if required. (See installation note #5.)
3. Remove tow hooks and hardware. Retain for re-installation if the Vehicle Mount Kit is removed.

### F-150 and F-250 (Light Duty):

1. Remove the vehicle front bumper assembly. Retain hardware for re-installation of the bumper.
2. Remove air dam from the bumper, with hardware, and retain for future use if Vehicle Mount Kit is removed.
3. Remove tow hooks and hardware.

4. To install Side Weldment LH (#2) and RH (#3) do the following on both sides:  
 Insert (1) Nut Plate (#5) inside the vehicle frame and align the holes with the tow hook holes.  
 Align the front bottom holes in the Side Weldments with the tow hook mounting holes and the nut plate holes. Secure loosely using (4) 1/2"-13 x 2" Cap Screws (#8), (4) 1/2" Lock Washers (#10) and (4) 1/2" Flat Washers (#11), two of each per side.  
 Using the rest of the holes in the Side Weldments, LH and RH, as a template (1 on the front side of the frame rail, and 2 top rear holes), center punch and drill 1/4" pilot holes through the outside of the vehicle frame rail.  
 Move the brackets out of the way, and re-drill pilot holes to 17/32". Move brackets back into place.  
 Insert Nut Plates (#4), one per side, into the front of the frame rail, and secure the 3 rear holes in each Side Weldment using (3) 1/2"-13 x 1-1/2" Cap Screws (#7) and (3) Lock Washers (#10). Insert Nut Plates (#6), one per side, into the front of the frame rail and secure the front-most newly drilled hole using (1) 1/2"-13 x 1-1/2" Cap Screw (#7) and (1) Lock Washer (#10).
5. Assemble the Vehicle Center Member (#1) to the Side Weldments, LH and RH. Align the holes in the Weldments with the holes in the Vehicle Center Member. Secure using (8) 1/2"-13 x 1-1/2" Cap Screws (#7), (2) 1/2" Lock Washers (#10) on bolts used in the threaded holes, and (6) Nylock Nuts (#9).
6. Using the torque specification chart provided, torque all Cap Screws.
7. Re-install the bumper.

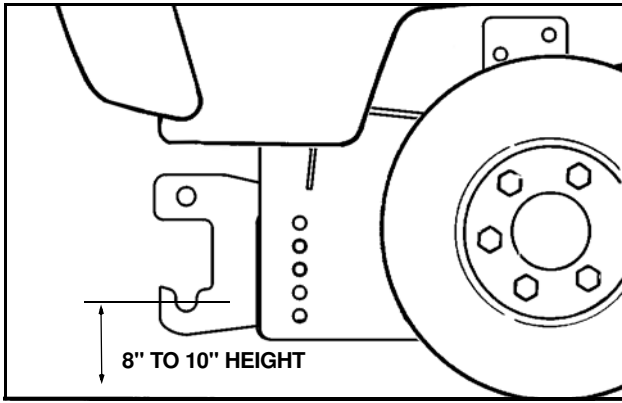

**IMPORTANT:** Height from the center of the lower Plow Mounting holes on the Vehicle Mount Kit to the ground should be between 8" and 10" to insure proper operation.

TORQUE SPECIFICATIONS FOR STANDARD MACHINE HARDWARE					
Bolt Size	GR.2 Dry	GR.5 Dry	GR.8 Dry	Metric Size	GR.8.8 Dry
1/4"	66*	9	12	M8	17
5/16"	11	17	25	M10	35
3/8"	20	30	45	M12	60
7/16"	32	50	70	M14	95
1/2"	50	75	110	M16	155
9/16"	70	110	150		
5/8"	100	150	220		
3/4"	175	260	380		
7/8"	170	430	600		
1"	250	640	900		

Note: These torque values are to be used for all hardware. Unless otherwise specified, all torque values must meet this specification.  
 Note: All torque values are in Ft.-Lbs unless otherwise stated  
 Note: \*In-Lbs

**REMEMBER** After 5 to 10 hours of snowplow usage, re-torque all Cap Screws!

# PARTS LIST

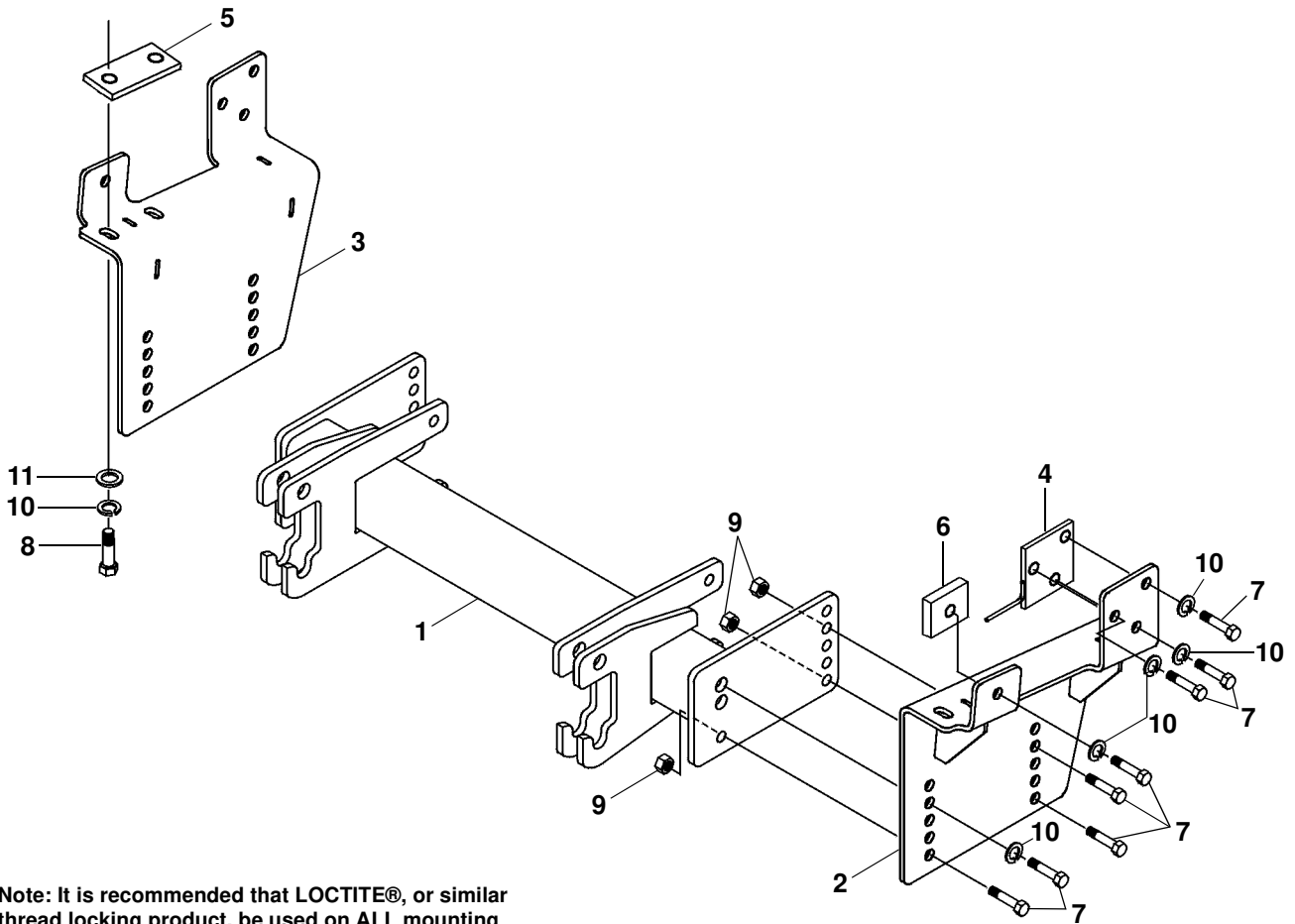

Note: It is recommended that LOCTITE®, or similar thread locking product, be used on ALL mounting hardware (i.e. Nuts, Cap Screws, Bolts, etc.).

ITEM	PART NO.	DESCRIPTION	QTY.
1	99100890	Vehicle Center Member .....	1
2		Side Weldment, LH .....	1
3		Side Weldment, RH.....	1
4		Nut Plate Assembly .....	2
5		Nut Plate.....	2
6		Nut Plate.....	2
7		Cap Screw, Hex Head, 1/2"-13 x 1-1/2" .....	16
8		Cap Screw, Hex Head, 1/2"-13 x 2" .....	4
9		Nut, Nylock, 1/2"-13 .....	6
10		Washer, Lock, 1/2" .....	4
11		Washer, Flat, 1/2" .....	4
12	96109005	Kit, HDWE (Includes Items 4-11) (Not Shown).....	1

SNO-WAY® INTERNATIONAL, INC.



Hartford, WI 53027 USA  
 Website: [www.snoway.com](http://www.snoway.com)  
 ©2020 Sno-Way® International