

SNO-WAY®

SNOW & ICE CONTROL EQUIPMENT

ASSEMBLY & INSTALLATION INSTRUCTIONS

**VEHICLE MOUNT KIT 99100875
USING
VEHICLE CENTER MEMBER 99100890**

**TO FIT
2002 - 2005 DODGE RAM 1500 4X4**

Sno-Way®, Down Pressure® and EIS® are registered trademarks of Sno-Way International, Inc.
ProControl™, MegaBlade™, V-Wing™, E-Z Switch™, Revolution™, MaxAdjust™, SpeedLock™, and QuickJack™
are trademarks of Sno-Way International, Inc.

©2019 Sno-Way® International

97101220E



1. **THINK SAFETY, ALWAYS WEAR SAFETY GLASSES WHEN PERFORMING THE OPERATIONS PRESCRIBED IN THESE INSTRUCTIONS**
2. **READ ALL INSTRUCTIONS CAREFULLY BEFORE ATTEMPTING INSTALLATION**
3. **BEFORE BEGINNING WORK MAKE SURE TO SET PARKING BRAKE AND CHOCK WHEELS**



MINIMUM VEHICLE RECOMMENDATIONS

Heavy Duty Alternator
Heavy Duty Battery

NOTE: On some vehicles it may be necessary to use a form of load booster to decrease the vehicle's front suspension sag with the snow plow in place. This can be accomplished with the use of supplementary air bags, booster springs, or similar load boosting devices. Since there are different load boosting devices available, it will up to the customer/end user to decide and purchase the product to suit the application, and not the responsibility of Sno-Way International, Inc.

ASSEMBLY TOOLS NEEDED

| | |
|-------------------------|----------------|
| Drill Bits | 1/4", 17/32" |
| Impact Sockets | 7/16" – 1-3/8" |
| Impact Sockets, Metric | 10mm - 18mm |
| Wrenches | 7/16" – 1-3/8" |
| Wrenches, Metric | 10mm - 18mm |
| Torque Wrench | |
| Rat Tail Pry Bar | |
| Center Punch and Hammer | |

INSTALLATION NOTES

1. **Unless otherwise specified, mount all Vehicle Mount Kit Components to vehicle before tightening any hardware.**
2. **It is recommended that LOCTITE®, or similar thread locking product, be used on ALL mounting hardware (i.e. Nuts, Cap Screws, Bolts, etc.).**
3. Vehicle should be parked on a level surface with a normal vehicle load on the FRONT suspension.
4. Items in parentheses () refer to quantity required for this step. Items in parentheses with a pound sign (#) indicate the part number as found in the parts list on the last page of this document.
Example: (10) Washer, Lock, 1/2" (#8).
5. It maybe necessary to relocate license plate holder. Check state and local laws for placement, if needed.

Remove the hardware from the front holes, re-install the bumper so that the bumper brackets are between the frame rails and the Front Mounting Weldments and secure again with the original bumper hardware.

4. Install (1) Vehicle Center Member (#1). Secure to the Plate Side (#2) using (4- 2 per side) 1/2" Spacers (#8) between the Front Mounting Weldments and the Vehicle Center Member, (8) 1/2"-13 x 2" Cap Screws (#10), (2) 1/2" Lock Washers (#12) in the threaded holes, and (6) 1/2"-13 Nylock Nut (#11).
5. Install (1) Crossmember Rear Weldment (#4) by aligning the holes in the Crossmember Rear Weldment with the corresponding rear holes (the ones mentioned at the end of step #4) in the Vehicle Center Member, ensuring that the 90 degree angle piece on the Crossmember Rear Weldment should be flush against the vehicle Crossmember on both the horizontal and vertical faces. If needed, clamp in place until the holes that need to be drilled are drilled.

MOUNTING INSTRUCTIONS

1. Remove splash shield from under vehicle. Retain with hardware for future use if subframe is removed.
2. Remove vehicle's front bumper. Retain hardware for reinstallation in step 3.
3. Install the Plate Side (#2) and the Plate Spacer (#3) as follows: Start by aligning the front holes with the bumper mounting holes. Temporarily secure with existing bumper hardware. Using the rear holes as a template, center punch and drill 1/4", then 17/32" holes through the inside of the frame.

Loosen front hardware, then install (2) Handle Bolts (#5) with (2) 1/2" Flat Washers (#13) inside the frame rail, aligned with the drilled holes. Position a Spacer (#6) between the Plate Spacer and the frame rail, align with the drilled holes and secure with (2) 1/2"-13 Nylock Nut (#11).

Use the (4) holes in the Crossmember Rear Weldment as a template, and drill 1/4" pilot holes, then drill to 17/32", through the vehicle Crossmember front and bottom walls. Secure the Crossmember Rear Weldment to the vehicle frame by inserting (4) Handle Bolts (#7) and (4) 1/2" Flat Washers (#13) into the frame Crossmember, then secure with (4) 1/2" x 13 Nylock Nuts (#11).

Finally position the Rear Crossmember Weldment to the Vehicle Center Member and insert (2 - 1 per side) Spacer Plates (#14) between the Vehicle Center Member and Rear Crossmember Weldment. Secure using (6 - 3 per side) 1/2"-13 Nylock Nut (#11).

6. Using the Torque Specification Chart provided, torque all bolts starting at the rear and working forward.

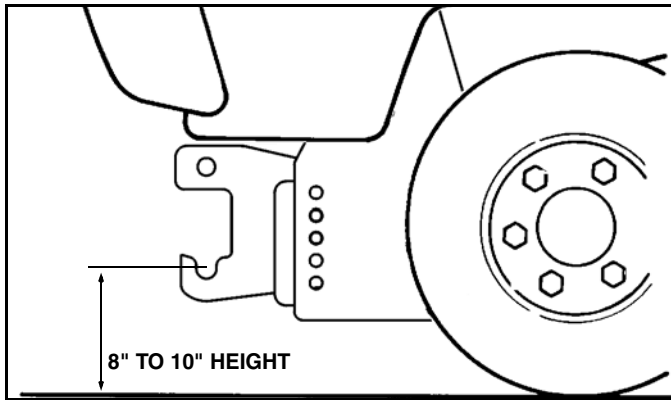

Figure 1

IMPORTANT: Height from the center of the lower Plow Mounting holes on the Vehicle Mount Kit to the ground should be between 8" and 10" to ensure proper operation.

| TORQUE SPECIFICATIONS FOR STANDARD MACHINE HARDWARE | | | | | |
|-----------------------------------------------------|----------|----------|----------|-------------|------------|
| Bolt Size | GR.2 Dry | GR.5 Dry | GR.8 Dry | Metric Size | GR.8.8 Dry |
| 1/4" | 66* | 9 | 12 | M8 | 17 |
| 5/16" | 11 | 17 | 25 | M10 | 35 |
| 3/8" | 20 | 30 | 45 | M12 | 60 |
| 7/16" | 32 | 50 | 70 | M14 | 95 |
| 1/2" | 50 | 75 | 110 | M16 | 155 |
| 9/16" | 70 | 110 | 150 | | |
| 5/8" | 100 | 150 | 220 | | |
| 3/4" | 175 | 260 | 380 | | |
| 7/8" | 170 | 430 | 600 | | |
| 1" | 250 | 640 | 900 | | |

Note: These torque values are to be used for all hardware. Unless otherwise specified, all torque values must meet this specification.
 Note: All torque values are in Ft.-Lbs unless otherwise stated
 Note: *In-Lbs

REMEMBER After 5 to 10 hours of snowplow usage, re-torque all Cap Screws!

PARTS LIST

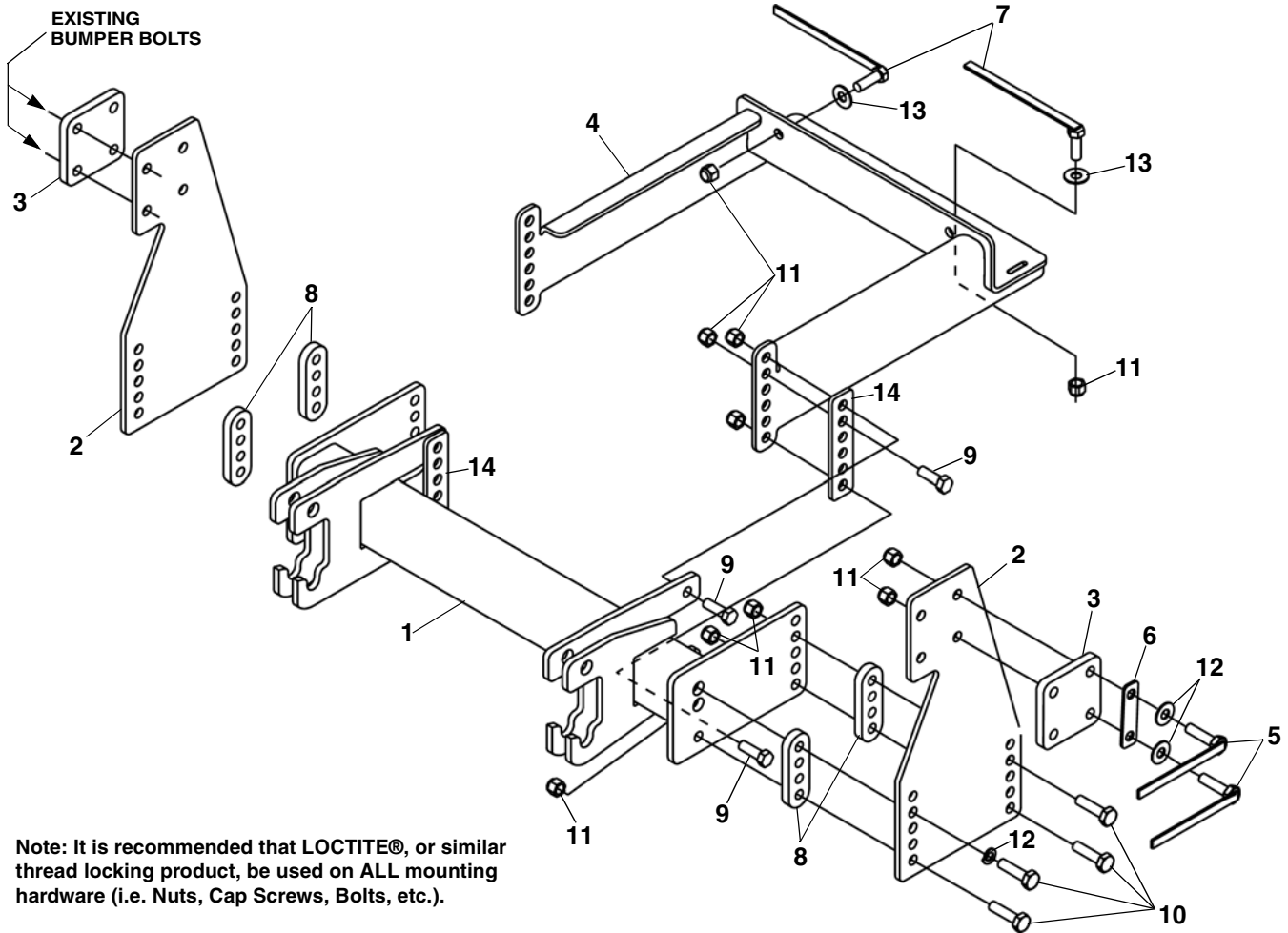

Note: It is recommended that LOCTITE®, or similar thread locking product, be used on ALL mounting hardware (i.e. Nuts, Cap Screws, Bolts, etc.).

| ITEM | PART NO. | DESCRIPTION | QTY. |
|------|----------|------------------------------------------------------|------|
| 1 | 99100890 | Vehicle Center Member | 1 |
| 2 | | Plate Side | 2 |
| 3 | | Plate Spacer | 2 |
| 4 | | Crossmember Rear Weldment | 1 |
| 5 | | Handle Bolt, 1/2"-13 x 2" | 4 |
| 6 | | Spacer, 1/8" | 2 |
| 7 | | Handle Bolt, 1/2"-13 x 1-1/2" | 4 |
| 8 | | Spacer, 1/2" | 4 |
| 9 | | HHCS, 1/2"-13 x 1-1/2" | 6 |
| 10 | | HHCS, 1/2"-13 x 2" | 8 |
| 11 | | LN, 1/2" | 20 |
| 12 | | LW, 1/2" | 2 |
| 13 | | PW, 1/2", B Regular | 8 |
| 14 | | Spacer Plate | 2 |
| 15 | 96109010 | Kit, HDWE (Includes Items 3, 5-14) (Not Shown) | 1 |

SNO-WAY® INTERNATIONAL, INC.



Hartford, WI 53027 USA
 Website: www.snoway.com
 ©2019 Sno-Way® International