

SNO-WAY®

SNOW & ICE CONTROL EQUIPMENT

ASSEMBLY & INSTALLATION INSTRUCTIONS

**MEGABLADE™ VEHICLE MOUNT KIT
99100967**

**TO FIT
2003 - LATER DODGE 2500 - 3500 4X4**

Sno-Way®, Down Pressure® and EIS® are registered trademarks of Sno-Way International, Inc.
ProControl™, MegaBlade™, V-Wing™, E-Z Switch™, Revolution™, MaxAdjust™, SpeedLock™, and QuickJack™
are trademarks of Sno-Way International, Inc.

©2009 Sno-Way® International

97101517B



1. **THINK SAFETY, ALWAYS WEAR SAFETY GLASSES WHEN PERFORMING THE OPERATIONS PRESCRIBED IN THESE INSTRUCTIONS**
2. **READ ALL INSTRUCTIONS CAREFULLY BEFORE ATTEMPTING INSTALLATION**
3. **BEFORE BEGINNING WORK MAKE SURE TO SET PARKING BRAKE AND CHOCK WHEELS**



MINIMUM VEHICLE RECOMMENDATIONS

Heavy Duty Alternator
 Heavy Duty Battery
 Manufacturers Snow Plow Package

NOTE: On some vehicles it may be necessary to use a form of load booster to decrease the vehicle's front suspension sag with the snow plow in place. This can be accomplished with the use of supplementary air bags, booster springs, or similar load boosting devices. Since there are different load boosting devices available, it will up to the customer/end user to decide and purchase the product to suit the application, and not the responsibility of Sno-Way International, Inc.

ASSEMBLY TOOLS NEEDED

Drill Bits	1/4", 17/32", 21/32"
Impact Sockets	7/16" – 1-3/8"
Impact Sockets, Metric	10mm – 18mm
Wrenches	7/16" – 1-3/8"
Wrenches, Metric	10mm - 18mm
Torque Wrench	
Center Punch and Hammer	
Rat Tail Pry Bar	
Rubber Bands	

INSTALLATION NOTES

NOTE: Items designated "DS" refer to the Driver Side or Left Hand Side of the vehicle. Items designated "PS" refer to the Passenger Side or Right Hand Side of the vehicle.

1. **Unless otherwise specified, mount all Subframe Components to vehicle before tightening any hardware.**
2. **It is recommended that LOCTITE®, or similar thread locking product, be used on ALL mounting hardware (i.e. Nuts, Cap Screws, Bolts, etc.).**
3. Vehicle should be parked on a level surface with a normal vehicle load on the FRONT suspension.
4. Items in parentheses () refer to quantity required for this step. Items in parentheses with a pound sign (#) indicate the part number as found in the parts list on the last page of this document.
 Example: (2) 5/8" - 11 x 2" Cap Screws (#10).
5. It maybe necessary to relocate license plate holder. Check state and local laws for placement, if applicable.

MOUNTING INSTRUCTIONS

1. Remove the mounting hardware connecting the truck bumper to the driver side of the truck frame.

NOTE: It may be necessary to remove radiator or inter-cooler fasteners. Some vehicles have brackets that are bolted on and some are welded secure. If you have a version that is welded, grind area clear for sub-frame clearance (Refer to photo below).

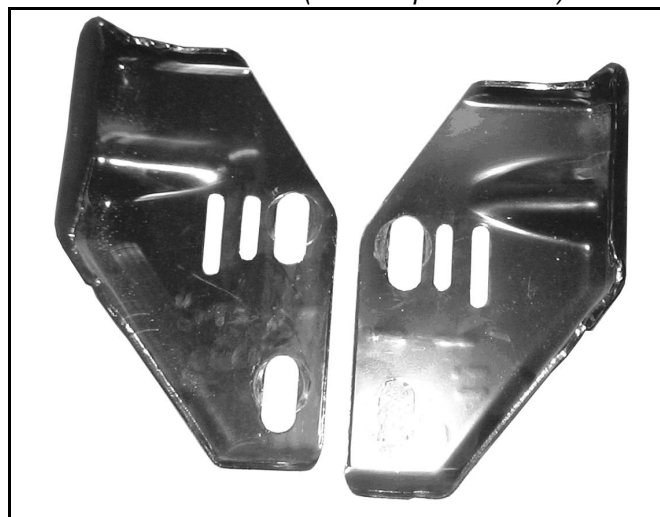

Note: To help installation go smoother use a 23/32 drill bit in the frame rails of the truck to open the hole enough to allow the U bolt to slip into the frame and back out. At this point use a rubber band between the bolts coming through the frame to help hold the U bolt in place so it does not slip into the frame.



2. Place Weldment, Side, DS (#2) up against the bumper bracket, aligning the two front holes in the Weldment, Side, DS with the bumper mounting holes. Temporarily secure using (2) 1/2" – 13 x 5" Cap Screws (#13) and (2) 1/2" – 13 Nylock Nuts (#15). Using the rear holes in Weldment, Side, DS as a template, center punch and drill 1/4" pilot holes. Remove the Weldment, Side, DS and enlarge the 1/4" pilot holes to 17/32". It may be necessary to open one of the holes further to accommodate the U-bolt (#16).

IMPORTANT: DO NOT drill through both sides of the frame rail.

3. Repeat Step 2 on the passenger side of the truck to install the Weldment, Side, PS (#3).
4. Remove Weldment, Side, DS (#2), PS (#3), and the truck bumper. Re-align the Weldment, Side, DS (#2) with the previously drilled holes in the left side of the frame. For both DS and PS Weldment installation perform the following steps:
 - a. Install (2) 1/2" - 13 x 5" Cap Screws (#13), (4) 1/2" Flat Washers (#14) (2 on each side of frame), and (2) 1/2" - 13 Nylock Nuts (#15) through Weldment, Side, DS (#2) and the truck frame securing hardware loosely with Nylock Nuts.
 - b. Install (1) 1/2" U-Bolt (#16) (Hint: To insure the bolt does not fall into the frame hold it in place with a rubber band), (2) 1/2" Flat Washers (#14) and (2) 1/2" - 13 Nylock Nuts (#15), securing hardware loosely with Nylock Nuts.
 - c. Assemble the Weldment, Rear, DS (#4) and PS (#5) onto the rear two holes in the Weldment, Side, DS and PS (#2 and #3).
 - d. Secure using (2) 1/2" - 13 x 1-1/2" Cap Screws (#17) and (2) 1/2" - 13 Nylock Nuts (#15). Position the rear mount supports of the Rear Weldments so they contact the bottom and side of the frame rails. Use the rear mounting holes as a template, then center punch and drill 1/4" pilot holes through frame rail in each position.
 - e. Drop the Rear Weldments out of the way and re-drill the pilot holes to 21/32".
 - f. Install Weldment, Rear, DS (#4) and PS (#5) using (1) 5/8" - 11 x 4" (#10), (1) 5/8" Flat Washer (#11), and (1) 5/8" Nylock Nut (#12) per side.
5. Install the VRM (Vehicle Receiver Member [#1] found in Power Pack Assembly) to the DS and PS Side Weldments using (6) 5/8"-11 x 1-3/4" Cap Screw (#8), (2) 5/8"-11 x 2" Cap Screw (#18 - in holes with the added washer welded to the side bracket) and (8) 5/8" Hardened Washers (#9) securing hardware loosely.

6. With all components in place, tighten all hardware. The mounting hardware for the VRM should be tightened first followed by the Weldment, Side hardware and finally the Weldment, Rear hardware.

IMPORTANT: DO NOT over-tighten the upper mounting hardware for the Rear Weldments, as over-tightening could crush the frame rails!

7. Using the torque specification chart provided, torque all cap screws.

TORQUE SPECIFICATIONS FOR STANDARD MACHINE HARDWARE					
Bolt Size	GR.2 Dry	GR.5 Dry	GR.8 Dry	Metric Size	GR.8.8 Dry
1/4"	66*	9	12	M8	17
3/8"	20	30	45	M12	60
1/2"	50	75	110	M16	155
5/8"	100	150	220		
7/8"	170	430	600		

Note: These torque values are to be used for all hardware. Unless otherwise specified, all torque values must meet this specification.
 Note: All torque values are in Ft.-Lbs unless otherwise stated
 Note: *In-Lbs

REMEMBER: After 5 to 10 hours of snowplow usage, re-torque all Cap Screws!

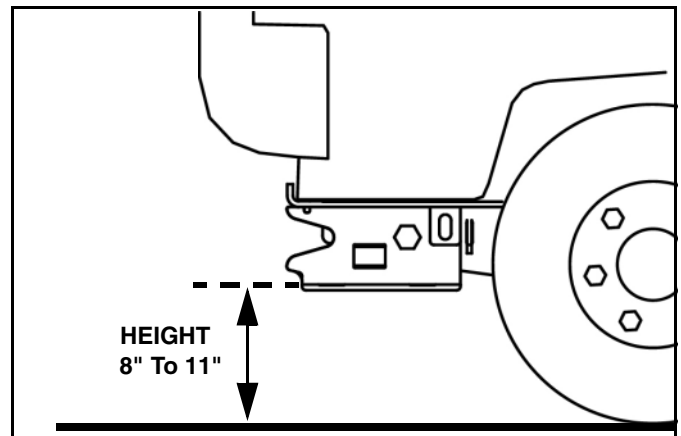

IMPORTANT: Height from the bottom of the VRM to the ground should be between 8" and 11" to ensure proper operation.

PARTS LIST

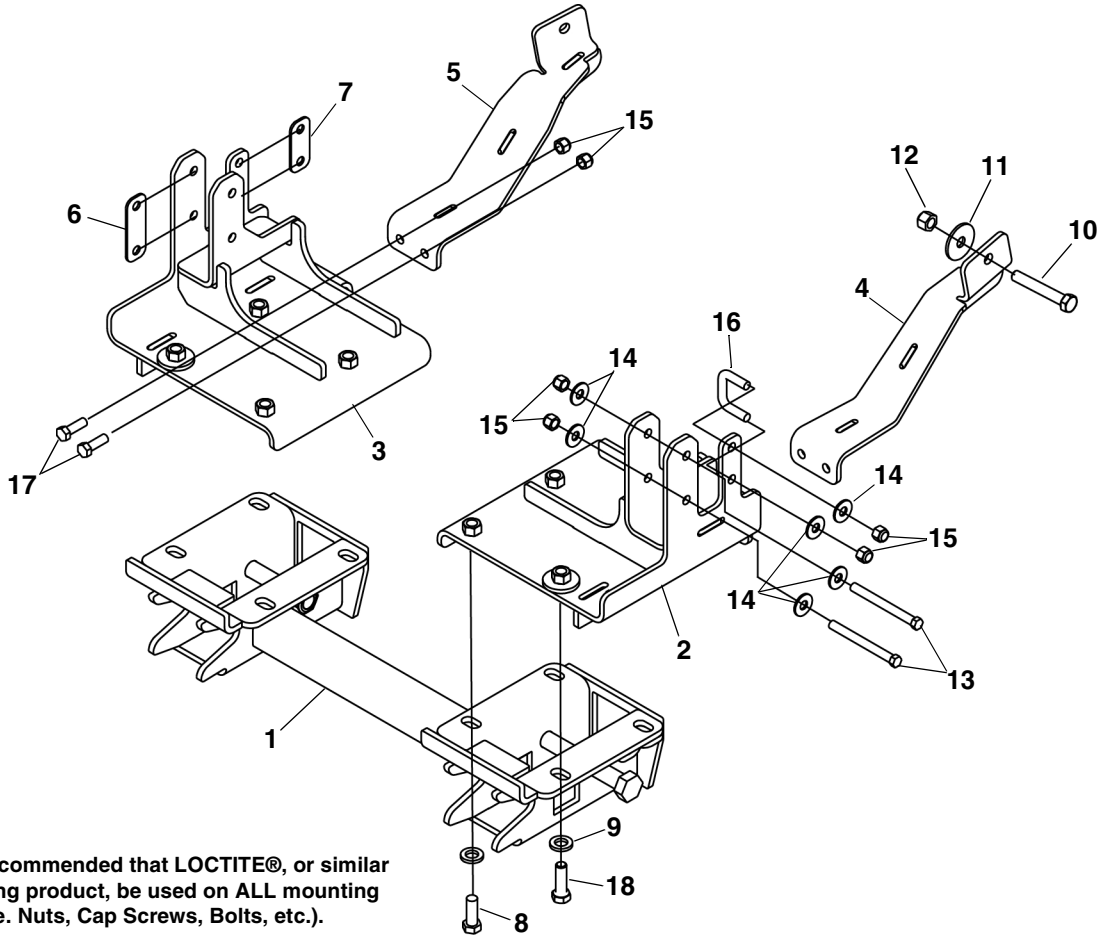

Note: It is recommended that LOCTITE®, or similar thread locking product, be used on ALL mounting hardware (i.e. Nuts, Cap Screws, Bolts, etc.).

ITEM	PART NO.	DESCRIPTION	QTY.
1	96112795*	Weldment, VRM (included in power pack)	1
2	96112928*	Side Weldment, DS.....	1
3	96112929*	Side Weldment, PS.....	1
4	96112045*	Weldment Rear, DS	1
5	96112046*	Weldment Rear, PS.....	1
6	96112348*	Plate Shim, Front	2
7	96112349*	Plate Shim, Rear.....	2
8	98100445	Hex Head Cap Screw, 5/8"-11x1-3/4"	6
9	98100446	Flat Washer, 5/8", .195/.170 Thick, Hardened	8
10	98009194	Hex Head Cap Screw, 5/8"-11x4"	2
11	98100107	Flat Washer, 5/8" A Wide	2
12	98009038	Lock Nut, 5/8" -11, Nylock Insert.....	2
13	98009043	Hex Head Cap Screw, 1/2"-13x5"	4
14	98100176	Flat Washer, 1/2" Hardened.....	12
15	98009013	Lock Nut, 1/2"-13, Nylock Insert.....	12
16	98100271	U-Bolt, 1/2"	2
17	98009010	Hex Head Cap Screw, 1/2"-13x1-1/2"	4
18	98009041	Hex Head Cap Screw, 5/8"-11x2"	2

* Not Available As a Service Part

SNO-WAY® INTERNATIONAL, INC.

SNO-WAY
SNOW & ICE CONTROL EQUIPMENT

Hartford, WI 53027 USA
Website: www.snoway.com
©2009 Sno-Way® International