

SNO-WAY®

SNOW & ICE CONTROL EQUIPMENT

ASSEMBLY & INSTALLATION INSTRUCTIONS

**VEHICLE MOUNT KIT 99101132
AND
VEHICLE CENTER MEMBER 96114780**

TO FIT
2011 - 2020 John Deere Gator™ XUV 625i
2011 - 2024 John Deere Gator™ XUV 825, 855d



©2024 Sno-Way® International

97101821B



1. THINK SAFETY, ALWAYS WEAR SAFETY GLASSES WHEN PERFORMING THE OPERATIONS PRESCRIBED IN THESE INSTRUCTIONS
2. READ ALL INSTRUCTIONS CAREFULLY BEFORE ATTEMPTING INSTALLATION
3. BEFORE BEGINNING WORK MAKE SURE TO SET PARKING BRAKE AND CHOCK WHEELS



ASSEMBLY TOOLS NEEDED

Drill Bits	1/4" - 17/32"
Impact Sockets	7/16" - 1-3/8"
Wrenches	7/16" - 1-3/8"
Torque Wrench	
Rat Tail Pry Bar	
Center Punch and Hammer	
C-Clamp	
Screwdrivers	

INSTALLATION NOTES

1. Vehicle should be parked on a level surface with a normal vehicle load on the FRONT suspension.
2. On some vehicles it may be necessary to raise or stiffen the suspension to decrease the vehicles front suspension sag with the snow plow in place.
3. Unless otherwise specified, mount all Vehicle Mount Kit Components to vehicle before tightening any hardware.
4. It is recommended that LOCTITE®, or similar thread locking product, be used on ALL mounting hardware (i.e. Nuts, Cap Screws, Bolts, etc.).
5. Items in parentheses () refer to quantity required for this step. Items in parentheses with a pound sign (#) indicate the part number as found in the parts list on the last page of this document.
Example: (2) 1/2" Lock Washers (#9).

MOUNTING INSTRUCTIONS

1. Remove front and rear bolts from bottom skid plate.
2. Drill both front skid plate holes to 13/32" (or 7/16" if a 13/32" drill bit is not available).
3. Position bottom bracket (#6) under bottom skid plate. Insert the original two Gator bolts previously removed in the rear holes and (2) 3/8"-16 x 1-1/4" bolts (#10) in the front holes. Loosely secure with (2) 3/8-16 lock nuts (#9).

4. Remove two skid plate bolts from the front of the Gator. Place DS (#3) and PS (#2) front brackets on the front of the Gator and loosely secure each with (1) M10-1.5 x 30 bolt (#11) and original Gator nut.

NOTE: Bottom of the front brackets (#2 & 3) should be to the outside of the bottom bracket.

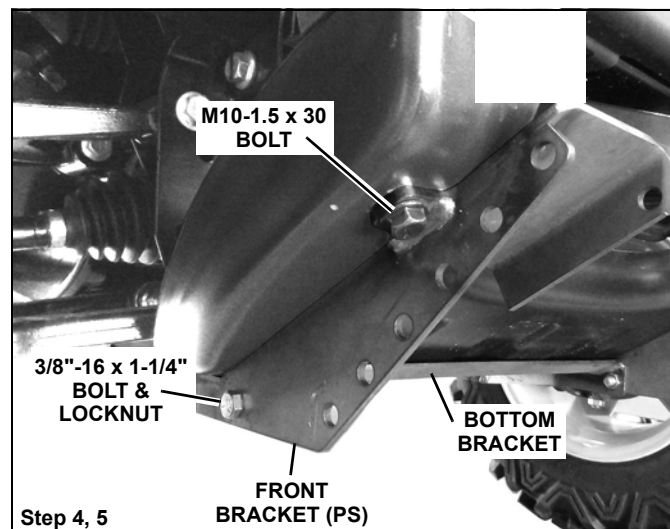
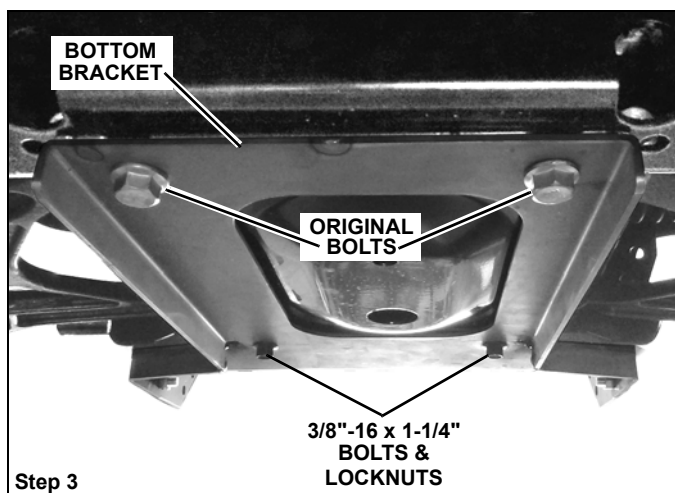

5. Loosely secure each front bracket (#2 & 3) to the bottom bracket (#6) with (2) 3/8-16 X 1-1/4" bolts (#10) and (2) 3/8"-16 locknuts (#9).

6. Loosely secure the DS front bracket (#3) and DS top bracket (#5) together with a (1) 3/8-16 X 1-1/4" bolt (#10) and (1) 3/8"-16 locknut (#9).

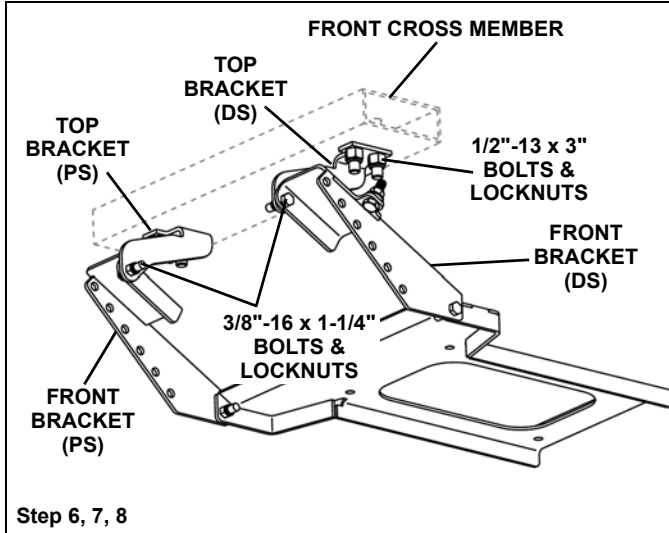

7. Loosely secure the PS front bracket (#2) and PS top bracket (#4) together with a (1) 3/8-16 X 1-1/4" bolt (#10) and (1) 3/8"-16 locknut (#9).
8. Loosely secure the DS (#5) and PS (#6) top brackets to the bottom of the Gator front cross member with (2) 1/2"-13 x 3" bolts (#7) and (2) 1/2"-13 lock nuts (#8) each.

NOTE: The top brackets go to the inside of the front brackets.

9. Position the UTV Mount (#1) on the machine. Align the Mount holes with both front brackets (#3 & 4) to provide an 11" to 12" height between the lower pin slots and the ground.

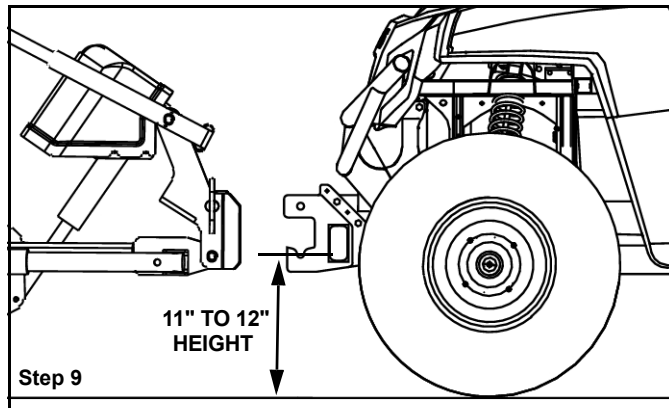

IMPORTANT: Height from the bottom of the lower pin slots on the UTV Mount to the ground should be between 11" and 12" to ensure proper operation.

10. Loosely secure the UTV Mount (#1) to both front brackets (#3 & 4) using (6) 3/8"-16 x 1-1/4" bolts (#7) and (6) 3/8" locknuts (#11).

11. Tighten all hardware using the Torque Specification Chart provided.

TORQUE SPECIFICATIONS FOR STANDARD MACHINE HARDWARE					
Bolt Size	GR.2 Dry	GR.5 Dry	GR.8 Dry	Metric Size	GR.8.8 Dry
1/4"	66*	9	12	M8	17
5/16"	11	17	25	M10	35
3/8"	20	30	45	M12	60
7/16"	32	50	70	M14	95
1/2"	50	75	110	M16	155
9/16"	70	110	150		
5/8"	100	150	220		
3/4"	175	260	380		
7/8"	170	430	600		
1"	250	640	900		

These torque values are to be used for all hardware. Unless otherwise specified, all torque values must meet this specification.
All torque values are in Ft.-Lbs unless otherwise stated
*In-Lbs

REMEMBER After 5 to 10 hours of snowplow usage, re-torque all hardware!

PARTS LIST

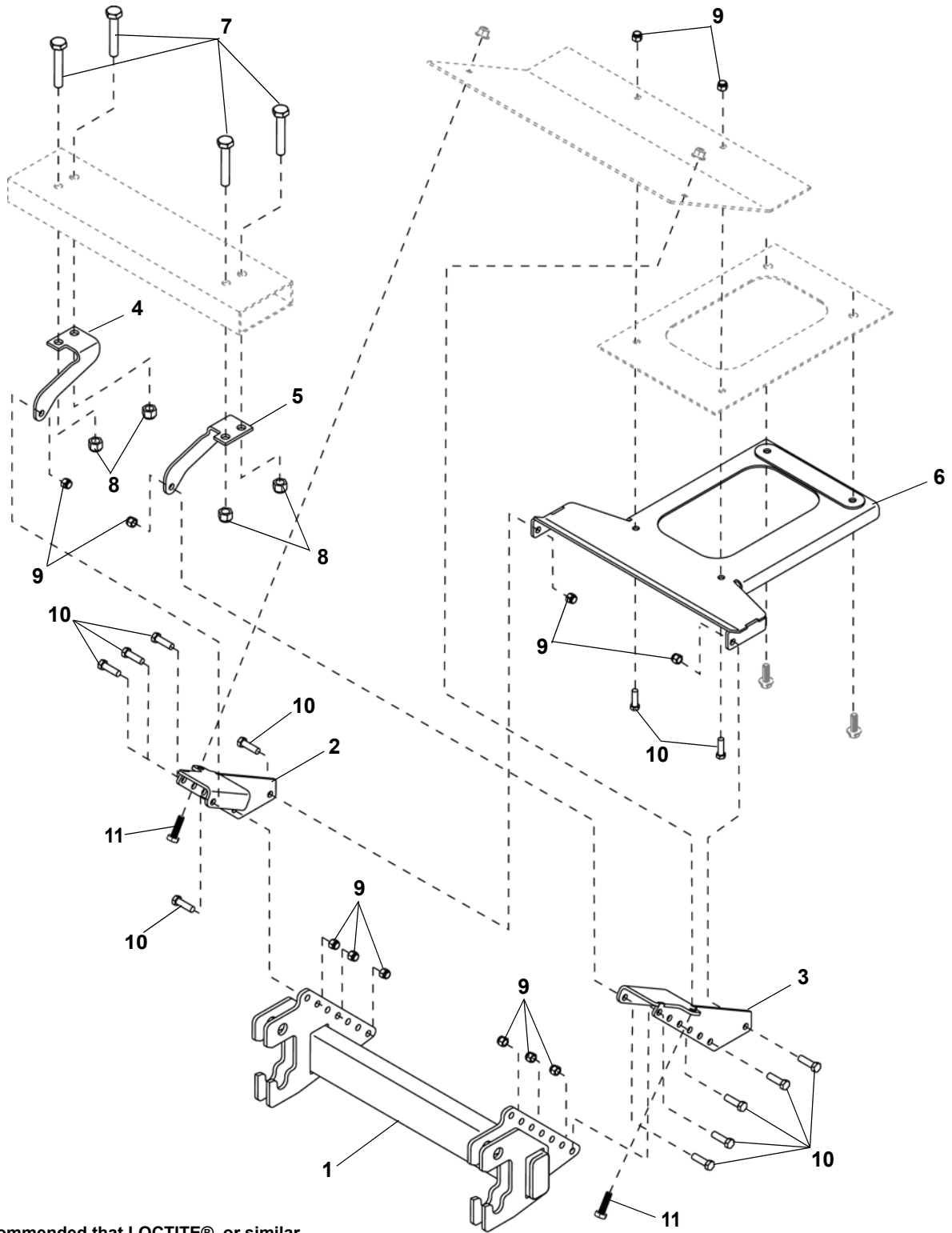

Note: It is recommended that LOCTITE®, or similar thread locking product, be used on ALL mounting hardware (i.e. Nuts, Cap Screws, Bolts, etc.).

PARTS LIST

ITEM	PART NO.	DESCRIPTION	QTY.
1	96114780	Vehicle Center Member, UTV (Not Included).....	1
2		Bracket, Front, PS.....	1
3		Bracket, Front, DS	1
4		Bracket, Top, PS	1
5		Bracket, Top, DS.....	1
6		Bracket, Bottom	1
7		HHCS, 1/2"-13 x 3"	4
8		LN, 1/2"-13.....	4
9		LN, 3/8"-16.....	12
10		HHCS, 3/8"-16 x 1-1/4"	12
11		HHCS, M10-1.5 x 30 mm.....	2
12	96115041	Kit, HDWE (Not Shown) (Includes Items 7-11)	1

NOTES

NOTES

SNO-WAY® INTERNATIONAL, INC.



Hartford, WI 53027 USA
Website: www.snoway.com
©2024 Sno-Way® International