

SNO-WAY®

SNOW & ICE CONTROL EQUIPMENT

INSTALLATION & OWNER'S MANUAL

**V-BOX SPREADER
POLY DUAL ELECTRIC
MODEL PDE500 - 1/2 CUBIC YARD
MODEL PDE600 - 3/4 CUBIC YARD
MODEL PDE800 - 2 CUBIC YARD**

SPREADERS WITH SERIAL NUMBERS AFTER:
5PDE100500, 6PDE100500, 8PDE100500

CHUTES WITH SERIAL NUMBERS AFTER:
PDELC100000, PDESC100000

TABLE OF CONTENTS

	Page
INTRODUCTION	2
SAFETY	3
GENERAL INFORMATION	4
SPREADING OPERATION	5
Spreading Mediums.....	5
INSTALLATION.....	6
Inverted-V Set-Up.....	6
Inverted-V Installation	7
Mounting the Spreader Onto the Vehicle.....	8
Spreader Centering System.....	9
Attach Chute.....	10
Spreader Control and Wiring Installation.....	10
THEORY OF OPERATION.....	11
Auger Drive System.....	11
Spinner Drive System.....	11
Shield Adjustment	11
Auger Jam Release.....	12
Auger Relief Tool (Optional)	12
MAINTENANCE	13
Metri-Pack™ Connector Repair	13
WIRING SCHEMATIC - DUAL VARIABLE CONTROL	15
WIRING SCHEMATIC - PDE SPREADER CONTROL.....	16
TORQUE SPECIFICATIONS.....	17
DEALER CHECKLISTS.....	BACK COVER

INTRODUCTION

This manual was written for the assembly, installation and maintenance of your new Sno-Way® POLY DUAL ELECTRIC V-BOX SPREADER (PDE). Most importantly, this manual provides an operating plan for safe use. Refer to the Table of Contents for an outline of this manual.

Please keep this manual with your machine at all times as reference material and so it can be passed on to the next owner if the machine is sold.

We require that you read and understand the contents of this manual COMPLETELY, especially the chapter on SAFETY, before attempting any procedure contained in this manual.



The Society of Automotive Engineers has adopted this SAFETY ALERT SYMBOL to pinpoint characteristics that, if NOT carefully followed, can create a safety hazard. When you see this symbol in this manual or on the machine itself, BE ALERT!, your personal safety and the safety of others, is involved.

• Defined in the next column, are the SAFETY ALERT messages and how they will appear in this manual.

	WARNING
Information, that if not carefully followed, can cause personal injury or death!	

	CAUTION
Information, that if not carefully followed, can cause injury or damage to equipment!	

NOTE: Additional information concerning the equipment or the procedure that may or may not be contained elsewhere in this manual.

BE AWARE! It is illegal to remove, deface or otherwise alter the safety decals mounted on this equipment.

Record the Spreader Serial Number and Spreader Model Number in the space provided below as a handy record for quick reference. The Serial Number decal is located on the drivers side frame support farthest from the discharge end. This decal contains information that your Dealer needs to answer questions, order replacement parts or to complete warranty work, if needed, for your unit.

We reserve the right to make changes or improve the design or construction of any part(s) without incurring the obligation to install such parts or make any changes on any unit previously delivered.

NAME PLATE DATA	
SPREADER MODEL NUMBER	_____
SPREADER SERIAL NUMBER _____ PDE _____ <small>(Located on Front Support Bracket - DS)</small>	
CHUTE SERIAL NUMBER:	
PDESC (SHORT CHUTE)	_____
PDELC (LONG CHUTE)	_____
(FILL IN)	

DEALER	
NAME	_____
ADDRESS	_____
CITY _____ STATE _____ ZIP _____	
PHONE () - _____	
(FILL IN)	

ORIGINAL PURCHASER	
NAME	_____
ADDRESS	_____
CITY _____ STATE _____ ZIP _____	
PHONE () - _____	
(FILL IN)	

Graphics and illustrations may be used which may show equipment and/or options not included in every installation without incurring the obligation to install such parts or make changes on units previously delivered.

Sno-Way Service Parts Manuals are available on-line or at your authorized Sno-Way dealer. Request part number 97101880 & 97101915 for the PDE series spreaders.

Factory contact information is available at www.snoway.com.

SAFETY

BEFORE ATTEMPTING ANY PROCEDURE IN THIS BOOK, READ AND UNDERSTAND ALL THE SAFETY INFORMATION CONTAINED IN THIS SECTION. IN ADDITION, ENSURE ALL INDIVIDUALS WORKING WITH YOU ARE ALSO FAMILIAR WITH THESE SAFETY PRECAUTIONS.

For your safety Warning and Information Decals have been placed on this product to remind the operator to take safety precautions. It is important that these decals are in place and are legible before operation begins. New decals can be obtained from Sno-Way or your local dealer.

REMEMBER The careful operator is the best operator. Most accidents are caused by human error. Certain precautions must be observed to prevent the possibility of injury to operator or bystanders and/or damage to equipment.

FIRST TIME OPERATION When running for the first time or after the unit has not been used for a long period of time, run and inspect the auger system without spinner and chute assembly attached.

NEVER operate spreader when under the influence of alcohol, drugs or other medications that could hamper your judgement and reactions. An accident may result in serious injury or death to other persons or yourself.

ALWAYS operate vehicle in a well-ventilated area. The carbon monoxide in exhaust gas is highly toxic and can cause injury or death.

NEVER wear wrist watches, rings or other jewelry when working on the vehicle or individual equipment. These things can catch on moving parts or cause an electrical short circuit that could result in personal injury.

ALWAYS wear safety goggles when working on the vehicle to protect your eyes from battery acid, gasoline, and dust or dirt from flying off of moving engine parts.

ALWAYS wear safety glasses with side shields when striking metal against metal! In addition, it is recommended that a softer (non-chipable) metal material be used to cushion the blow. Failure to heed could result in injury to the eye(s) or other parts of the body.

NEVER allow children or unauthorized person to operate this spreader.

NEVER exceed 45 m.p.h. when loaded spreader is attached to vehicle. Braking distances may be increased and handling characteristics may be impaired at speeds above 45 m.p.h.

ALWAYS lock the vehicle when unattended to prevent unauthorized operation.

ALWAYS check the job site for terrain hazards, obstructions and people.

ALWAYS check surrounding area for hazardous obstacles before operating this unit.

ALWAYS make sure personnel are clear of area being spread. Material is discharged from spreader at a high rate of speed and could injure bystanders.

NEVER leave materials in hopper for long periods of time. Remember salt is hygroscopic and will attract enough atmospheric moisture to cause it to “cake”.

NEVER work on the vehicle without having a fully serviced fire extinguisher available. A 5 lb or larger CO² or dry chemical unit specified for gasoline, chemical or electrical fires, is recommended.

ALWAYS make sure that all safety guards are in place before operating the spreader.

ALWAYS shut off the vehicle, unplug spreader, place the vehicle transmission in “Park”, turn the vehicle and spreader ignition switches to “OFF” position and firmly apply the parking brake of the vehicle before servicing or making any adjustments to the spreader.

ALWAYS wait for all movement to stop before servicing or adjusting the spreader.

NEVER climb on or allow others to climb on the spreader.

ALWAYS reassemble any parts or hardware removed for cleaning or adjusting before operating the spreader.

ALWAYS remove any tools and other materials from the spreader before operating the spreader

ALWAYS use auxiliary warning lights, except when prohibited by law, when operating the spreader.

NEVER allow hands, hair or clothing to get near any moving part of the spreader. Never wear neckties or loose clothing when working on the spreader or the vehicle.

ALWAYS be aware of and avoid contact with hot surfaces such as engine and exhaust.

ALWAYS inspect the unit periodically for defects. Parts that are broken, missing or plainly worn must be replaced immediately. Never operate the unit when in need of maintenance.

REMEMBER it is the owner’s responsibility for communicating information on the safe use and proper maintenance of this machine.

GENERAL INFORMATION



WARNING

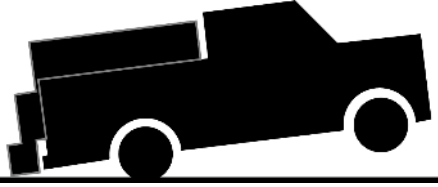

Check the vehicle's load rating certification sticker for the maximum vehicle capacity, and **DO NOT** overload beyond the vehicle GVWR or GAWR. Overloading could result in an accident, or damage to the vehicle.

FAILURE TO HEED CAN RESULT IN INJURY OR DEATH.

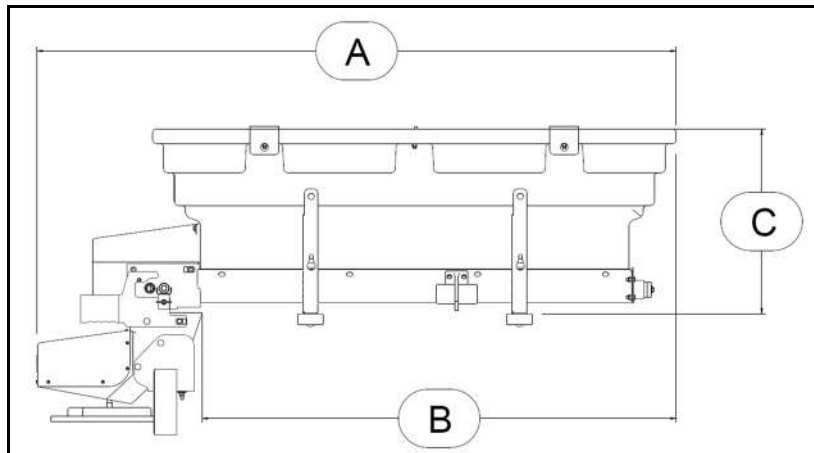



Figure 1-1

SPREADER MODEL	CAPACITY	OVERALL LENGTH (A)	BODY SIDE LENGTH (B)	OVERALL HEIGHT (C)	WIDTH	AUGER DIAMETER	EMPTY WEIGHT (No Chute or Screen)	RECOMMENDED USE
PDE500	0.5 cu. yd. (0.38 m ³)	75.8 in. (1926 mm)	53.2 in. (1350 mm)	25 in. (635 mm)	39 in. (991 mm)	3 in. (76.2 mm)	215 lb (97.5 kg)	1/2 Ton And Full HD Trucks
PDE600	0.75 cu. yd. (0.57 m ³)	87.9 in. (2232 mm)	65.2 in. (1656 mm)	25 in. (635 mm)	39 in. (991 mm)	3 in. (76.2 mm)	244 lb (110.8 kg)	1/2 Ton And Full HD Trucks
PDE800	2 cu. yd. (1.53 m ³)	105 in. (2667 mm)	82 in. (2083 mm)	36 in. (914.5 mm)	48 in. (1219 mm)	3 in. (76.2 mm)	360 lb (163.3 kg)	1/2 Ton And Full HD Trucks

IMPORTANT



Proper spreader operation depends on material selection and usage.

- Spreading material, when left in the hopper overnight, may settle or accumulate moisture, become solid and jam the spreader auger. **ALWAYS** empty the spreader when not in use.
- If improper materials are fed through the spreader or if materials are used improperly, constant circuit breaker tripping may result.

These conditions, resulting in burnt out electric motors will not be covered under warranty.

SPREADING OPERATION

Spreading Mediums

Categories of Spreading Mediums

Spreading Mediums come in three different categories:

- Free Flowing - These materials generally have a granular size of 1/8 to 1/4 inch, and have no chunks when poured out.
- Chunky Free Flowing - These materials are the same granular size as free flowing, but have chunks or bridging that can range from 1/2 inch in diameter up to 6-12 inches in diameter. These chunks can easily escape visual detection when being poured out of a bag, and give the appearance of free flowing material.
- Bridging / Non Flow - These materials chunk up when poured, or stick together and combine into clumps of break resistant material. They may pour well down the side of the hopper, but when wedged together at the bottom of the hopper, materials will be compacted, clump together and resist breakup. Vibration by vibrators tends to compact the materials even more. A physical "breaker" is required to make this material move.

Usable Spreading Mediums

There are a number of spreading mediums that are usable with your PDE Series Spreader. Some examples are:

- Free Flowing Salt, Course and Fine - Free Flowing Salt typically comes out of a bag, and is dry and free flowing.
- Treated Salt, Course and Fine - Treated Salt is usually more "sticky", and bridges easily. PDE Series Spreaders require the vibrator to be turned on for optimum flow with this material. Some treated salts may not even flow through the spreader at all. Be sure to test small batches to determine the flow characteristics of the material you have chosen.
- Calcium Chloride - Calcium Chloride can become "sticky and chunky". PDE Series Spreaders may require the vibrator to be operated for optimum flow with this material.

Operating Capacities

<i>Model</i>	<i>Hopper Capacity</i>
PDE500	0.5 cu. yd. (0.38 m³)
PDE600	0.75 cu. yd. (0.57 m³)
PDE800	2 cu. yd. (1.53 m³)

Use the following table as a guide to calculate the weight of material placed in the spreader:

IMPORTANT: Material weights given are average weights for DRY materials. Depending on moisture content of material, weights will vary. NEVER load the vehicle this Spreader is installed on beyond the vehicle manufacturers maximum Gross Vehicle Weight Rating.

Estimate - Number of Bags at 75 lbs/Cubic Foot		
Spreader	Using 40 lb Bags	Using 80 lb Bags
PDE500	18.5 Bags	9.5 Bags
PDE600	28 Bags	14 Bags
PDE800	74 Bags	37 Bags
Example: 14 Bags x 80 lbs = 1,120 lbs		

REMEMBER Calcium and Sodium Chloride (Salt) materials are hygroscopic (attract moisture) and will form a solid block when exposed to atmospheric moisture. It is easier to unload unused material and clean out the hopper in a timely manner than chip out a 200 lb hardened salt block later.

INSTALLATION

Inverted-V Set-Up

There are two different inverted-v designs, each with different capabilities. The One Piece design is all one assembly inside the hopper and is limited to only flowing high and medium flow material like dry bag or bulk salt. The Sectional design can have sections disassembled and will flow numerous types of material depending on how it is orientated.

To set-up your inverted-V:

1. Determine which design your spreader has. (See *Figure 1-2 and Figure 1-3.*)

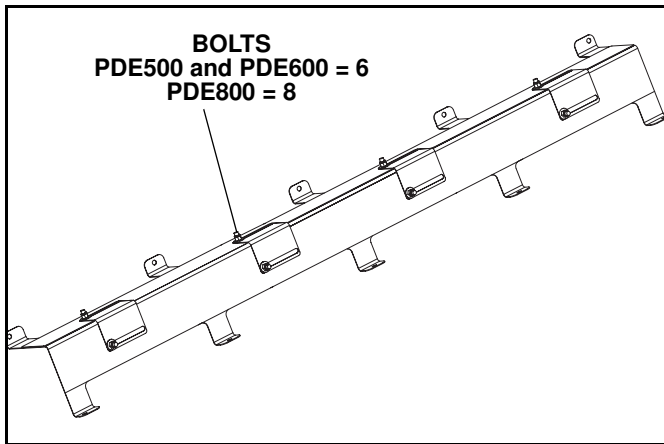

Figure 1-2 (One Piece Design)

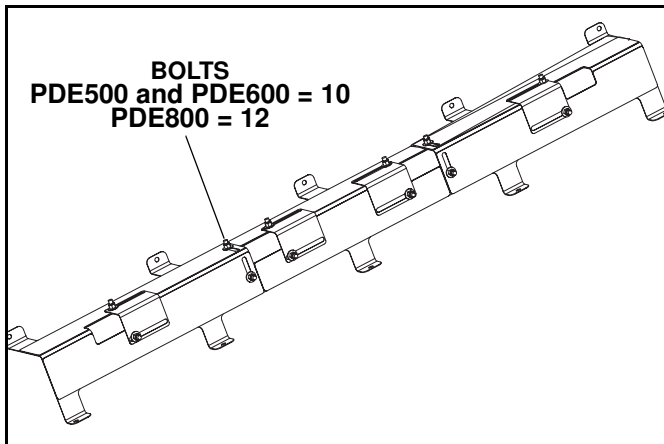

Figure 1-3 (Sectional Design)

2. Review the classifications of material and what which types of material will flow through your inverted-V:

- One Piece Design - High and Medium Flow
- Sectional Design - High, Medium, and Low Flow

Material Classification:

High Flow Material: Materials that do not bridge. Very dry and free flowing.

Examples:

- Dry Fine Bulk Salt
- Dry Bagged Salt
- Dry Salt with Calcium Chloride Flakes
- Pea Gravel

Medium Flow Material: Materials that may bridge. Not completely dry and will clump a little in your hand if you try to form it into a ball.

Examples:

- Dry Coarse Bulk Salt
- Damp Coarse Bulk Salt
- Very Coarse Bulk Salt

Low Flow Material: Materials that will bridge. Damp, coarse or fine, material that will clump and form a ball in your hands.

Examples:

- Sand / Salt Mix
- Sand
- Damp Coarse Bulk Salt
- Damp Fine Bulk Salt
- Magic Salt
- Cinders

3. Temporarily remove the screen off the spreader, then set-up the inverted-v based on the classification of material that will be used and design of inverted-v you have.

High Flow Material

A. One Piece Design - Top baffles closed and side baffles fully raised. If more restricted flow is desired, the side baffles can be lowered (See *Figure 1-4.*)

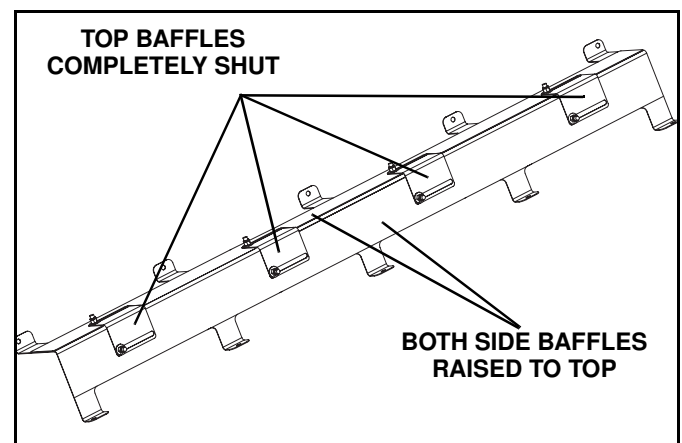

Figure 1-4

B. Sectional Design - Top baffles closed and side baffles fully raised except for the section closest to the discharge end. The section nearest the chute should be rotated to prevent excess material from flowing out of the spreader during transport. If more restricted flow is desired, the remaining side baffles can be lowered (See Figure 1-5).

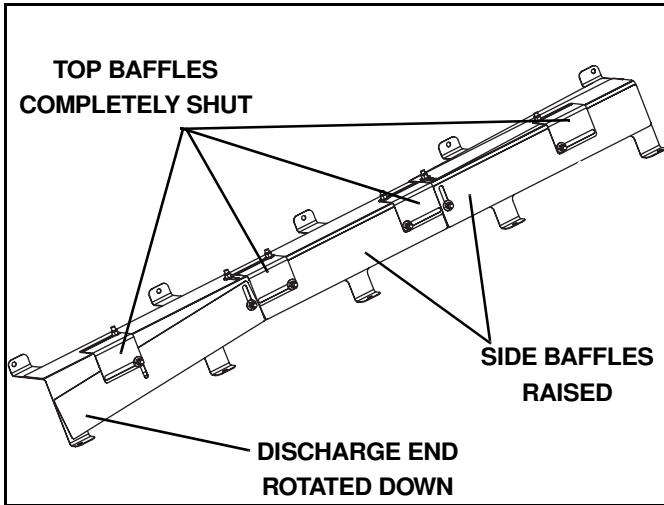

Figure 1-5

Medium Flow Material

A. One Piece Design - Top baffles open and side baffles fully raised. The top baffles can be partially or fully open depending on desired flow to the auger. Note: If using a PDE800, an additional vibrator (99101247) is recommended (See Figure 1-6).

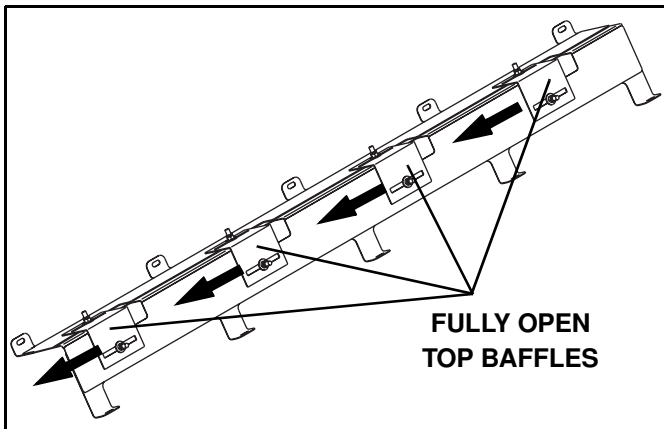

Figure 1-6

B. Sectional Design - Top baffles open and side baffles fully raised (See Figure 1-7). The top baffles can be partially or fully open depending on desired flow to the auger. Note: If using a PDE800, an additional vibrator (99101247) is recommended.

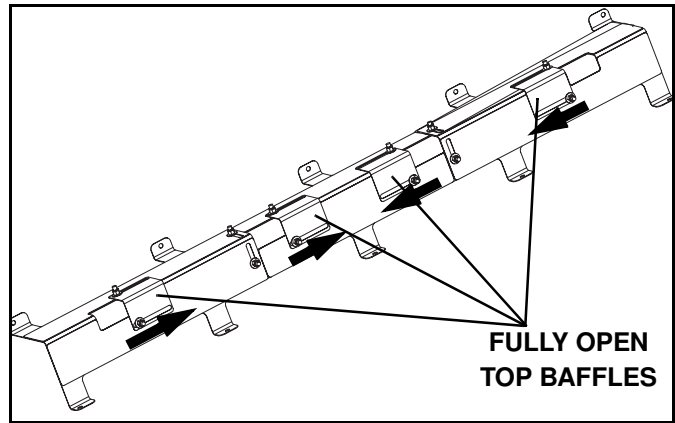

Figure 1-7

Low Flow Material

- A. One Piece Design - Does not work for low flow material.
- B. Sectional Design - Set up varies depending on the series of spreader you have.

PDE800

Remove the four bolts holding the center section of the inverted-v to the end sections. Then, temporarily remove the two bolts holding the center section to the hopper. Open the top baffles of the center section. Entirely remove the center section and re-install the bolts that were in the hopper. Keep the center section in case the type of material being spread changes. The remaining sections of the inverted-v should have the top baffles completely open and side baffles fully raised (See Figure 1-8).

NOTE: An additional vibrator (99101247) is needed to flow this type of material.

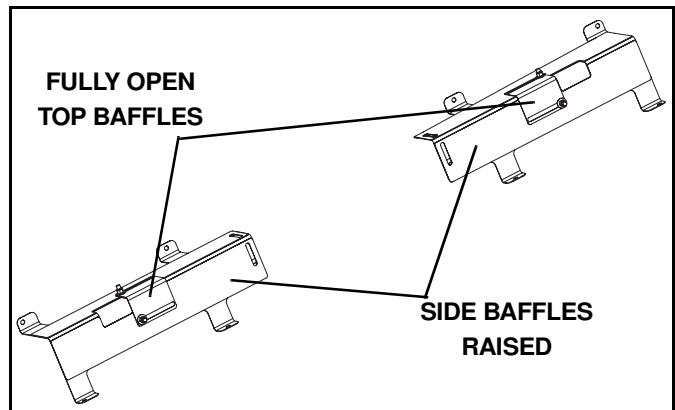

Figure 1-8

PDE600

Remove the four bolts holding the center section of the inverted-v to the end sections. Then, temporarily remove the four bolts holding the end sections to the hopper. Entirely remove the end sections and re-install the bolts that were in the hopper. Keep the end sections in case the type of material being spread changes. The remaining section of the inverted-v should have the top baffles completely open and side baffles fully raised (See Figure 1-9).

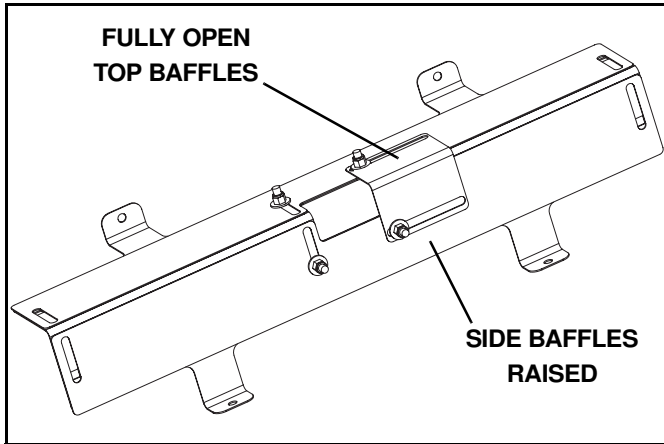

Figure 1-9

PDE500

Remove the four bolts holding the center section of the inverted-v to the end sections. Entirely remove the center section. Keep the center section in case the type of material being spread changes. The remaining sections of the inverted-v should have the top baffles completely open and side baffles fully raised (See Figure 1-10).

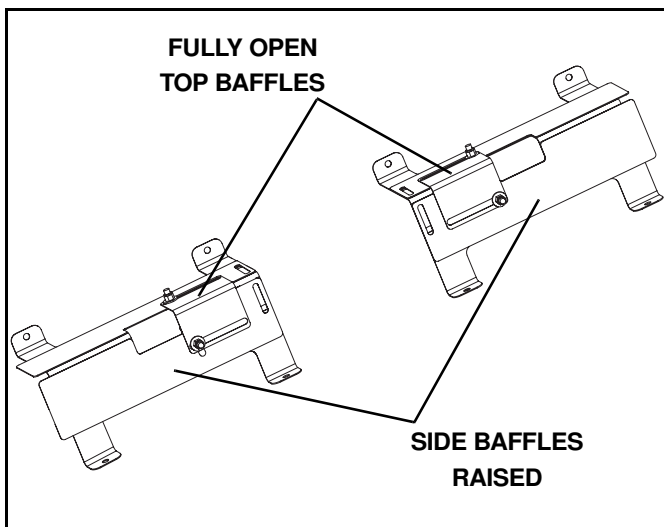
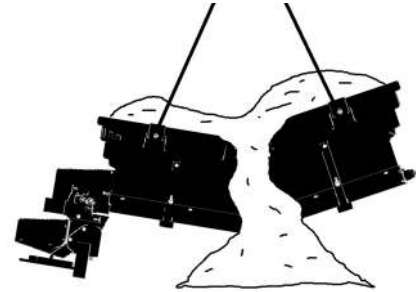

Figure 1-10

Mounting the Spreader Onto the Vehicle



WARNING



Before lifting, check that the hopper is empty of material. The lifting device must be capable of supporting the spreader's weight. See charts for spreader weights.

FAILURE TO HEED CAN RESULT IN INJURY OR DEATH.

1. Attach two lift straps through the top grate to the front and rear spreader cross supports (See Figure 1-11).

IMPORTANT: DO NOT attach the lift straps directly to the top grate. Pass the lift straps through the grate and attach them directly to the front and rear cross supports.

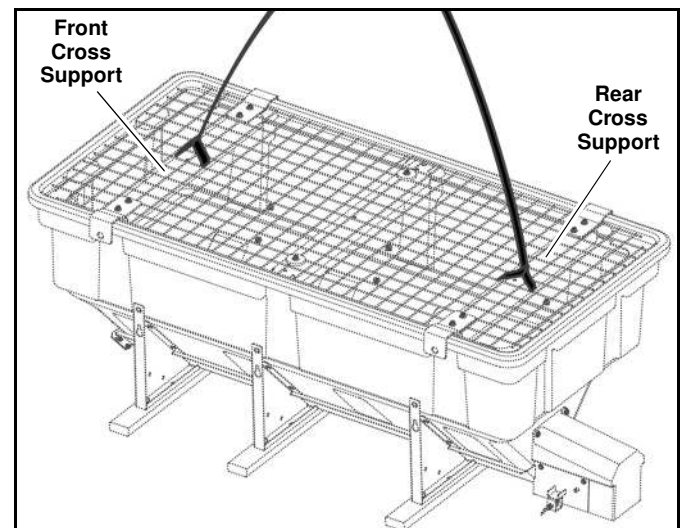

Figure 1-11

2. Remove the tailgate from the truck.

3. Attach the free ends of the lift straps to a suitable lifting device and lift the spreader slowly. Maintain the spreader horizontal position as it is lifted. (See Figure 1-12)



Figure 1-12

4. Center the spreader on the vehicle with the rear auger motor housing clear of all vehicle rear obstructions (e.g., bumper, trailer hitch, etc.) (See Figure 1-13).

NOTE: See the next section (Spreader Centering) for end user options on maintaining spreader centering on the vehicle.



Figure 1-13

5. Using suitable tie-down straps or chain, secure the spreader to the vehicle's factory installed anchor points using two tie-down brackets on each side of the spreader hopper. (See Figure 1-14)

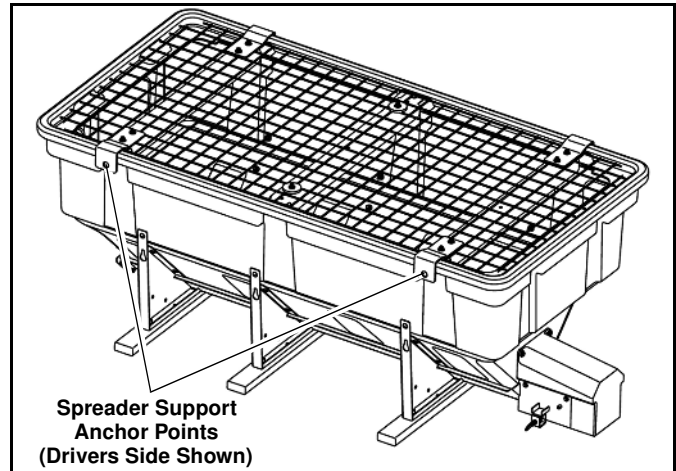

Figure 1-14

IMPORTANT: Check the tie-down devices every time the spreader is placed on the truck and loaded with material to make sure they are secure.

Spreader Centering System

All spreader models are designed to accommodate a unique spreader centering system. The spreader centering system maintains the spreader position in the center of the truck bed or dump body. It prevents the spreader from moving side to side.

The spreader centering system consists of boards mounted on the corner support brackets. Each support bracket is equipped with three holes in each side that can mate up to the centering boards.

The boards can be 2x4, 2 x 6, 2x8 or a larger piece of standard lumber. These boards are supplied by the end user along with the 1/2 in. hardware to mount them. (See Figure 1-15).

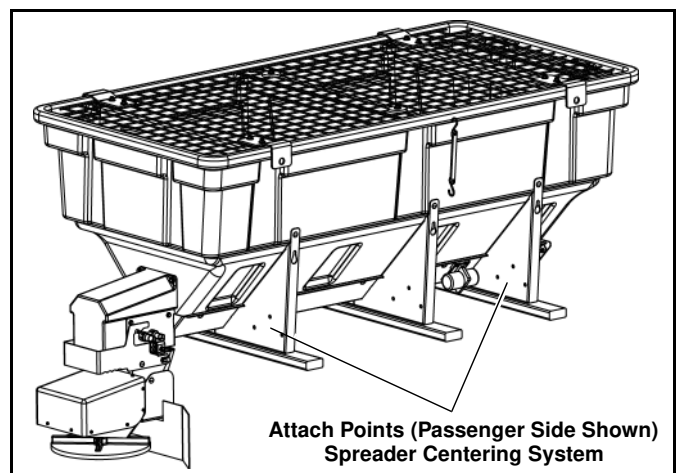

Figure 1-15

The centering boards length typically ranges from 24 to 36 inches, depending on the width of the truck bed. A centering board on each of four corners is recommended. (See Figure 1-16).

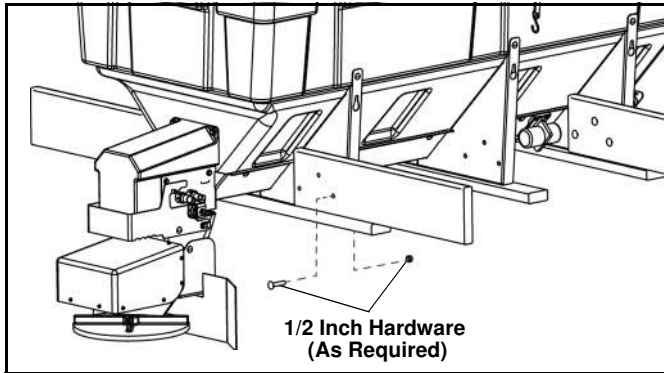

Figure 1-16

The boards keep the spreader centered in the truck body and also provide additional side support complementing the strap mountings.

Attach Chute

Pull out each auger motor housing latch pin and rotate counter-clockwise to engage detent.

1. Position the chute spinner assembly on the auger housing support pins and push the bottom of the unit forward (See Figure 1-17).

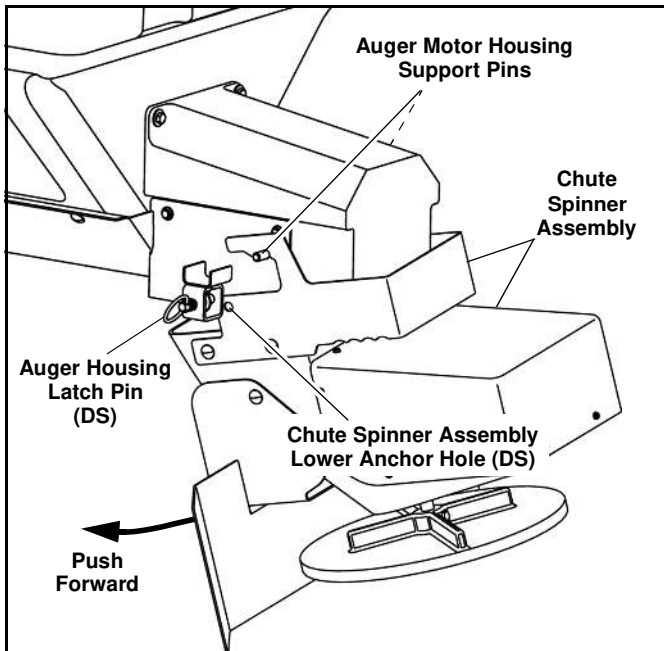

Figure 1-17

2. As the lower anchor holes align with the auger motor housing pins, pull each pin out and rotate clockwise to disengage the detent. Rotate each pin slightly as it engages the lower anchor holes on the chute spinner assembly. (See Figure 1-18).

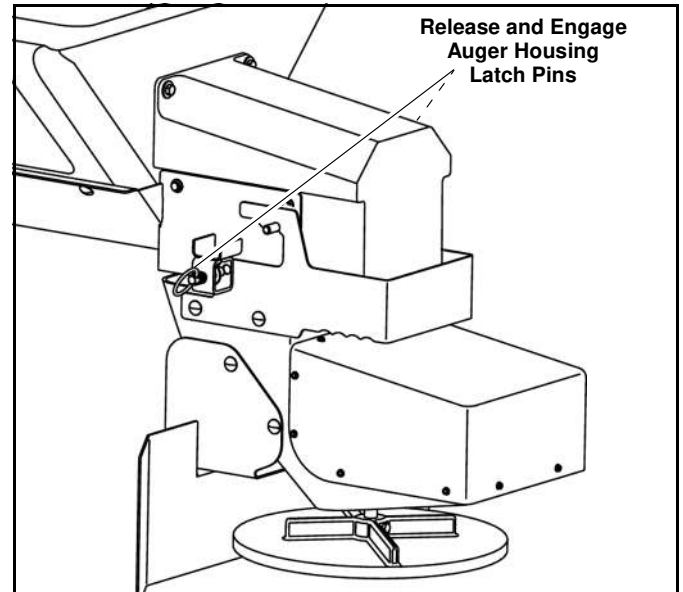

Figure 1-18

3. Plug the spinner wiring harness into the spreader harness on the right side of the auger motor housing.

Spreader Control and Wiring Installation

Follow the instructions supplied with the controller package.

THEORY OF OPERATION

Auger Drive System

The Auger is driven by a 12V DC Gear Motor. Using the control, the auger's RPM can be increased or decreased. When the RPM is decreased, less material will be delivered to the spinner. When the RPM is increased, more material will be delivered to the spinner. The amount to material that can be delivered to the spinner is limited by how much material can pass by the inverted v and down into the trough of the spreader.

Spinner Drive System

The Spinner is driven by a 12V DC Gear Motor. Using the control, the spinner's RPM can be increased or decreased. When the RPM is decreased, the distance the material can spread will decrease. When the RPM is increased, the distance the material can spread will increase.

Shield Adjustment

The flow pattern of the material is dependent on material type and density. The spreader is designed for free flowing materials that should spread evenly in an arc pattern behind the vehicle.

Bend the internal baffle in the chute housing "Up" or "Down" to adjust the directional flow of material (See Figure 2-1).

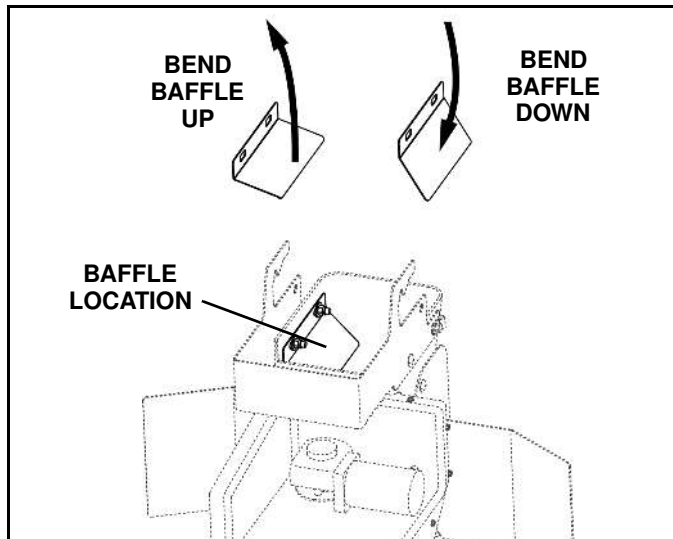

Figure 2-1

• To adjust the flow of the material to the passenger side (PS) of the vehicle, manually bend the internal baffle on the chute assembly in the "UP" position (See Figure 2-2).

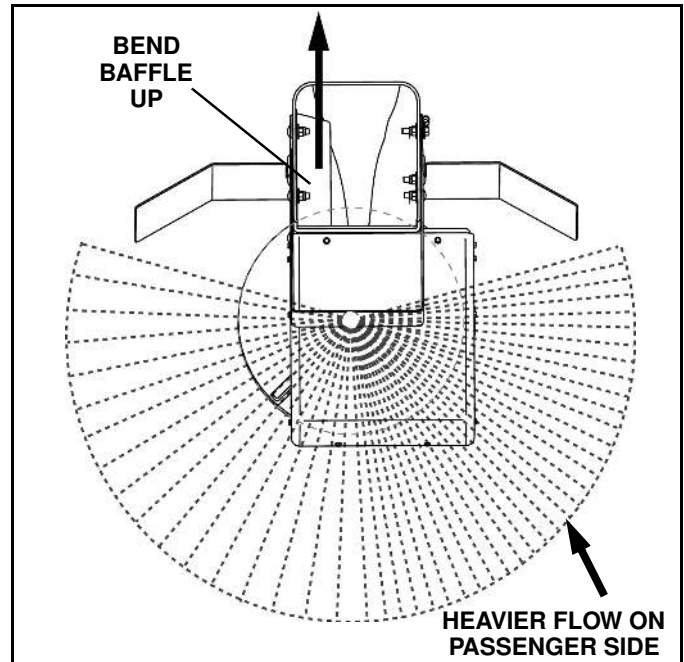

Figure 2-2

• To adjust the flow of the material to the drivers side (DS) of the vehicle, manually bend the internal baffle in the "DOWN" position (See Figure 2-3).

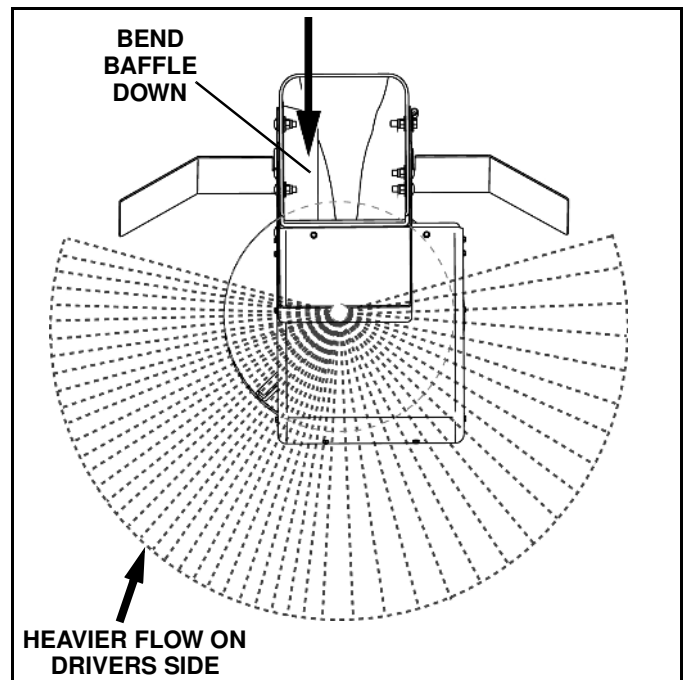

Figure 2-3

Auger Jam Release

In the case of auger jam the auger must be freed of material impaction as follows:

- Disconnect the vehicle harness from the spreader.
- Remove the Spinner Chute Assembly.
- Disconnect the Hopper Restraints.
- Remove the Hopper Screen.
- Dig out the hopper down to the Inverted-V.

NOTE: The relief tool cross bolt and nut can remain installed in the auger shaft, but the relief tool should be removed from the shaft after use, and stored for reuse if required.

- Once any auger jam is relieved, proceed to reassemble the screen and support brackets.
- Install Hopper Restraints.
- Put Spinner Assembly back onto the spreader.
- Reconnect Harness.
- Resume Spreading materials.

**WARNING**

Disconnect the vehicle harness from the spreader before the installation and use of the auger relief tool.

FAILURE TO HEED CAN RESULT IN INJURY OR DEATH.

Auger Relief Tool (Optional)

NOTE: The Auger Relief Tool is an optional accessory that is designed to free up a jammed auger .

Install the 96115106 relief tool cross bolt in the auger shaft at the front of the spreader, and secure with the provided locknut.

Insert the relief tool into the auger shaft and engage it into the cross bolt (See Figure 2-4).

Using the relief tool with a 3/4" socket or hand wrench, manually turn the auger counter-clockwise (CCW). The auger should spin freely with the tool.

**WARNING**

Do not try to move a hopper full or even partially full of material. The unit is not designed to be picked up or moved with material in it. Injury or even death could occur with such a maneuver. The hopper must be emptied prior to moving the unit.

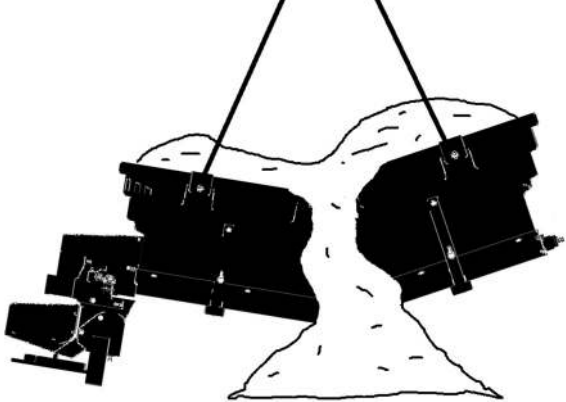

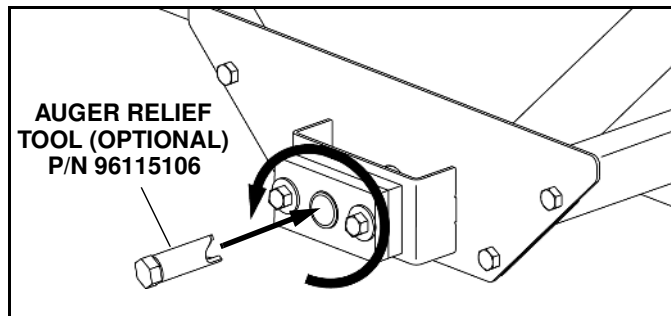

Figure 2-4

MAINTENANCE

General

- Use Quaker State NYK-77 dielectric grease, PN3329 or an equivalent grease, on all electrical connections at the beginning and end of each season, and as required during the season.

The auger main bearing is maintenance free, but does require periodic inspection. Be sure to check to see if the auger when running is rubbing on the bottom of the auger trough.

- Inspect auger for erratic rotation which may indicate that the auger is bent.
- Check the vibrator operation.
- Inspect the electrical connections and be sure to apply dielectric grease to them to prevent corrosion during both operation and storage.
- Empty the spreader when it is not in use to prevent the auger from becoming frozen.
- Wash out the spreader when it is not in use.

Metri-Pack™ Connector Repair

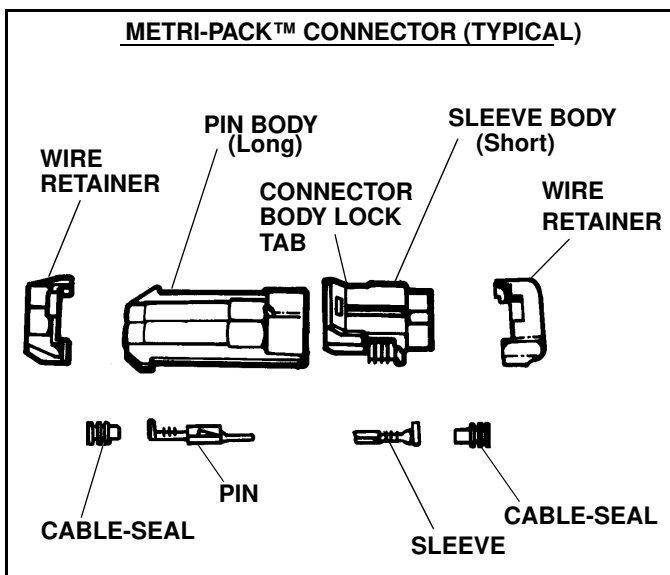

Figure 3-1

IMPORTANT: Identify wire number/color locations with connector terminal letters before disassembly.

Terminal Removal

1. Lift connector body lock tab and pull to separate connector halves.
2. Remove wire retainer on sleeve body or pin body, as necessary, with a screwdriver and save for re-use (See Figure 3-2).

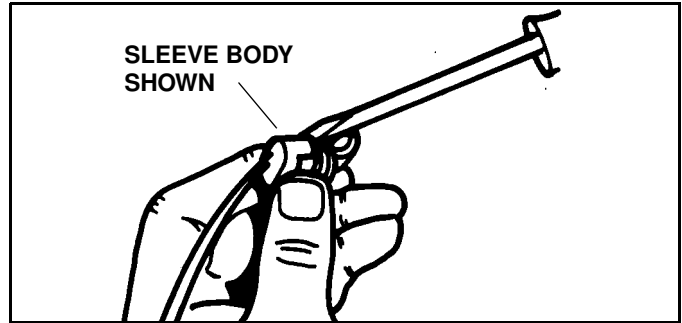

Figure 3-2

3. Push wire into connector as far as possible to release pressure on terminal locking tang.

4. Locate the terminal lock tang in the connector cavity by looking into the connector from the mating end. Use Terminal Removal Tool (#96102499) to depress the lock tang and gently pull wire to remove wire and terminal from connector body. (See Figure 3-3).

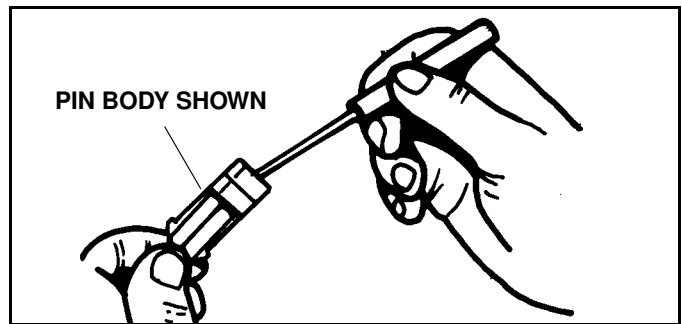

Figure 3-3

Terminal Replacement

1. Cut wire as close as possible to old terminal and remove old cable seal. (See Figure 3-4).

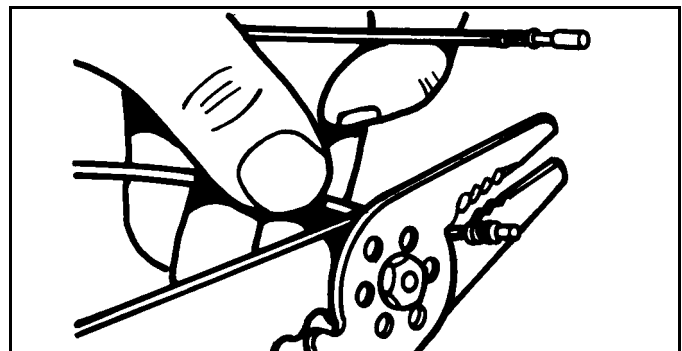

Figure 3-4

IMPORTANT: METRI PACK™ connectors are keyed A, B, C, etc. for proper contact mating. Be sure contacts and wire colors/numbers match and are in proper alignment.

2. Install new correct size cable seal on wire.

Cable seals are available for three sizes of wire:

- Large - 1.0 mm (16 gauge) wire
- Medium - 0.8 mm (18 gauge) wire
- Small - 0.5 mm (20 gauge) wire

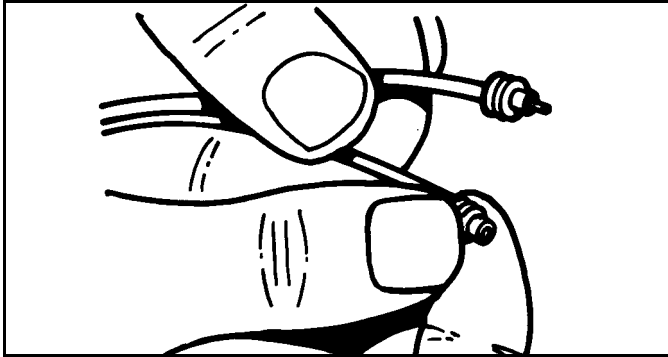

Figure 3-5

3. Strip insulation from wire to expose 6mm (1/4 in) and align cable seal with edge of insulation.

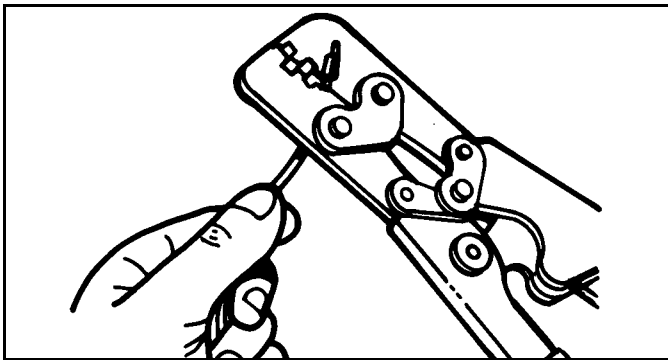

Figure 3-6

4. Place appropriate terminal on wire and use Crimper (#96102500) to secure contact in place with a "W" type crimp.

5. Use Crimper to secure cable seal to terminal.

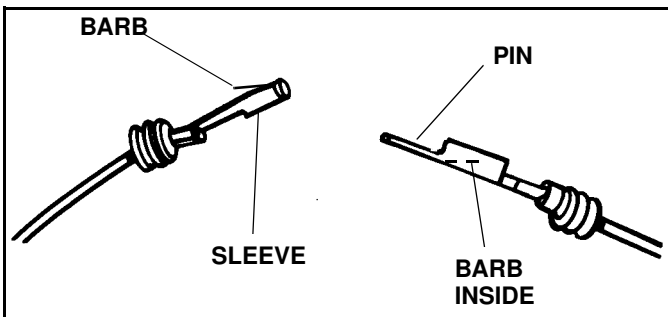

Figure 3-7

IMPORTANT: Proper barb location and orientation for installation of sleeve and pin is shown.

NOTE: Connector bodies are keyed for proper terminal mating. Be sure terminals are in proper alignment.

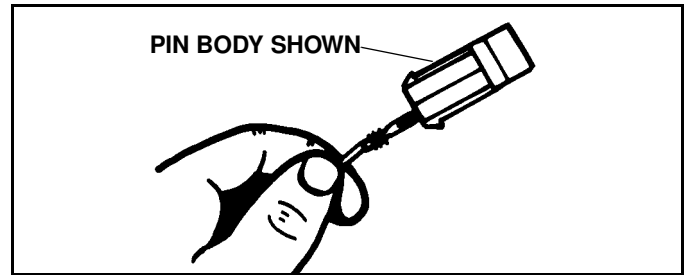

Figure 3-8

6. Push new terminal into connector body until fully seated.

7. Pull on wire slightly to be certain terminal is locked in place.

8. Install wire retainer.

9. Repeat as necessary to replace other terminals.

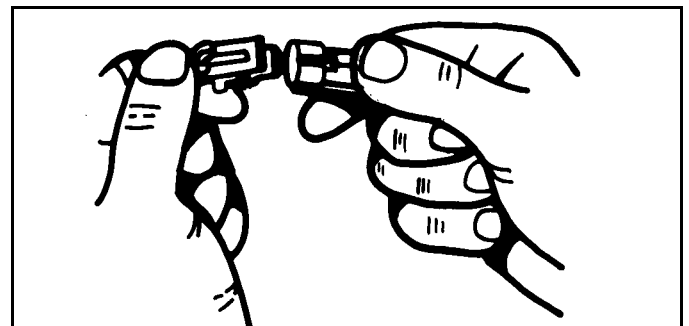
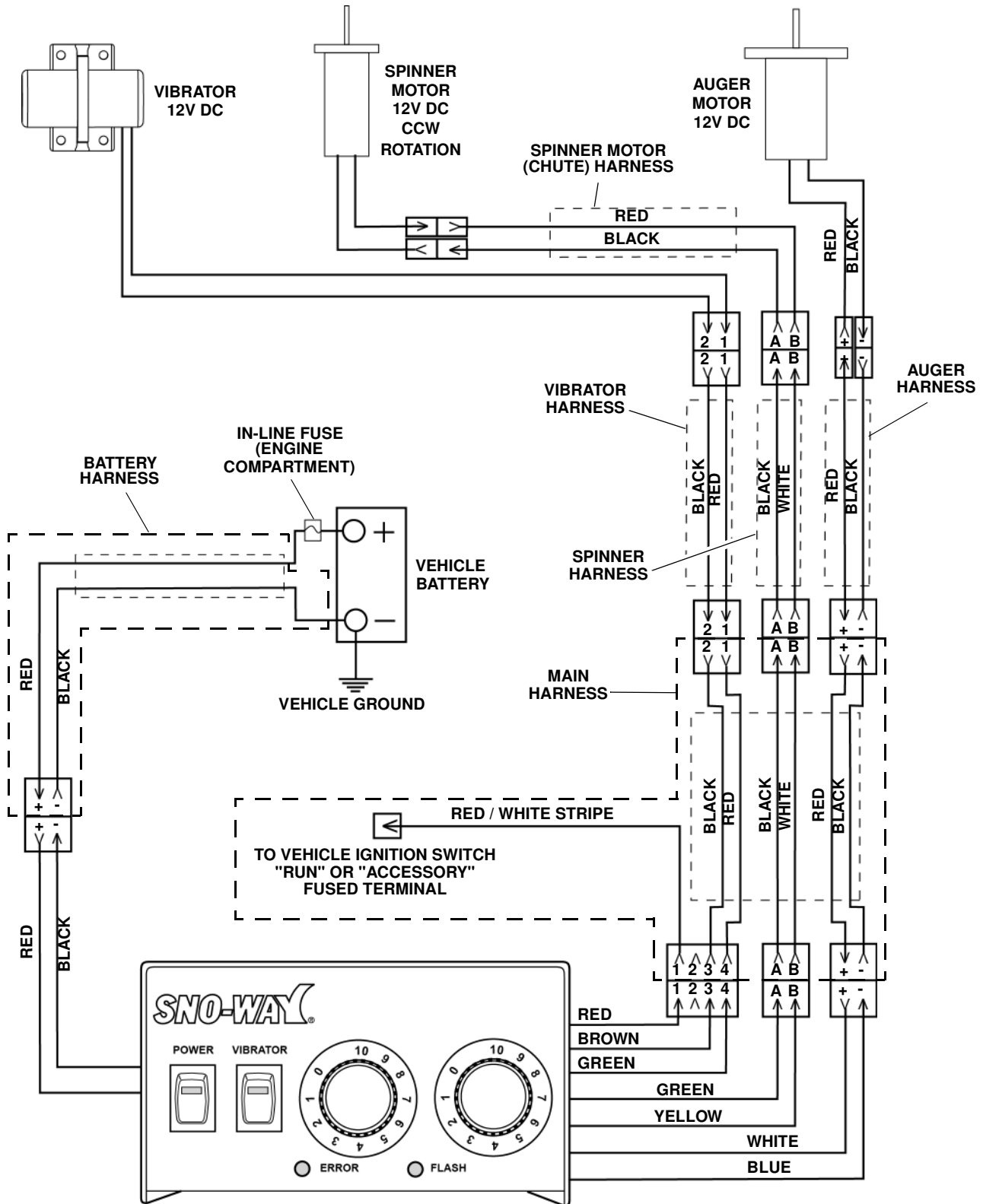

Figure 3-9

10. Close connector body.





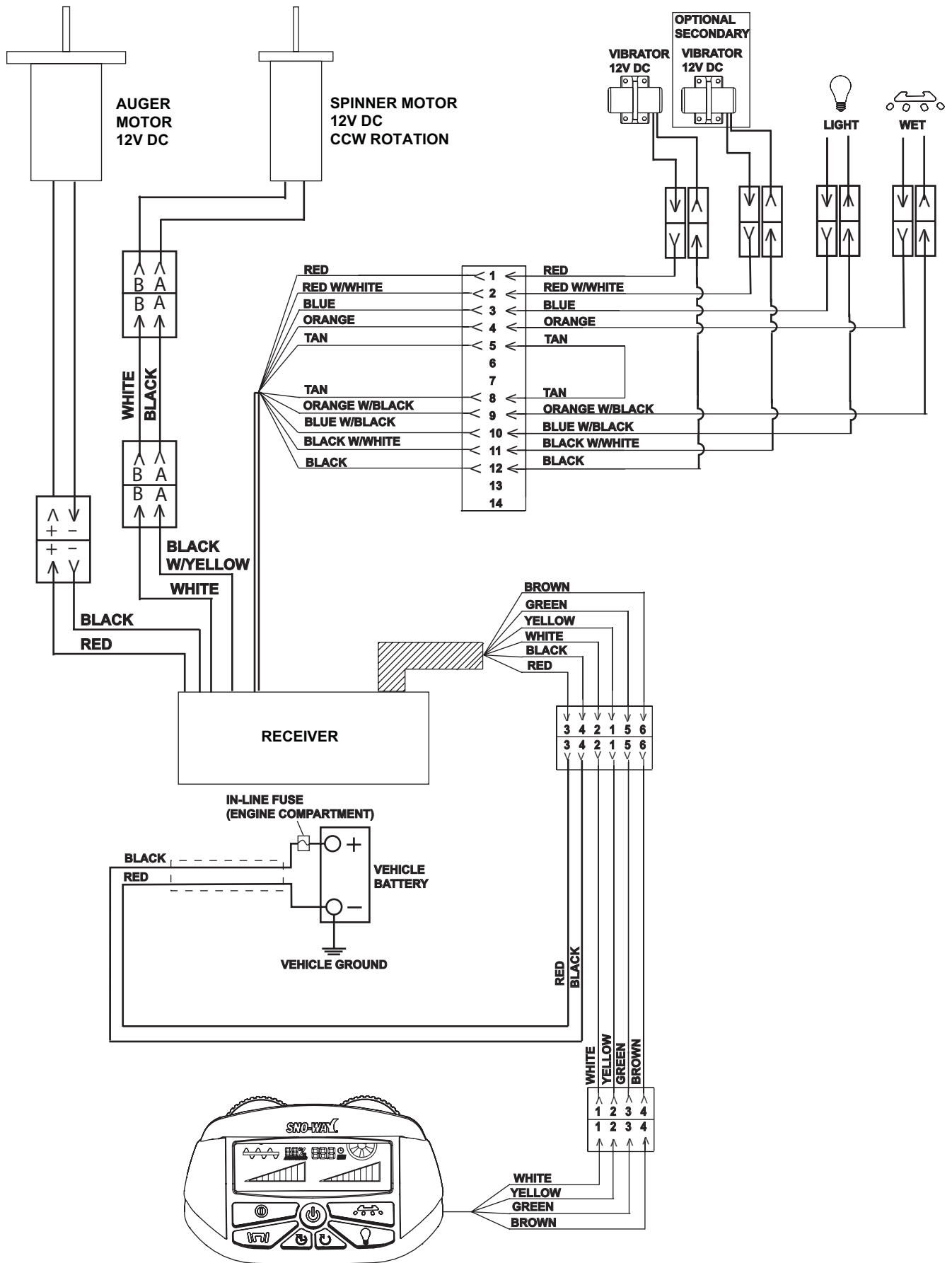

WIRING SCHEMATIC - DUAL VARIABLE CONTROL



WIRING SCHEMATIC - PDE SPREADER CONTROL



TORQUE SPECIFICATIONS

SAE Grade and Head Markings	1 or 2 No Marks 	5 5.1 5.2 	8 8.2 
	2 No Marks 	5 	8 

	Grade 1		Grade 2		Grade 5, 5.1 or 5.2		Grade 8 or 8.2	
	Lubricated ^a	Dry ^b	Lubricated ^a	Dry ^b	Lubricated ^a	Dry ^b	Lubricated ^a	Dry ^b
SIZE	lb-ft	lb-ft	lb-ft	lb-ft	lb-ft	lb-ft	lb-ft	lb-ft
10-24			21*	27*	32*	43*	45*	60*
1/4	2.8	3.5	4.5	5.5	7	9	10	12.5
5/16	5.5	7	9	11	15	18	21	26
3/8	10	13	16	20	26	33	36	46
7/16	16	20	26	32	41	52	58	75
1/2	25	31	39	50	63	80	90	115
9/16	36	45	56	70	90	115	130	160
5/8	50	62	78	100	125	160	160	225
Metric Grade 8.8								
SIZE	lb-ft			SIZE	lb-ft			
M6	7			M12	60			
M8	17			M14	95			

DO NOT use these values if a different torque value or tightening procedure is given for a specific application.

Fasteners should be replaced with the same or higher grade. If higher grade fasteners are used, these should only be tightened to the strength of the original.

^a "Lubricated" means coated with a lubricant such as engine oil, or fasteners with phosphate and oil coatings.

^b "Dry" means plain or zinc plated without any lubrication

* Values with asterisk are in lb-in.

SNO-WAY® INTERNATIONAL, INC.

SNO-WAY
SNOW & ICE CONTROL EQUIPMENT

Hartford, WI 53027 USA
Website: www.snoway.com
©2016 Sno-Way® International

DEALER PRE-DELIVERY CHECKLIST

The following inspections **MUST** be accomplished prior to delivering the SNO-WAY® PDE SERIES V-BOX DUAL ELECTRIC SPREADER to the customer.

Place an X ☒ in the box after accomplishing each item on this checklist.

CHECK THAT:

- Parts have not been damaged in shipment. Repair or replace items that are loose, dented or missing.
- All covers, guards and decals are in place and attached securely.
- Controller and electrical wiring is properly installed.
- Inverted V is installed properly and all hardware is secure.
- Chute has been installed, harness connected and secured.
- Electric auger, spinner and vibrator motors are operating properly.

Start the vehicle engine and place an X ☒ in the box after accomplishing each item.

CHECK THAT:

- Auger and spinner shafts rotate freely.
- Auger drive rotation is correct (auger rotation as viewed from bearing end is CCW).
- Spinner rotation is correct (spinner rotation as viewed from top of hopper is CCW).
- Speed can be adjusted through speed range with controller.
- Listen for abnormal noises or vibrations; Repair or replace as necessary.

DELIVERY CHECKLIST

The following checklist is to be accomplished with the customer present, place an X ☒ in the box after accomplishing each item.

- After giving the customer his operating manual, instruct him to read it **PRIOR** to operating the spreader. If he has any questions or does not understand part(s) of the manual, ask him to contact the dealer for answers or explanations **BEFORE** operating the unit.
- Record the spreader and chute serial numbers, date of purchase, purchaser's name and address, and the dealers name, address and phone number in the space provided on page 1 of the owner's manual.
- Explain spreader installation and removal procedures.
- Demonstrate all controller functions.
- Fill out warranty Registration Card and provide the original to customer. Copy for your records. Register the warranty on-line prior to release to customer. NO warranty claims can be honored if the warranty is not registered and on file at the factory.

SNO-WAY® INTERNATIONAL, INC.

SNO-WAY
SNOW & ICE CONTROL EQUIPMENT

Hartford, WI 53027 USA
Website: www.snoway.com
©2016 Sno-Way® International