

# **SNO-WAY**®

**SNOW & ICE CONTROL EQUIPMENT**

## **ASSEMBLY & INSTALLATION INSTRUCTIONS**

**VEHICLE MOUNT KIT 99101187  
AND  
VEHICLE CENTER MEMBER 96114780**

TO FIT  
2011 - 2014 Arctic Cat Prowler  
2011 - 2015 Arctic Cat Prowler HDX  
2012 - 2017 Exmark 500/700  
2012 - 2017 Toro 500/700



©2024 Sno-Way® International

97101916C



1. THINK SAFETY, ALWAYS WEAR SAFETY GLASSES WHEN PERFORMING THE OPERATIONS PRESCRIBED IN THESE INSTRUCTIONS
2. READ ALL INSTRUCTIONS CAREFULLY BEFORE ATTEMPTING INSTALLATION
3. BEFORE BEGINNING WORK MAKE SURE TO SET PARKING BRAKE AND CHOCK WHEELS



### ASSEMBLY TOOLS NEEDED

Impact Sockets	7/16" - 1-3/8"
Wrenches	7/16" - 1-3/8"
Torque Wrench	
Rat Tail Pry Bar	
Center Punch and Hammer	
C-Clamp	
Screwdrivers	

### INSTALLATION NOTES

1. Vehicle should be parked on a level surface with a normal vehicle load on the FRONT suspension.
2. On some vehicles it may be necessary to raise or stiffen the suspension to decrease the vehicles front suspension sag with the snow plow in place.
3. Unless otherwise specified, mount all Vehicle Mount Kit Components to vehicle before tightening any hardware.
4. It is recommended that LOCTITE®, or similar thread locking product, be used on ALL mounting hardware (i.e. Nuts, Cap Screws, Bolts, etc.).
5. Items in parentheses ( ) refer to quantity required for this step. Items in parentheses with a pound sign (#) indicate the part number as found in the parts list on the last page of this document.  
Example: (2) 1/2" Lock Washers (#9).

### MOUNTING INSTRUCTIONS

1. Remove four screws from the front of the grill.  
Remove grill.

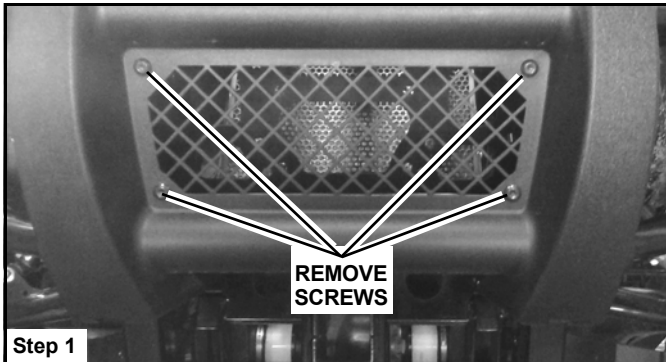

2. Remove four screws from the front of the bottom skid plate.

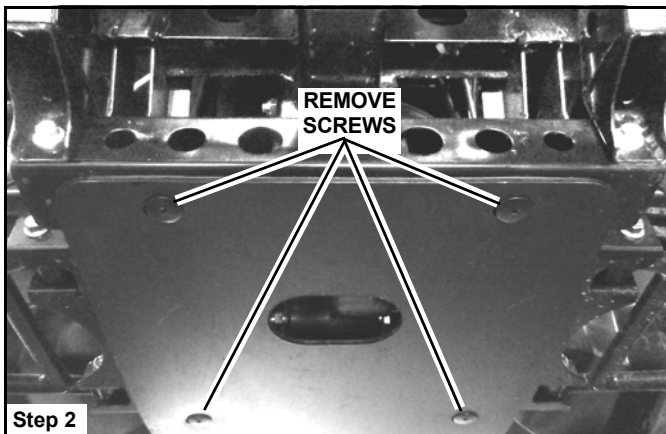

3. Remove 2 lower bumper/brush guard bolts.

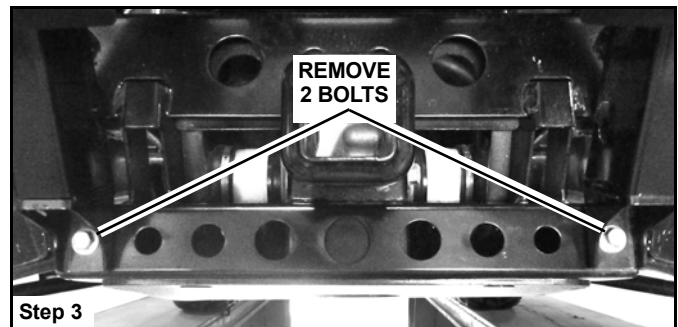

4. Insert the Rear Bracket (#1) between the frame and bumper/brush guard. Secure with (2) 7/16" x 1-1/2" Hex Head Cap Screws (#15) and (2) 7/16 Lock Nuts (#16) (Passenger side shown). Tighten.

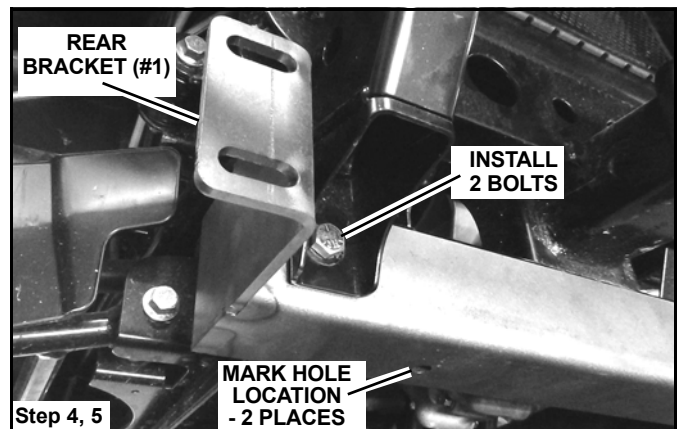

5. Mark the location of two inside holes on the bottom of the Rear Bracket (#1) onto the frame of the vehicle (Passenger side shown). Remove the Rear Bracket (#1).

6. Drill two 13/32" holes in the bottom of the vehicle frame in the marked locations. If a 13/32" drill is not available use a 7/16".
7. Re-install Rear Bracket (#1) between the frame and bumper/brush guard. Insert (2) 7/16" x 1-1/2 Hex Head Cap Screws (#15) into the bumper brush guard, thru the Rear Bracket (#1) and vehicle frame. Loosely secure with (2) 7/16" Lock Nuts (#16).
8. Insert (2) 3/8" X 1-1/4" Hex Head Cap Screws (#7) into the bottom inside holes of the Rear Bracket (#1). Loosely secure with (2) 3/8" Lock Nuts (#8).
9. Tighten all hardware installed in steps 7 and 8.
10. Drill 2 holes in the bottom skid plate to clear the heads of the (2) 3/8" x 1-1/4" Hex Head Cap Screws (#7) installed in step 8.

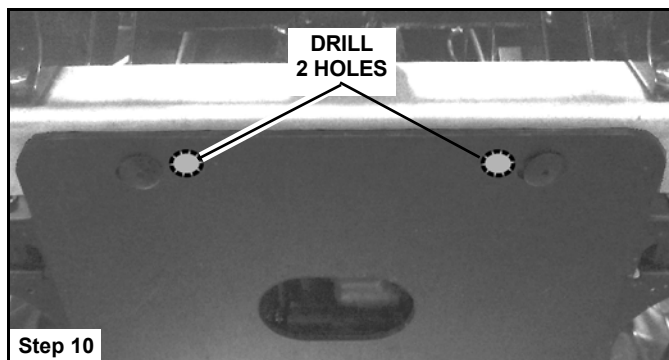

11. Replace the 4 screws in the bottom skid plate and tighten.
12. Remove 2 driver's side brush guard bolts. Place the Drivers Side Bracket (#2) against the brush guard. Insert (2) 5/16" X 3" Hex Head Cap Screws (#12) thru the Drivers Side Bracket (#2) and brush guard. Secure with (2) 5/16" Plain Washers (#14) and (2) 5/16" Lock Nuts (#13).

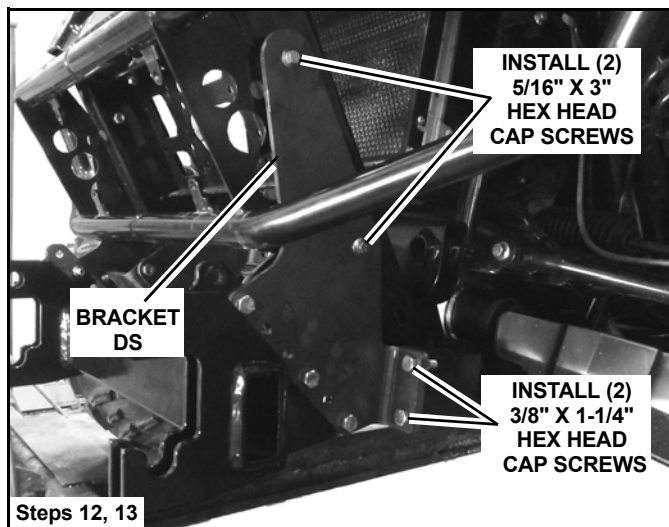

13. Insert (2) 3/8" x 1-1/4" Hex Head Cap Screws (#7) thru the two outside holes in the Drivers Side Bracket (#2) and into the rear bracket. Secure with (2) 3/8" Plain Washers (#9) and (2) 3/8" Lock Nuts (#8).
14. Repeat steps 12 and 13 to install the Passengers Side Bracket (#3) to the vehicle.

15. Align the two holes in the side of the Inside Drivers Side Bracket (#4) with the inside holes of the Drivers Side Bracket (#2). Install (2) 3/8" X 1-1/4" Hex Head Cap Screws (#7) and secure with (2) 3/8" Lock Nuts (#8).

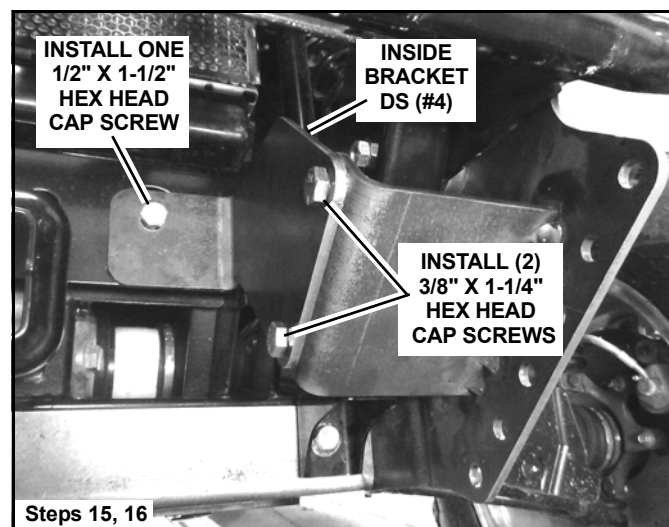

16. Place the Backing Plate (#6) behind the frame of the vehicle and align the hole with the rear hole of the Inside Drivers Side Bracket (#4). Insert (1) 1/2" x 1-1/2" Hex Head Cap Screw (#10) and secure with a (1) 1/2" Lock Nut (#11).
17. Repeat Steps 15 and 16 to install the Inside Passengers Side Bracket (#5) to the vehicle.

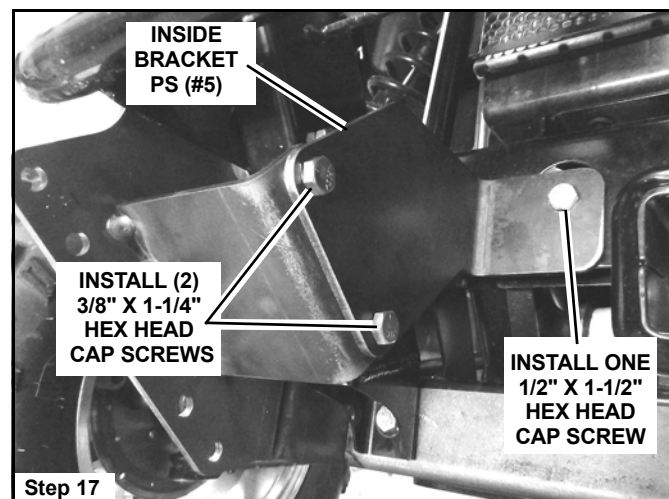

18. Position the UTV Mount (#17) to the inside of the driver and passenger Side Brackets (#2, #3). Adjust the UTV Mount height between the Side Brackets so that the center of the lower pin slots is 11 to 12 inches off the ground.

*NOTE: The UTV Mount is shipped in power pack carton.*

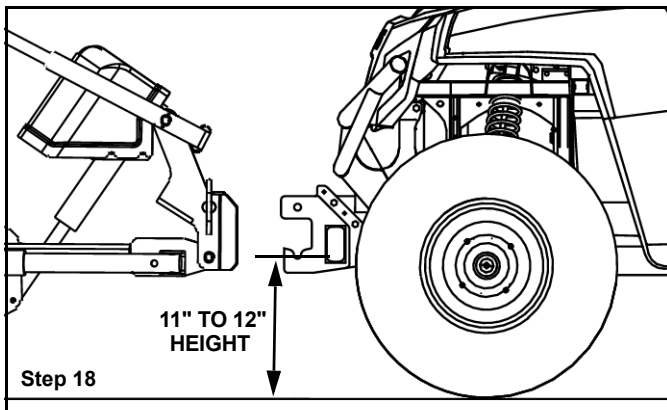
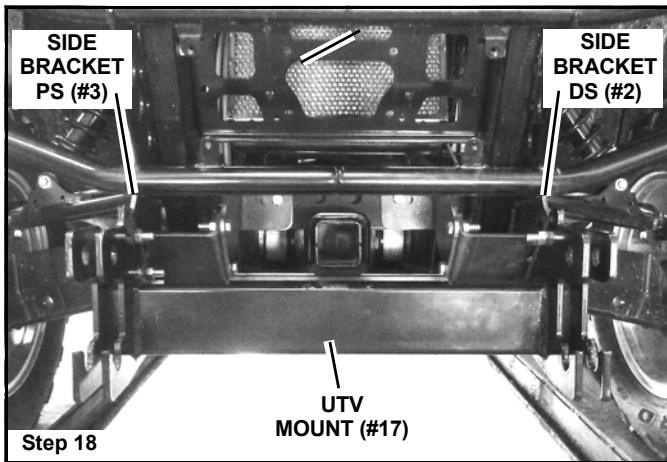

**IMPORTANT:** Height from the bottom of the lower pin slots on the UTV Mount to the ground should be between 11" and 12" to ensure proper operation.

19. Secure the UTV mount with (6) 3/8" x 1-1/4" Hex Head Cap Screws (#7) and (6) 3/8" Lock Nuts (#8).

20. Torque all hardware using the Torque Specification Chart below:

TORQUE SPECIFICATIONS FOR STANDARD MACHINE HARDWARE					
Bolt Size	GR.2 Dry	GR.5 Dry	GR.8 Dry	Metric Size	GR.8.8 Dry
1/4"	66*	9	12	M8	17
5/16"	11	17	25	M10	35
3/8"	20	30	45	M12	60
7/16"	32	50	70	M14	95
1/2"	50	75	110	M16	155
9/16"	70	110	150		
5/8"	100	150	220		
3/4"	175	260	380		
7/8"	170	430	600		
1"	250	640	900		

These torque values are to be used for all hardware. Unless otherwise specified, all torque values must meet this specification.  
All torque values are in Ft.-Lbs unless otherwise stated  
\*In-Lbs

**REMEMBER** After 5 to 10 hours of snowplow usage, re-torque all hardware!

21. Trim grill to fit around mount brackets. Re-install grill. Save all removed hardware for re-use if mount is removed from vehicle.

# PARTS LIST

Note: It is recommended that LOCTITE®, or similar thread locking product, be used on ALL mounting hardware (i.e. Nuts, Cap Screws, Bolts, etc.).

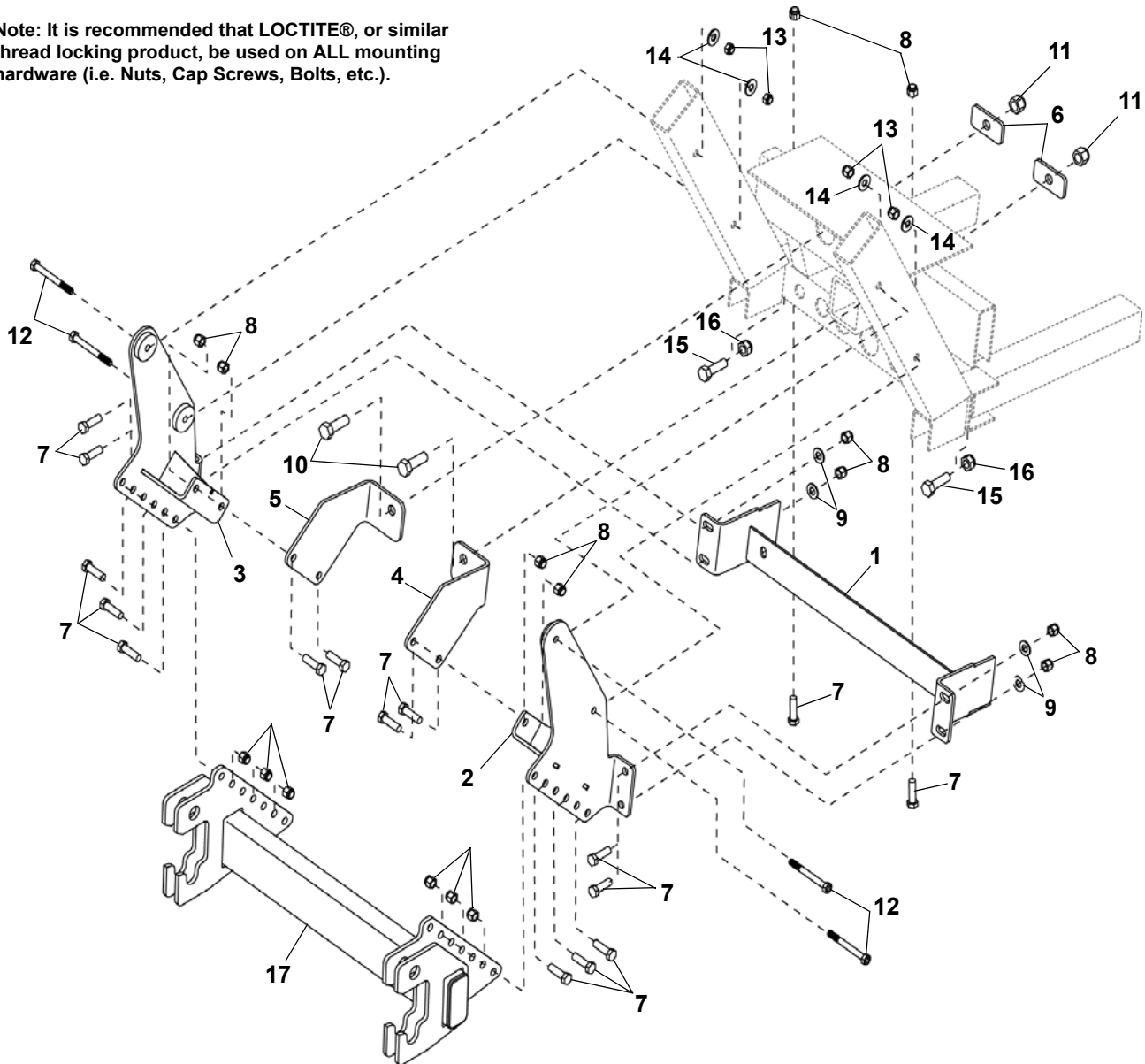

ITEM	PART NO.	DESCRIPTION	QTY.
1		Weldment, Bracket, Rear.....	1
2		Weldment, Bracket, DS .....	1
3		Weldment, Bracket, PS.....	1
4		Bracket, Inside, DS .....	1
5		Bracket, Inside, PS .....	1
6		Plate, Backing.....	2
7		HHCS, 3/8"-16 x 1-1/4" .....	16
8		LN, 3/8"-16.....	16
9		PW, 3/8".....	4
10		HHCS, 1/2"-13 x 1-1/2" .....	2
11		LN, 1/2"-13.....	2
12		HHCS, 5/16"-18 x 3" .....	4
13		LN, 5/16"-18.....	4
14		PW, 5/16".....	4
15		HHCS, 7/16"-14 x 1-1/2" .....	2
16		HNLN, 7/16"-14.....	2
17	96114780	Vehicle Center Member, UTV (Not Included).....	1
18	96115558	Kit, HDWE (Not Shown) (Includes Items 7-16).....	1

# NOTES

# NOTES

---

**SNO-WAY® INTERNATIONAL, INC.**



Hartford, WI 53027 USA  
Website: [www.snoway.com](http://www.snoway.com)  
©2024 Sno-Way® International