

# **SNO-WAY**®

**SNOW & ICE CONTROL EQUIPMENT**

## **ASSEMBLY & INSTALLATION INSTRUCTIONS**

**VEHICLE MOUNT KIT 99101276  
AND  
VEHICLE CENTER MOUNT 96114780**

TO FIT  
2016 & Later - Polaris General  
2016 - 2020 Polaris RZR 900, 1000



©2024 Sno-Way® International

97102038B



1. THINK SAFETY, ALWAYS WEAR SAFETY GLASSES WHEN PERFORMING THE OPERATIONS PRESCRIBED IN THESE INSTRUCTIONS
2. READ ALL INSTRUCTIONS CAREFULLY BEFORE ATTEMPTING INSTALLATION
3. BEFORE BEGINNING WORK MAKE SURE TO SET PARKING BRAKE AND CHOCK



## ASSEMBLY TOOLS

Impact Sockets	7/16" - 1-3/8"
Wrenches	7/16" - 1-3/8"
Torque Wrench	

## INSTALLATION NOTES

1. Vehicle should be parked on a level surface with a normal vehicle load on the FRONT suspension.
2. On some vehicles it may be necessary to raise or stiffen the suspension to decrease the vehicles front suspension sag with the snow plow in place.
3. Unless otherwise specified, mount all Vehicle Mount Kit Components to vehicle before tightening any hardware.
4. It is recommended that LOCTITE®, or similar thread locking product, be used on ALL mounting hardware (i.e. Nuts, Cap Screws, Bolts, etc.).
5. Items in parentheses () refer to quantity required for this step. Items in parentheses with a pound sign (#) indicate the part number as found in the parts list on the last page of this document.  
Example: (2) 1/2" Lock Washers (#9).

## MOUNTING INSTRUCTIONS

*NOTE: This mount will not fit if the unit is equipped with a winch or brush guard. The brush guard and fairlead for the winch will need to be removed prior to installation.*

1. Remove the Cover Plate from the bumper.  
(See Figure 1.)

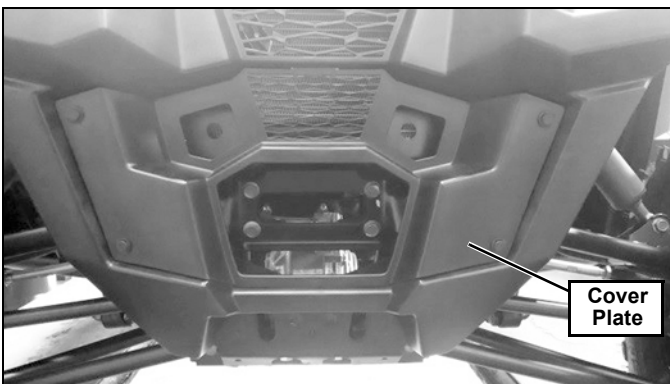

Figure 1

2. Grind in the shown areas until the cover can slip over the top of Mounting Weldment (#2).  
(See Figure 2 and Figure 3.)

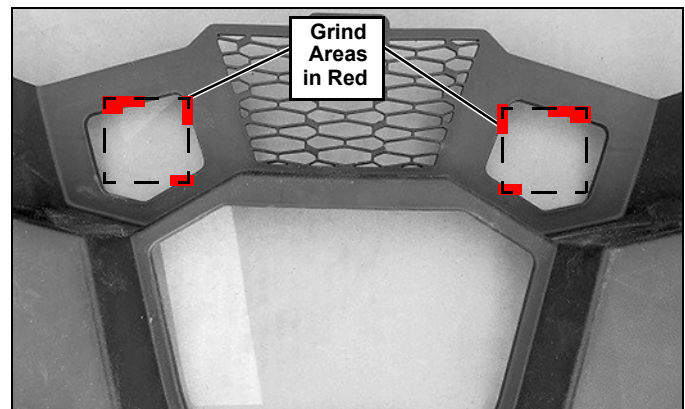

Figure 2

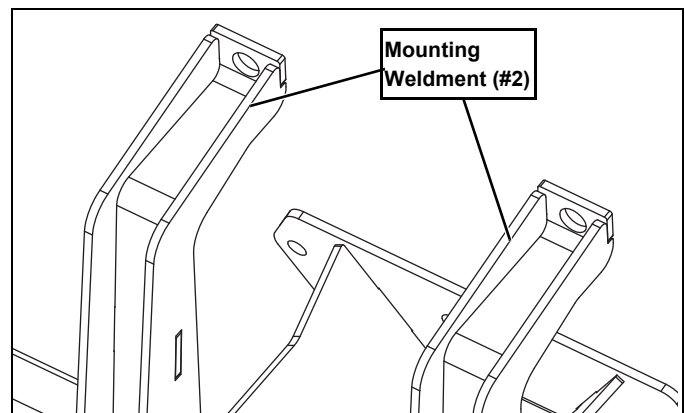

Figure 3

3. Slide the lower end of the Mounting Weldment (#2) behind the bumper and rotate until tight against the frame. Insert (2) 9/16"-12 x 1-1/2" Cap Screws (#5) into the top of item #2 and the vehicle frame. Then, secure with (2) 9/16" Plain Washers (#6) and (2) 9/16"-12 Locknuts (#7). (See Figure 4 and Figure 5.)

*NOTE: Cover plate from steps 1-2 is not shown in image below.*

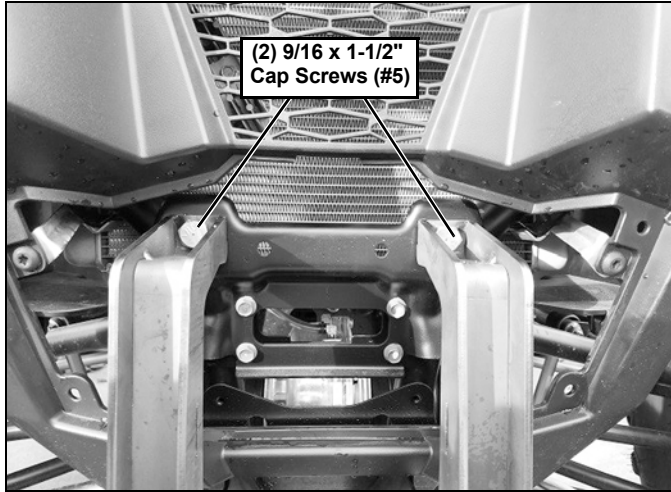

Figure 4

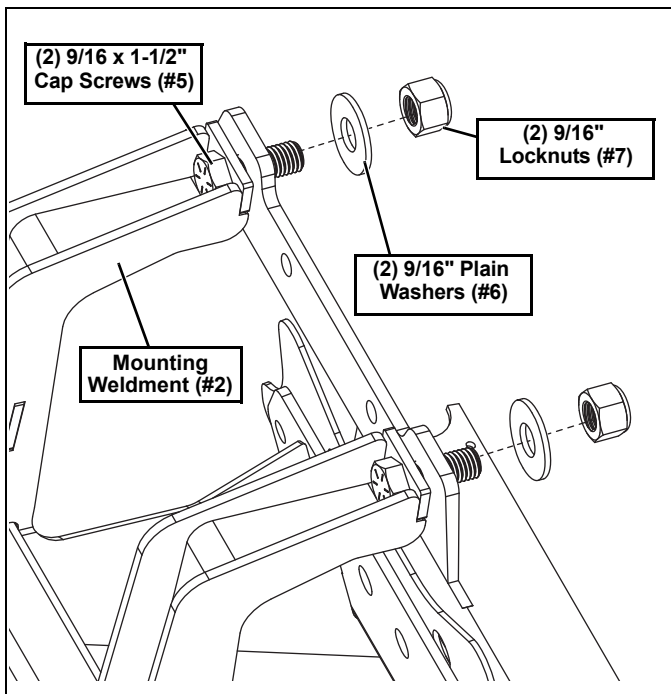

Figure 5

4. Insert (2) 1/2"-13 x 1-1/4" Caps Screws (#9) and (2) 3/8"-16 x 1" Cap Screws (#4) into the lower end of the Mounting Weldment (#2) and vehicle frame. Then, Secure with (2) 1/2"-13 Locknuts (#8) and (2) 3/8"-Locknuts (#3). (See Figure 6.)

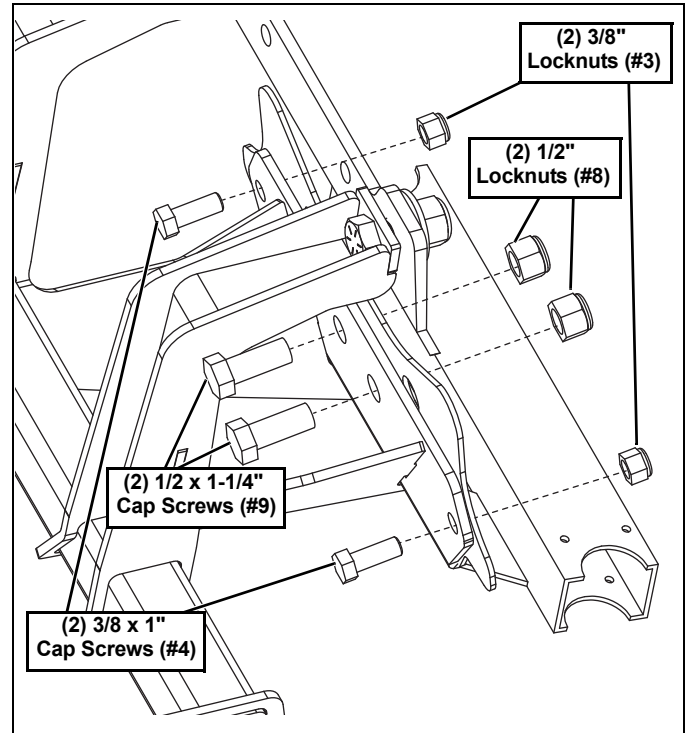

Figure 6

5. Align the UTV Mount (#1) with the holes in the Mounting Weldment (#2). Adjust the UTV Mount (#1) so that the center of the bottom slot is 11-12" off of the ground. (See Figure 7.)

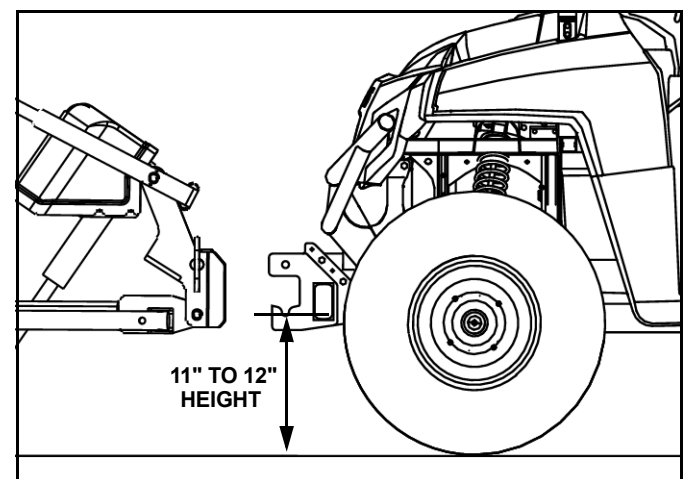

Figure 7

6. Attach the UTV Mount (#1) to the Mounting Weldment (#2) with (6) 3/8"-16 x 1" Cap Screws (#4) and (6) 3/8"-16 Locknuts (#3). Three on each side. (See Figure 8.)

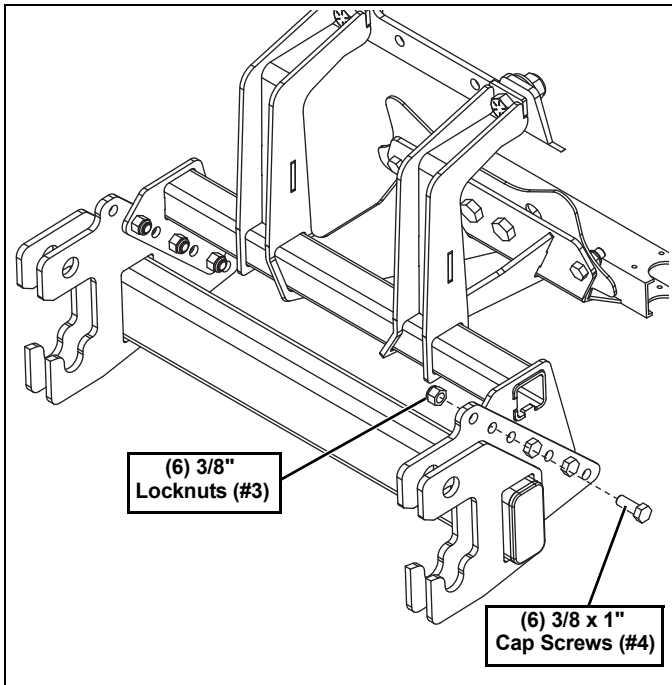

Figure 8

7. Tighten all the hardware using the Torque Specification Chart below.

TORQUE SPECIFICATIONS FOR STANDARD MACHINE HARDWARE					
Bolt Size	GR.2 Dry	GR.5 Dry	GR.8 Dry	Metric Size	GR.8.8 Dry
1/4"	66*	9	12	M8	17
5/16"	11	17	25	M10	35
3/8"	20	30	45	M12	60
7/16"	32	50	70	M14	95
1/2"	50	75	110	M16	155
9/16"	70	110	150		
5/8"	100	150	220		
3/4"	175	260	380		
7/8"	170	430	600		
1"	250	640	900		

These torque values are to be used for all hardware. Unless otherwise specified, all torque values must meet this specification. All torque values are in Ft.-Lbs unless otherwise stated  
\*In-Lbs

**REMEMBER After 5 to 10 hours of snowplow usage, re-torque all hardware!**

# PARTS LIST

Note: It is recommended that LOCTITE®, or similar thread locking product, be used on ALL mounting hardware (i.e. Nuts, Cap Screws, Bolts, etc.).

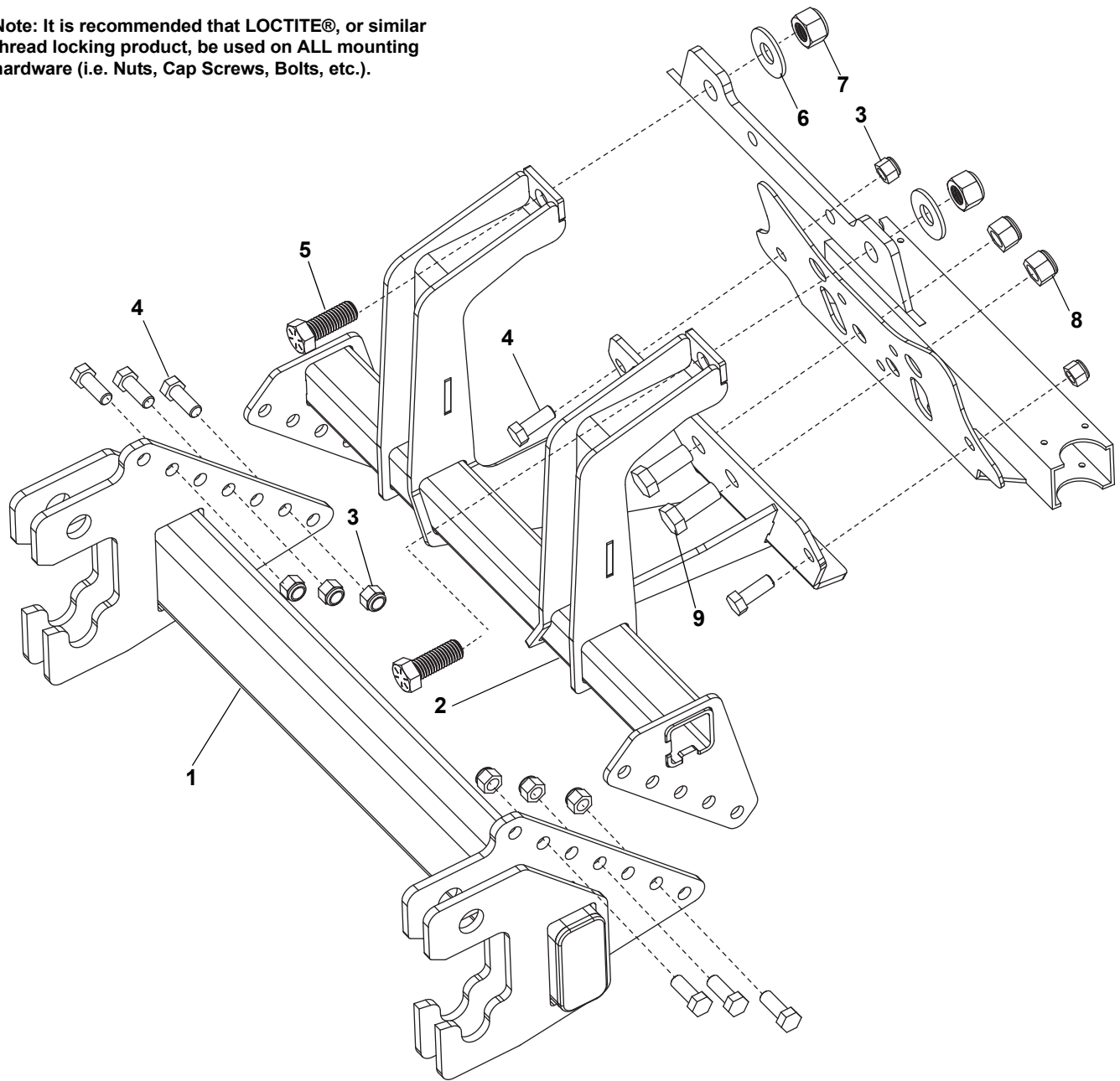

ITEM	PART NO.	DESCRIPTION	QTY.
1	96114780	Vehicle Center Member, UTV (Not Included).....	1
2		Weldment, Mounting.....	1
3		LN, 3/8"-16.....	8
4		HHCS, 3/8"-16 x 1".....	8
5		HHCS, 9/16"-12 x 1-1/2".....	2
6		PW, 9/16".....	2
7		LN, 9/16"-12.....	2
8		LN, 1/2"-13.....	2
9		HHCS, 1/2"-13 x 1-1/4".....	2
10	96116375	Kit, HDWE (Not Shown) (Includes Items 3-9).....	1

# NOTES

# NOTES

---

**SNO-WAY® INTERNATIONAL, INC.**



Hartford, WI 53027 USA  
Website: [www.snoway.com](http://www.snoway.com)  
©2024 Sno-Way® International