

SNO-WAY®

SNOW & ICE CONTROL EQUIPMENT

ASSEMBLY & INSTALLATION INSTRUCTIONS

**VEHICLE MOUNT KIT 99101279
AND
VEHICLE CENTER MOUNT 96114780**

TO FIT
2008 - 2022 Kubota RTV 400, 500
2021 & Later - Kubota RTV 520



©2024 Sno-Way® International

97102050B



1. THINK SAFETY, ALWAYS WEAR SAFETY GLASSES WHEN PERFORMING THE OPERATIONS PRESCRIBED IN THESE INSTRUCTIONS
2. READ ALL INSTRUCTIONS CAREFULLY BEFORE ATTEMPTING INSTALLATION
3. BEFORE BEGINNING WORK MAKE SURE TO SET PARKING BRAKE AND CHOCK WHEELS



ASSEMBLY TOOLS NEEDED

Drill Bits	1/4" - 5/8"
Impact Sockets	7/16" - 3/4"
Wrenches	7/16" - 3/4"
Torque Wrench	
Rat Tail Pry Bar	
Center Punch and Hammer	
Screwdrivers	

INSTALLATION NOTES

1. Vehicle should be parked on a level surface with a normal vehicle load on the FRONT suspension.
2. On some vehicles it may be necessary to raise or stiffen the suspension to decrease the vehicles front suspension sag with the snow plow in place.
3. Unless otherwise specified, mount all Vehicle Mount Kit Components to vehicle before tightening any hardware.
4. It is recommended that LOCTITE®, or similar thread locking product, be used on ALL mounting hardware (i.e. Nuts, Cap Screws, Bolts, etc.).
5. Items in parentheses () refer to quantity required for this step. Items in parentheses with a pound sign (#) indicate the part number as found in the parts list on the last page of this document.
Example: (2) 1/2" Lock Washers (#9).

MOUNTING INSTRUCTIONS

1. Remove the two carriage bolts holding the cover to the top of the frame just behind the bumper.
(See Figure 1.)

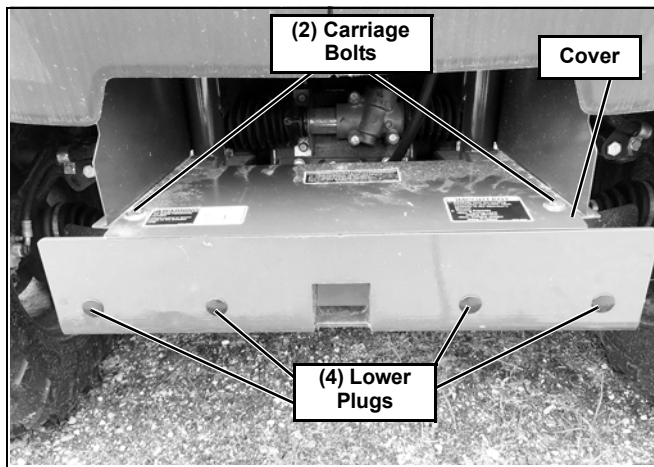

Figure 1

2. Remove four lower bumper/brush guard plugs.
3. Remove cover and enlarge the two top holes using a 13/32" diameter drill bit. If a 13/32" diameter drill bit is not available use a 7/16" diameter bit. Place cover back on top of frame.

4. Place the VMK Weldment (#5) tabs on top of the cover and push up against the bumper. Place (2) 3/8" x 1-1/4" Cap Screws (#2) thru the top holes of the VMK Weldment (#5) into the top cover and frame. Secure with (2) 3/8" Lock Nuts (#4). (See Figure 2.)

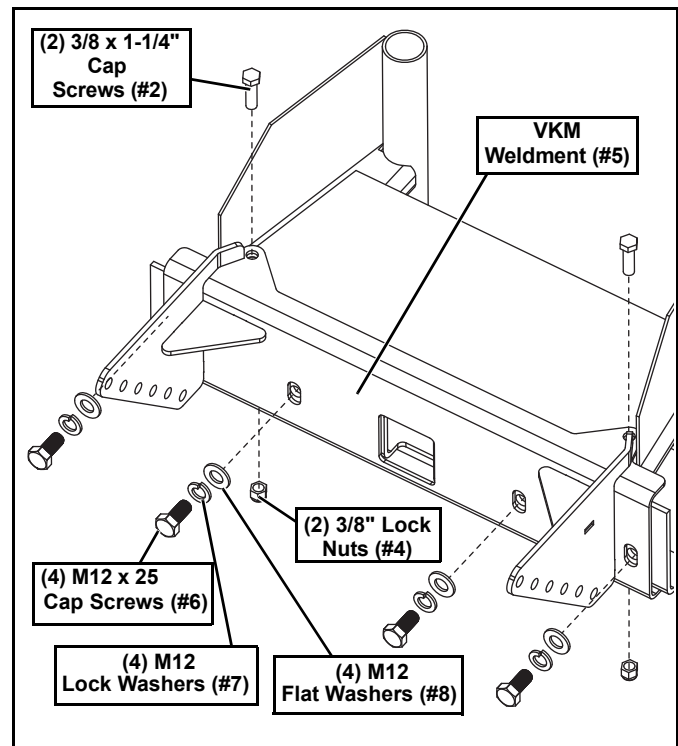

Figure 2

5. Insert (4) M12 X 25 Cap Screws (#6), (4) M12 Lock Washers (#7), and (4) M12 Flat Washers (#8) thru front holes of VMK Weldment (#5) and into bumper.
(See Figure 2.)

6. Tighten all hardware installed in steps 4-5.
7. Position the UTV Mount (#1) on the machine. Align the Mount holes with the VKM Weldment (#5) to provide an 11" to 12" height between the lower pin slots and the ground. (See Figure 3.) Place spacers (#3) between VKM Weldment (#5) and UTV Mount (#1). Secure with (6) 3/8" x 1-1/4" cap screws (#2) and (6) 3/8" lock nuts (#4). Tighten hardware. (See Figure 4.)

NOTE: The UTV Mount is shipped in power pack carton.

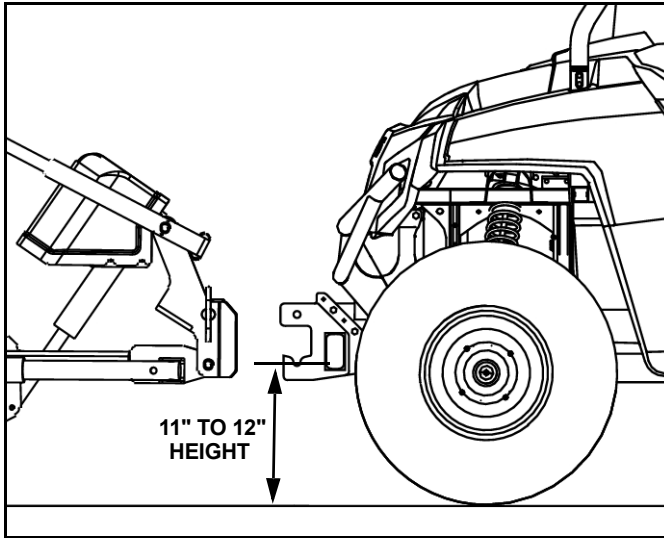

Figure 3

IMPORTANT: Height from the bottom of the lower pin slots on the UTV Mount to the ground should be between 11" and 12" to ensure proper operation.

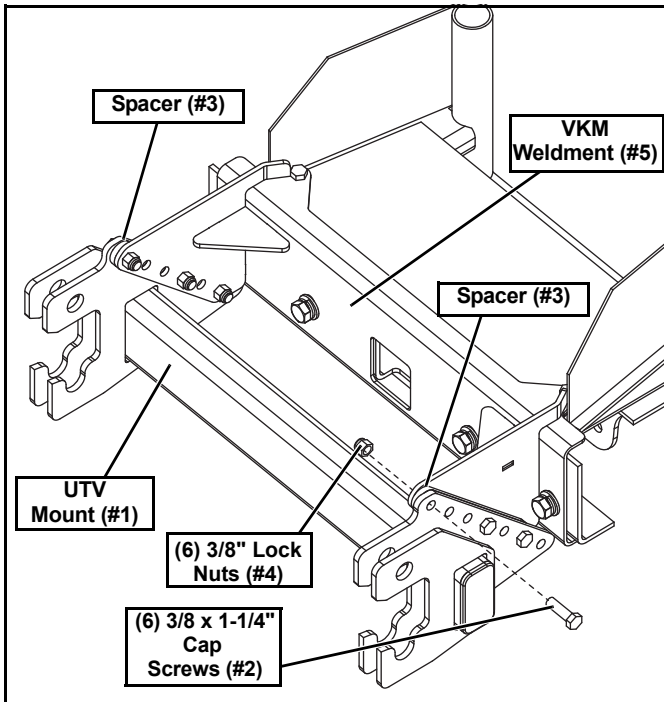

Figure 4

8. Torque all hardware using the Torque Specification Chart below:

TORQUE SPECIFICATIONS FOR STANDARD MACHINE HARDWARE					
Bolt Size	GR.2 Dry	GR.5 Dry	GR.8 Dry	Metric Size	GR.8.8 Dry
1/4"	66*	9	12	M8	17
5/16"	11	17	25	M10	35
3/8"	20	30	45	M12	60
7/16"	32	50	70	M14	95
1/2"	50	75	110	M16	155
9/16"	70	110	150		
5/8"	100	150	220		
3/4"	175	260	380		
7/8"	170	430	600		
1"	250	640	900		

These torque values are to be used for all hardware. Unless otherwise specified, all torque values must meet this specification.
All torque values are in Ft.-Lbs unless otherwise stated
*In-Lbs

REMEMBER After 5 to 10 hours of snowplow usage, re-torque all hardware!

PARTS LIST

Note: It is recommended that LOCTITE®, or similar thread locking product, be used on ALL mounting hardware (i.e. Nuts, Cap Screws, Bolts, etc.).

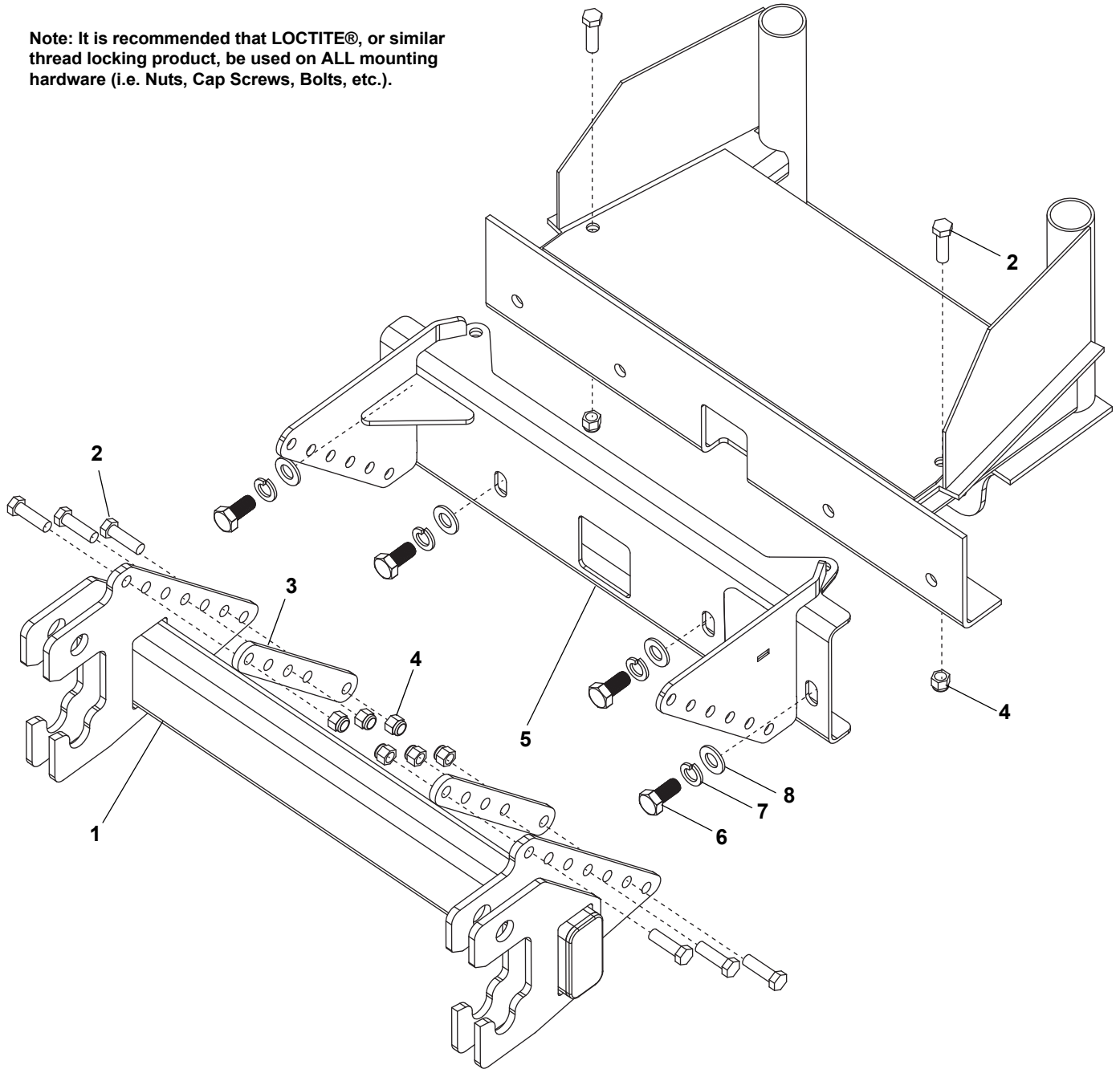

ITEM	PART NO.	DESCRIPTION	QTY.
1	96114780	Vehicle Center Member, UTV (Not Included).....	1
2		HHCS, 3/8" x 1-1/4"	8
3		Spacer.....	2
4		HN, 3/8"-16	8
5		VKM Weldment.....	1
6		HHCS, M12x25.....	4
7		LW, M12.....	4
8		PW, M12	4
9	96116532	Kit, HDWE (Not Shown) (Includes Items 2, 4, 6, 7 and 8)	1

SNO-WAY® INTERNATIONAL, INC.



Hartford, WI 53027 USA
 Website: www.snoway.com
 ©2024 Sno-Way® International