

SNO-WAY®

SNOW & ICE CONTROL EQUIPMENT

ASSEMBLY & INSTALLATION INSTRUCTIONS

**VEHICLE MOUNT KIT 99101386
AND
VEHICLE CENTER MEMBER 99100891**

**TO FIT
2019 & LATER DODGE RAM 4500/5500 4X2 & 4X4**

Sno-Way®, Down Pressure® and EIS® are registered trademarks of Sno-Way International, Inc.
ProControl™, MegaBlade™, V-Wing™, E-Z Switch™, Revolution™, MaxAdjust™, SpeedLock™, and QuickJack™
are trademarks of Sno-Way International, Inc.

©2019 Sno-Way® International

97102188A



1. THINK SAFETY, ALWAYS WEAR SAFETY GLASSES WHEN PERFORMING THE OPERATIONS PRESCRIBED IN THESE INSTRUCTIONS
2. READ ALL INSTRUCTIONS CAREFULLY BEFORE ATTEMPTING INSTALLATION
3. BEFORE BEGINNING WORK MAKE SURE TO SET PARKING BRAKE AND CHOCK WHEELS



MINIMUM VEHICLE RECOMMENDATIONS

Heavy Duty Alternator
 Heavy Duty Battery
 Manufacturers Snow Plow Package

NOTE: On some vehicles it may be necessary to use a form of load booster to decrease the vehicle's front suspension sag with the snow plow in place. This can be accomplished with the use of supplementary air bags, booster springs, or similar load boosting devices. Since there are different load boosting devices available, it will up to the customer/end user to decide and purchase the product to suit the application, and not the responsibility of Sno-Way International, Inc.

ASSEMBLY TOOLS NEEDED

Drill Bits	1/4" and 21/32"
Impact Sockets	7/16" – 1-3/8"
Impact Sockets, Metric	10mm – 18mm
Wrenches	7/16" – 1-3/8"
Wrenches, Metric	10mm - 18mm
Torque Wrench	
Center Punch and Hammer	
Rat Tail Pry Bar	

INSTALLATION NOTES

1. Unless otherwise specified, mount all Subframe Components to vehicle before tightening any hardware.
2. It is recommended that LOCTITE®, or similar thread locking product, be used on ALL mounting hardware (i.e. Nuts, Cap Screws, Bolts, etc.).
3. Vehicle should be parked on a level surface with a normal vehicle load on the FRONT suspension.
4. Items in parentheses () refer to quantity required for this step. Items in parentheses with a pound sign (#) indicate the part number as found in the parts list on the last page of this document.
 Example: (2) 5/8" - 11 x 2" Cap Screws (#10).
5. It may be necessary to relocate license plate holder. Check state and local laws for placement, if applicable.

2. Remove the lower valance or modify it to slide the Driver Side Mounting Weldment (#2) up onto the frame rail.
3. Modification by cutting the bumper bracket will be needed to fit the Mounting Weldments (#2 & 3). Cut away the bumper bracket where it interferes. (See Figure 2.) Use touch up paint to protect the exposed steel.

MOUNTING INSTRUCTIONS

1. Remove the lower front bolts in the driver and passenger side frame rail. (See Figure 1.)

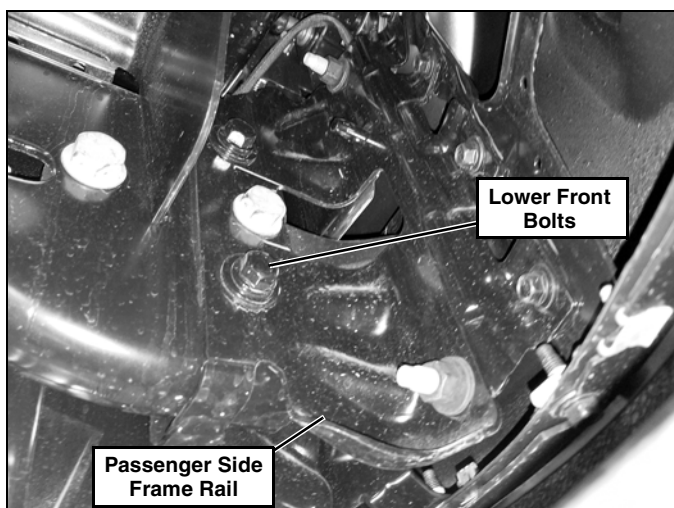

Figure 1

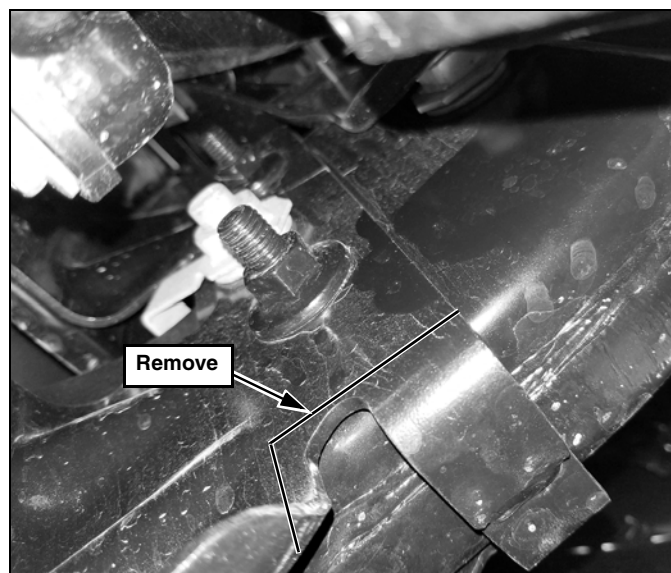

Figure 2

4. Once one side fits up with the two front holes lined up, repeat to the opposite side frame rail.

5. Align the Driver Side Mounting Weldment (#2) up to the frame and over the bumper bracket. Secure with (1) 1/2"-13 x 4" Cap Screw (#7), (1) 1/2"-13 Locknut (#9), (1) 5/8"-11 x 4-1/2" Cap Screw (#8), and (1) 5/8"-11 Locknut (#10). (See Figure 3.)

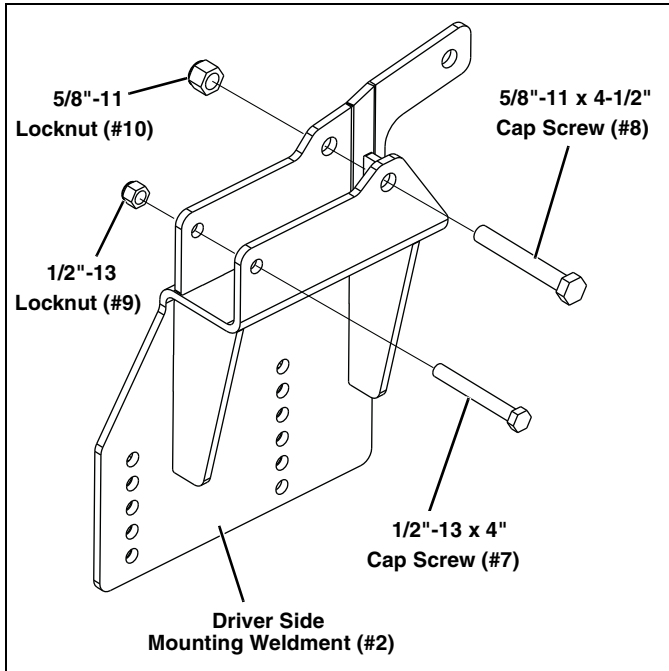

Figure 3

6. Use the rearmost hole in the Driver Side Mounting Weldment (#2) as a template. Mark, center punch, and drill a hole to 21/32". Slide a 5/8"-11 x 1-1/2" Handle Bolt Weldment (#11) into the frame and drilled hole. Secure with a 5/8"-11 Locknut (#10). (See Figure 4.)

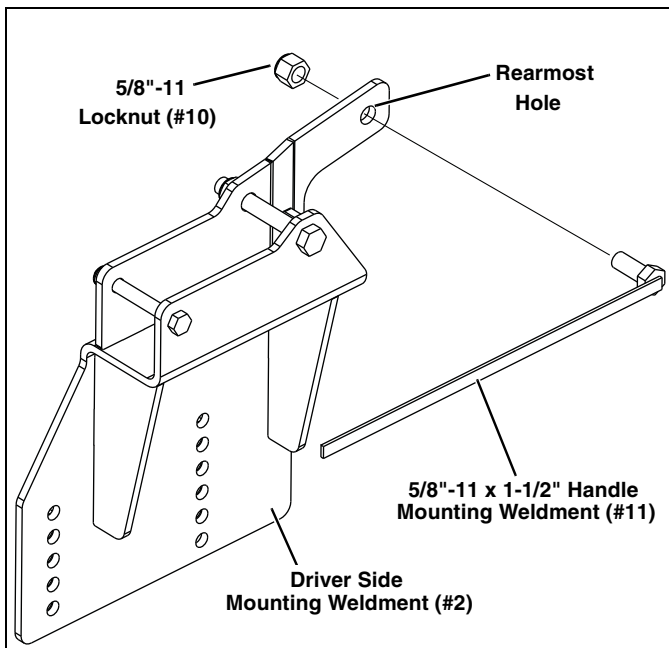

Figure 4

7. Repeat steps 5 & 6 for installing the Passenger Side Mounting Weldment (#3).

8. Install (1) Vehicle Center Member (#1) between the Side Weldments (#2 & #3) using (4) 1/2" Spacers (#4), (8) 1/2"-13 x 2" Cap Screws (#6), (2) 1/2" Lock Washers (#5) on Cap Screws used in the threaded holes, and (6) 1/2"-13 Locknuts (#9). (See Figure 5.)

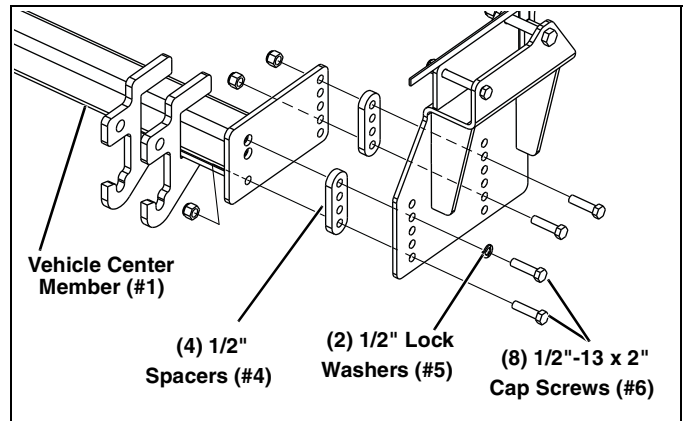
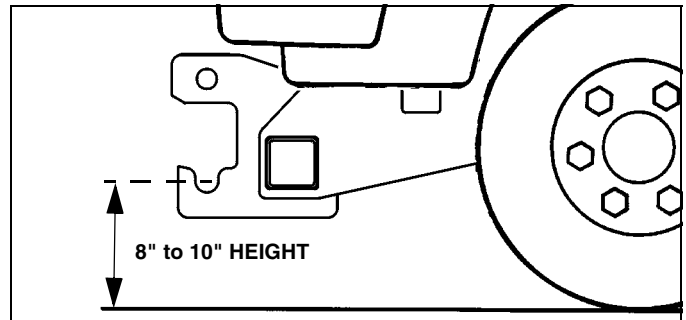

Figure 5

9. With all components in place, tighten all hardware. The mounting hardware for the VCM should be tightened first, followed by the Side weldment hardware.



IMPORTANT: Height from the bottom of the lower pin slots on the Vehicle Center Member (VCM) to the ground should be between 8" and 10" to ensure proper operation.

10. Using the Torque Specification chart provided, torque all cap screws.

TORQUE SPECIFICATIONS FOR STANDARD MACHINE HARDWARE					
Bolt Size	GR.2 Dry	GR.5 Dry	GR.8 Dry	Metric Size	GR.8.8 Dry
1/4"	66*	9	12	M8	17
3/8"	20	30	45	M12	60
1/2"	50	75	110	M16	155
5/8"	100	150	220		
7/8"	170	430	600		

Note: These torque values are to be used for all hardware. Unless otherwise specified, all torque values must meet this specification.
 Note: All torque values are in Ft.-Lbs unless otherwise stated
 Note: *In-Lbs

REMEMBER After 5 to 10 hours of snowplow usage, re-torque all Cap Screws!

PARTS LIST

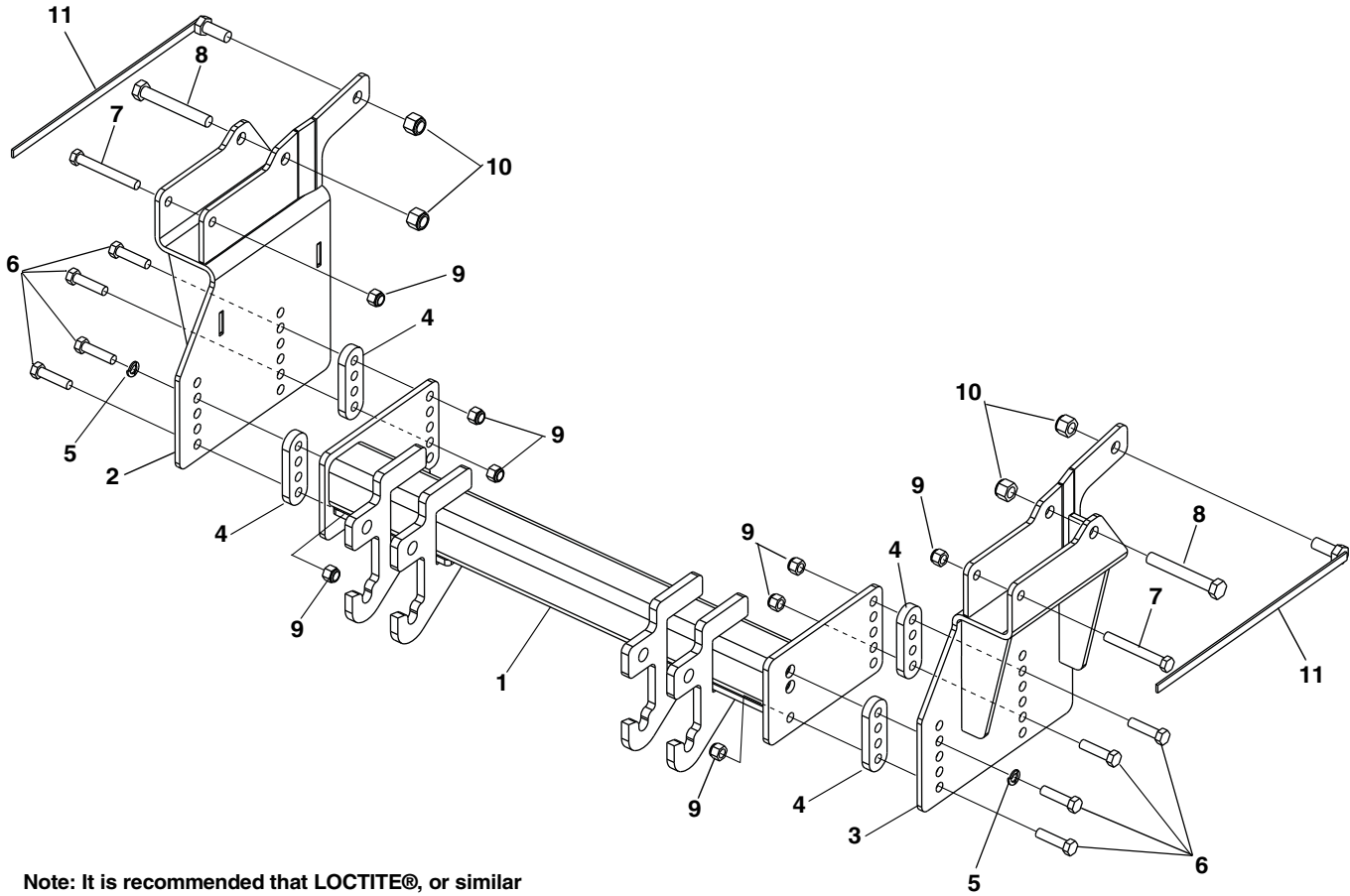

Note: It is recommended that LOCTITE®, or similar thread locking product, be used on ALL mounting hardware (i.e. Nuts, Cap Screws, Bolts, etc.).

ITEM	PART NO.	DESCRIPTION	QTY.
1		Center Member.....	1
2		Side Weldment, PS	1
3		Side Weldment, DS	1
4		Spacer, 1/2"	4
5		LW, 1/2"	2
6		HHCS, 1/2"-13 x 2", GR 8	8
7		HHCS, 1/2"-13 x 4", GR 8	2
8		HHCS, 5/8"-11 x 4-1/2", GR 8	2
9		LN, 1/2"-13, Nylock.....	8
10		LN, 5/8"-11, Nylock.....	4
11		Handle Bolt, 5/8"-11 x 1-1/2"	2
12	96117427	Kit, Hardware (Includes Items 4-11) (Not Shown)	1

SNO-WAY® INTERNATIONAL, INC.



Hartford, WI 53027 USA
 Website: www.snoway.com
 ©2019 Sno-Way® International